

### PDN 3672A Double Pressure Cabinet for Non-aggressive Media\*



**High  
Performance  
Dry Stripping**



Model PRH 3672A, 2 cu ft blast machine, and RPH dust collector

**For dry stripping with plastic or other non-aggressive recyclable media\*, pressure blasting delivers the velocity for the impact intensity needed to clean parts without damaging the surface. Available in standard and ergonomic sit-down styles.**

#### Common Applications

- General cleaning of light metals, fiberglass, stainless steel, glass, aluminum and composites
- Deflashing plastic parts
- Paint stripping of powder coated parts, ink wells, golf balls, paint guns, racks, hooks, vehicles, ground support equipment, aircraft
- Cleaning and stripping of molds, tooling, automotive and aircraft engine components, wheels, turbines, semi-conductors, silk screen frames
- Special finishes for sculpture and artwork

\*This cabinet is not designed for use with soda media. Bicarbonate of soda, a non-aggressive, single-use media, requires unique equipment considerations. Several Aerolyte cabinet models are available for light-duty or high-production soda blasting. Consult your local authorized Clemco distributor.

#### The Aerolyte Cabinet Features:

##### Safety

- ✓ Full-length, neoprene-on-fabric gloves resist wear and protect operator.
- ✓ Ceiling-mounted, two-tube fluorescent light fixture with abrasive resistant cover for extraordinary visibility.
- ✓ Safety interlocks interrupt blasting if door is opened.
- ✓ Pressure relief valve, set at 65 psi, automatically opens to signal higher pressure blasting to prevent surface damage.

##### Productivity

- ✓ Two stations for one blast operator provide easy access to blast from either station to accommodate large or complex parts. One nozzle and foot pedal are standard. For a cabinet equipped for two operators contact your local distributor.
- ✓ High-efficiency, 2.0 cubic foot capacity, epoxy-lined pressure vessel with 60° conical bottom, fitted with 1" ID piping, 3/4" ID x 16 ft coupled blast hose, and integrated controls.
- ✓ Adjustable vortex on reclaimer prevents reusable media carryover to dust collector.
- ✓ Unique air logic system (pilot actuated) to maximize air flow to the nozzle.
- ✓ Double-wall, sound-insulated doors on both sides.
- ✓ 14-gauge steel all-welded construction, with strength breaks to form a rigid, long-lasting cabinet shell.
- ✓ Two 12.5" x 19.5" windows.

##### Convenience

- ✓ Tilt-out windows, for tool-free glass changes in minutes.
- ✓ Pressure regulator, gauge, and electric switch mounted within easy reach.
- ✓ Built-in air blow-off aids monitoring part cleaning progress and removes excess media.

#### Tungsten Carbide Blast Nozzle

The TYP-5 (5/16-inch orifice) tungsten carbide nozzle is ideal for most blasting jobs.

#### Popular Options

- Additional door set
- Additional operator station
- Air-powered vertical lift door
- Anti-fatigue mat
- Armrest assembly
- HEPA filter
- Magnetic reclaimer screen
- Manometer kit
- Noise-reduction arm port baffles
- Oscillator assembly
- Timed door release
- 20" dia. turntable, 25 lb capacity
- 20" turntable (500 lb capacity) with 8 ft track extension

Authorized Distributor:



**Fortune Metal Finishing Corp.**  
116 Gould Street  
Needham Heights, MA 02494  
866.449.4160  
sales@fortunemetal.com

# S P E C I F I C A T I O N S

## COMPLETE SYSTEM

Space required depends on configurations, options and work flow. Allow space for operator and maintenance access. See maintenance access height (MAH) below.

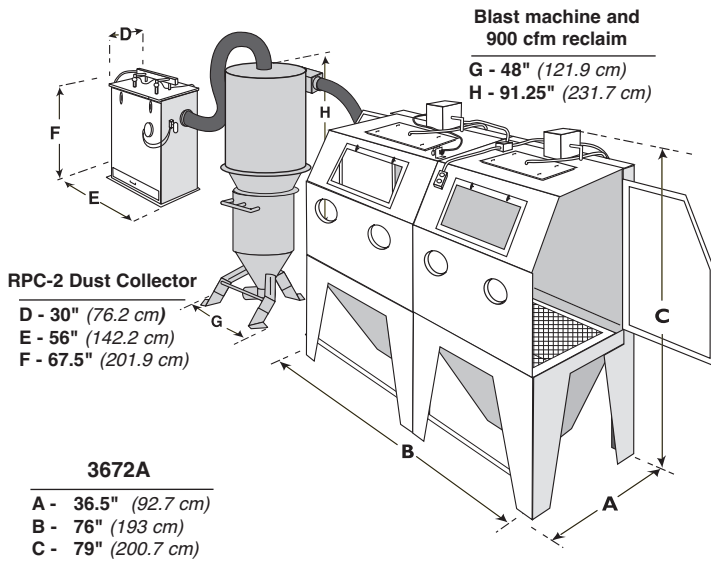

Model illustrated: PRN 3672A with RPC-2 dust collector

## CABINET

### Working Chamber Size

3672A	73" wide (1854 mm)
	35" deep (889 mm)
	37" high (940 mm)

### Window Size (safety glass)

30" wide (762 mm)  
 20" high (508 mm)

### Door Opening

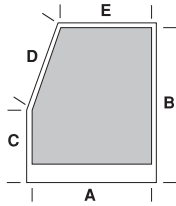

3672A

A - 32.5" (825 mm)
B - 34.5" (864 mm)
C - 19" (483 mm)
D - 17.5" (444 mm)
E - 24" (610 mm)

## DUST COLLECTORS

ZERO RP dust collectors trap 99.7% of dust particles down to 0.5 micron.

### CDC-1

CDC-1 dust collectors come in three sizes; 300 cfm, 600 cfm, and 900 cfm. The cartridges are pulse-cleaned by pressing the manual pulse-valve to clear the filter of dust. Dimensions are 34" wide, 42" deep (with motor housing) and 94" high. MAH is 11 ft for the 300 cfm and 600 cfm units and 12-1/2 ft for the 900 cfm unit.

### RPC-2

The RPC-2 has two cartridges which provide 470 sq ft of filter area. The cartridges are automatically pulse-cleaned for maximum filter efficiency. Dimensions are: 56" wide (with motor housing) by 30" deep by 67.5" high. The MAH for the RPC-2 series is 8 ft 10 inches.

### RPH-2

The RPH-2 has a filter area of 470 sq ft; the RPH-3 has a 705 sq ft filter area. Both have a built-in hopper to minimize dust-handling. At each pulse, dust falls first into the hopper and then into a disposal drum or bag beneath it. The operator never handles the dust—an important safety feature. RPH dust collector dimensions are: 56" wide (with motor housing) by 36" deep by 115" high. The RPH is designed to allow outdoor installation. The MAH for the RPH collectors is 15 ft 2 inch.

## BLAST/ RECLAIM SYSTEM

Our exclusive media reclaimers continuously extract dust and debris and return properly sized, usable media to the blast system.

The versatile design of our larger reclaimers lets you quickly adapt the system to your changing needs.

The reclaimer, mounted atop the pressure vessel, automatically refills the blast system with clean, recycled media.

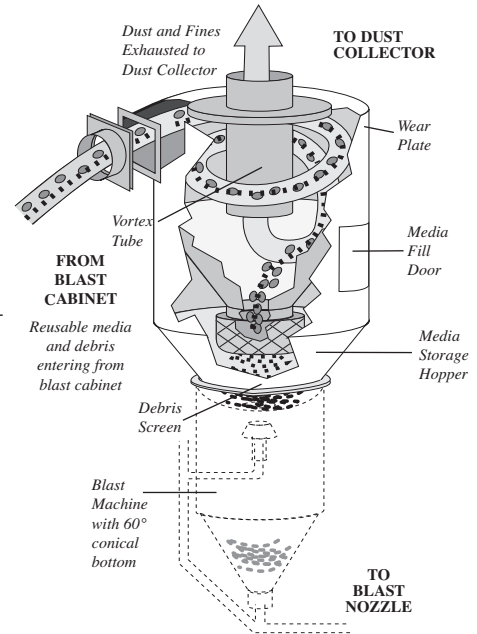

## NOZZLES

### AIR REQUIREMENTS

NOZZLE	NOZZLE ORIFICE	CFM at 50 PSI	M <sup>3</sup> /Min at 3,5 BAR
No. 5	5/16"	77	2,16*

\*3672A comes with a TYP-5 tungsten carbide nozzle.

## ELECTRICAL

900 CFM (25 m<sup>3</sup>/m) 2HP, 230/460V, 3PH, 60HZ. Other motors and electrical configurations (such as 50HZ) are available to make your system compatible with local power systems. Consult your local distributor.

## ORDERING INFORMATION

Model Number	Dust Collector	Reclaim CFM (m <sup>3</sup> /m)	Stock No.	Ship Wt. lb (kg)
PDN 3672A	CDC-1	900 (25)	28099	1,715 (778)
PRN 3672A	RPC-2	900 (25)	20157	2,100 (953)
PRH 3672A	RPH	900 (25)	24792	2,675 (1213)

Distributor:

Authorized Distributor:



**Fortune Metal Finishing Corp.**  
**116 Gould Street**  
**Needham Heights, MA 02494**  
**866.449.4160**  
**sales@fortunemetal.com**

ISO 9001 certified. Clemco is committed to continuous product improvement. Specifications are subject to change without notice.

© 2016 Clemco Industries Corp. • Washington, MO 63090 • 636 239-4300 • FAX 800 726-7559