

AEROLYTE® By Clemco Industries Corp. Systems

PDN 4050 A Pressure Cabinet for Non-aggressive Media*



Model PRN 4050A, 2 cu ft blast machine with 60° conical bottom and RPC-2 dust collector

For dry stripping with plastic or other non-aggressive recyclable media, pressure blasting delivers the velocity for the impact intensity needed to clean parts without damaging the surface. Available in standard and ergonomic sit-down styles.*

**High
Performance
Dry Stripping**



Tungsten Carbide Blast Nozzle

The TYP-5 (5/16-inch orifice) tungsten carbide nozzle is ideal for most blasting jobs.

Common Applications

- General cleaning of light metals, fiberglass, stainless steel, glass, aluminum and composites
- Deflashing plastic parts
- Paint stripping of powder coated parts, ink wells, golf balls, paint guns, racks, hooks, vehicles, ground support equipment, aircraft
- Cleaning and stripping of molds, tooling, automotive and aircraft engine components, wheels, turbines, semi-conductors, silk screen frames
- Special finishes for sculpture and artwork

*This cabinet is not designed for use with soda media.

Bicarbonate of soda, a non-aggressive, single-use media, requires unique equipment considerations. Several Aerolyte cabinet models are available for light-duty or high-production soda blasting. Consult your local authorized Clemco distributor.

The Aerolyte Cabinet Features: Safety

- ✓ Full-length, neoprene-on-fabric gloves resist wear and protect operator.
- ✓ Ceiling-mounted, two-tube fluorescent light fixture with abrasive cover for extraordinary visibility.
- ✓ Safety interlocks interrupt blasting if door is opened.
- ✓ Pressure relief valve, set at 65 psi, automatically opens to signal higher pressure blasting to prevent surface damage.

Productivity

- ✓ High-efficiency, 2.0 cubic foot capacity, epoxy lined pressure vessel with 60° conical bottom, fitted with 1" ID piping, 3/4" ID x 16 ft coupled blast hose, and integrated controls.
- ✓ Adjustable vortex on reclaimer prevents reusable media carryover to dust collector.
- ✓ Unique air logic system (pilot actuated) to maximize air flow to the nozzle.
- ✓ Double-wall, sound-insulated doors on both sides.
- ✓ 14-gauge steel all-welded construction, with strength breaks to form a rigid, long-lasting cabinet shell.
- ✓ Large 12.5" x 19.5" view window.

Convenience

- ✓ Tilt-out window, for tool-free glass changes in minutes.
- ✓ Pressure regulator, gauge, and electric switch mounted within easy reach.
- ✓ Built-in air blow-off aids monitoring part cleaning progress and removes excess media.

Popular Options

- Air-powered vertical lift door
- Anti fatigue mat
- Armrest assembly
- HEPA filter
- Magnetic reclaimer screen
- Manometer kit
- Noise-reduction arm port baffles
- Oscillator assembly
- Storage hopper, 2 cu ft
- Timed door release
- 20" dia. turntable with or without 8 ft track extension

Authorized Distributor:



Fortune Metal Finishing Corp.
116 Gould Street
Needham Heights, MA 02494
866.449.4160
sales@fortunemetal.com

S P E C I F I C A T I O N S

COMPLETE SYSTEM

Space required depends on configurations, options and work flow. Allow space for operator and maintenance access. See maintenance access height (MAH) below.

RPC-2

- D - 30" (76.2 cm)
- E - 56" (142.2 cm)
- F - 67.5" (201.9 cm)

4050A

- A - 40" (101.6 cm)
- B - 56" (142.2 cm)
- C - 83.5" (212.1 cm)

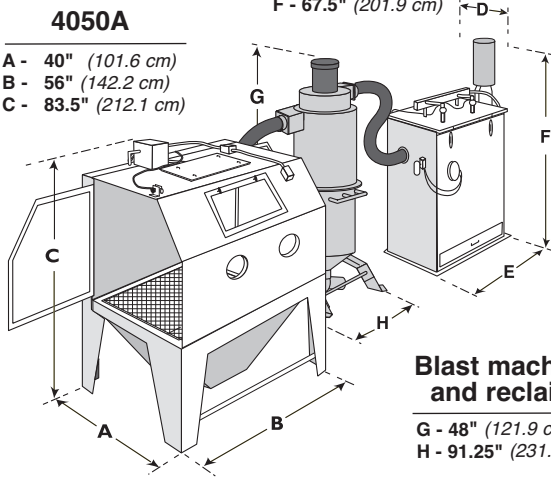

Blast machine and reclaim

- G - 48" (121.9 cm)
- H - 91.25" (231.8 cm)

Model illustrated: PRN 4050A with RPC-2 dust collector

CABINET

Working Chamber Size

- 50" wide (127 cm)
- 39" deep (99.1 cm)*
- 43" high (109.2 cm)

Window Size (safety glass)

- 19.5" wide (49.5 cm)
- 12.5" high (31.8 cm)

Door Opening

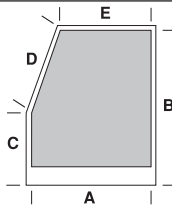

3672A

- A - 32.5" (825 mm)
- B - 34.5" (864 mm)
- C - 19" (483 mm)
- D - 17.5" (444 mm)
- E - 24" (610 mm)

DUST COLLECTORS

ZERO RP dust collectors trap 99.7% of dust particles down to 0.5 micron.

CDC-1

CDC-1 dust collectors come in three sizes; 300 cfm, 600 cfm, and 900 cfm. The cartridges are pulse-cleaned by pressing the manual pulse-valve to clear the filter of dust. Dimensions are 34" wide, 42" deep (with motor housing) and 94" high. MAH is 11 ft for the 300 cfm and 600 cfm units and 12-1/2 ft for the 900 cfm unit.

RPC-2

The RPC-2 has two cartridges which provide 470 sq ft of filter area. The cartridges are automatically pulse-cleaned for maximum filter efficiency. Dimensions are: 56" wide (with motor housing) by 30" deep by 67.5" high. The MAH for the RPC-2 series is 8 ft 10 inches.

RPH-2

The RPH-2 has a filter area of 470 sq ft; the RPH-3 has a 705 sq ft filter area. Both have a built-in hopper to minimize dust-handling. At each pulse, dust falls first into the hopper and then into a disposal drum or bag beneath it. The operator never handles the dust—an important safety feature. RPH dust collector dimensions are: 56" wide (with motor housing) by 36" deep by 115" high. The RPH is designed to allow outdoor installation. The MAH for the RPH collectors is 15 ft 2 inch.

ISO 9001 certified. Clemco is committed to continuous product improvement. Specifications are subject to change without notice.

BLAST/ RECLAIM SYSTEM

Our exclusive media reclaimers continuously extract dust and debris and return usable media to the blast system.

The reclaimer, mounted atop the pressure vessel, automatically refills the blast system with clean, recycled media each time the foot pedal is released.

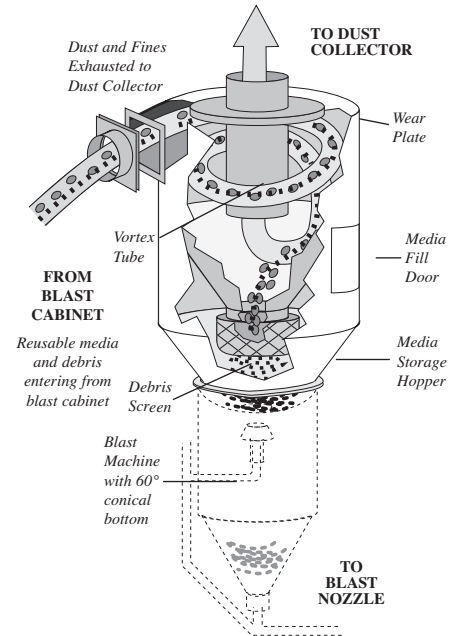

NOZZLES

AIR REQUIREMENTS

NOZZLE	NOZZLE ORIFICE	CFM at 50 PSI	M ³ /Min at 3,5 BAR
No. 5	5/16"	77	2,16*

*4050A is furnished with a TYP-5 tungsten carbide nozzle.

ELECTRICAL

900 CFM (25 m³/m) 2HP, 230/460V, 3PH, 60HZ. Other motors and electrical configurations (such as 50HZ) are available to make your system compatible with local power systems. Consult your local distributor.

ORDERING INFORMATION

Model	Standard Stock No.	Ship Wt. lb (kg)	Model	Ergo Stock No.	Ship Wt. lb (kg)
PDN 4050A CDC-1	28098	1,445(655)	EPDN 4050A	25041	1,490 (676)
PRN 4050A RPC-2	15090	1,815 (823)	EPRN 4050A	25042	1,815 (823)
PRH 4050A RPH	24791	2,390 (1084)	EPRH 4050A	25043	2,390 (1084)

Distributor:

Authorized Distributor:



Fortune Metal Finishing Corp.
116 Gould Street
Needham Heights, MA 02494
866.449.4160
sales@fortunemetal.com