

# BNP DOUBLE 65 and 220 Suction Blast Cabinets O. M. 22963

**DATE OF ISSUE:** 10/00  
**REVISION:** D 07/16

## **NOTICE TO PURCHASERS AND USERS OF OUR PRODUCTS AND THIS INFORMATIONAL MATERIAL**

Clemco proudly provides products for the abrasive blast industry and is confident that industry professionals will use their knowledge and expertise for the safe and efficient use of these products.

The products described in this material, and the information relating to these products, are intended for knowledgeable, experienced users. It is the responsibility of the user to insure that proper training of operators has been performed and a safe work environment is provided.

No representation is intended or made as to: the suitability of the products described here for any purpose or application, or to the efficiency, production rate, or useful life of these products. All estimates regarding production rates or finishes are the responsibility of the user and must be derived solely from the user's experience and expertise, not from information contained in this material.

It is possible that the products described in this material may be combined with other products by the user for purposes determined solely by the user. No representations are intended or made as to the suitability of or engineering balance of or compliance with regulations or standard practice of any such combination of products or components the user may employ.

This equipment is only one component of a cabinet blasting operation. Other products, such as air compressors, air filters and receivers, abrasives, equipment for ventilating, dehumidifying, or other equipment, even if offered by Clemco, may have been manufactured or supplied by others. The information Clemco provides is intended to support the products Clemco manufactures. Users must contact each manufacturer and supplier of products used in the blast operation for warnings, information, training, and instruction relating to the proper and safe use of their equipment.

© 2016 CLEMCO INDUSTRIES CORP.  
One Cable Car Dr.  
Washington, MO 63090  
Phone (636) 239-4300  
Fax (800) 726-7559  
Email: [info@clemcoindustries.com](mailto:info@clemcoindustries.com)  
[www.clemcoindustries.com](http://www.clemcoindustries.com)



## 1.0 INTRODUCTION

### 1.1 Scope of Manual

1.1.1 These instructions cover set-up, operation, maintenance, troubleshooting, optional accessories, and replacement parts for BNP Double 65 and Double 220 dual station suction blast cabinets:

The instructions covers the operation of all pull-thru reclaimers and the installation of the dust collector. One of the following supplemental manuals is provided with the dust collector. Refer to the appropriate manual for operation and maintenance of the collector.

- CDC-1 Dust collectors, manual stock no. ... 28225
- RPC-2 Dust collector, manual stock no. .... 22788
- RPH Dust collectors, manual stock no. .... 21449

1.1.2 The instructions contain important information required for safe operation of the cabinet. Before using this equipment, all personnel associated with the blast cabinet operation must read this entire manual, and all accessory manuals to become familiar with the operation, parts and terminology.

### 1.2 Safety Alerts

1.2.1 Clemco uses safety alert signal words, based on ANSI Z535.4-2011, to alert the user of a potentially hazardous situation that may be encountered while operating this equipment. ANSI's definitions of the signal words are as follows:



**This is the safety alert symbol. It is used to alert you to potential physical injury hazards. Obey all safety messages that follow this symbol to avoid possible injury or death.**

---

## NOTICE

---

**Notice indicates information that is considered important, but not hazard-related, if not avoided, could result in property damage.**

---



---

## CAUTION

---

**Caution indicates a hazardous situation that, if not avoided, could result in minor or moderate injury.**

---



---

## WARNING

---

**Warning indicates a hazardous situation that, if not avoided, could result in death or serious injury.**

---



---

## DANGER

---

**Danger indicates a hazardous situation that, if not avoided, will result in death or serious injury.**

---

### 1.3 General Description

1.3.1 BNP blast cabinets enclose the blasting environment to provide efficient blasting while maintaining a clean surrounding work area. Production rates are influenced by size of nozzle, compressor output, working pressure, type and size of media, angle and distance of the nozzle from the blast surface. BNP suction cabinets consist of three major components:

1. Cabinet Enclosure
2. Reclaimer
3. Dust Collector

1.3.2 **Cabinet Enclosure:** Approximate work chamber dimensions:

**Double 65:** 72" wide x 35" deep x 37" high.

**Double 220:** 100" wide x 39" deep x 43" high.

1.3.3 Refer to Figure 1 for arrangement of components using a CDC-1 dust collector. Figure 2 shows the arrangement with an RPC-2 (900 cfm) reverse-pulse dust collector with dust drawer.

An RPH collector is set up the same way but includes a hopper that is easier to empty and has additional storage. Upgrading to an RPH collector may be done at any time. The overall height of the RPH-2 is approximately 10-feet, 4-inches, and increases to 12-ft when the top access door is open. RPH dust collectors are standard with systems requiring 1200 cfm and larger dust collectors.

### 1.4 Theory of Operation

1.4.1 Once the components are correctly setup and turned ON, the cabinet is ready for operation by actuation of either one or both of the two foot pedals positioned at the operator stations. Fully depressing the foot pedal causes air to flow through the corresponding blast gun. Air moving through the gun draws media into the blast gun mixing chamber. The media mixes with the air and is propelled out the nozzle. After striking the object being blasted, the blast media, fines, dust, and by-products generated by blasting, fall through the mesh work table into the cabinet hopper.

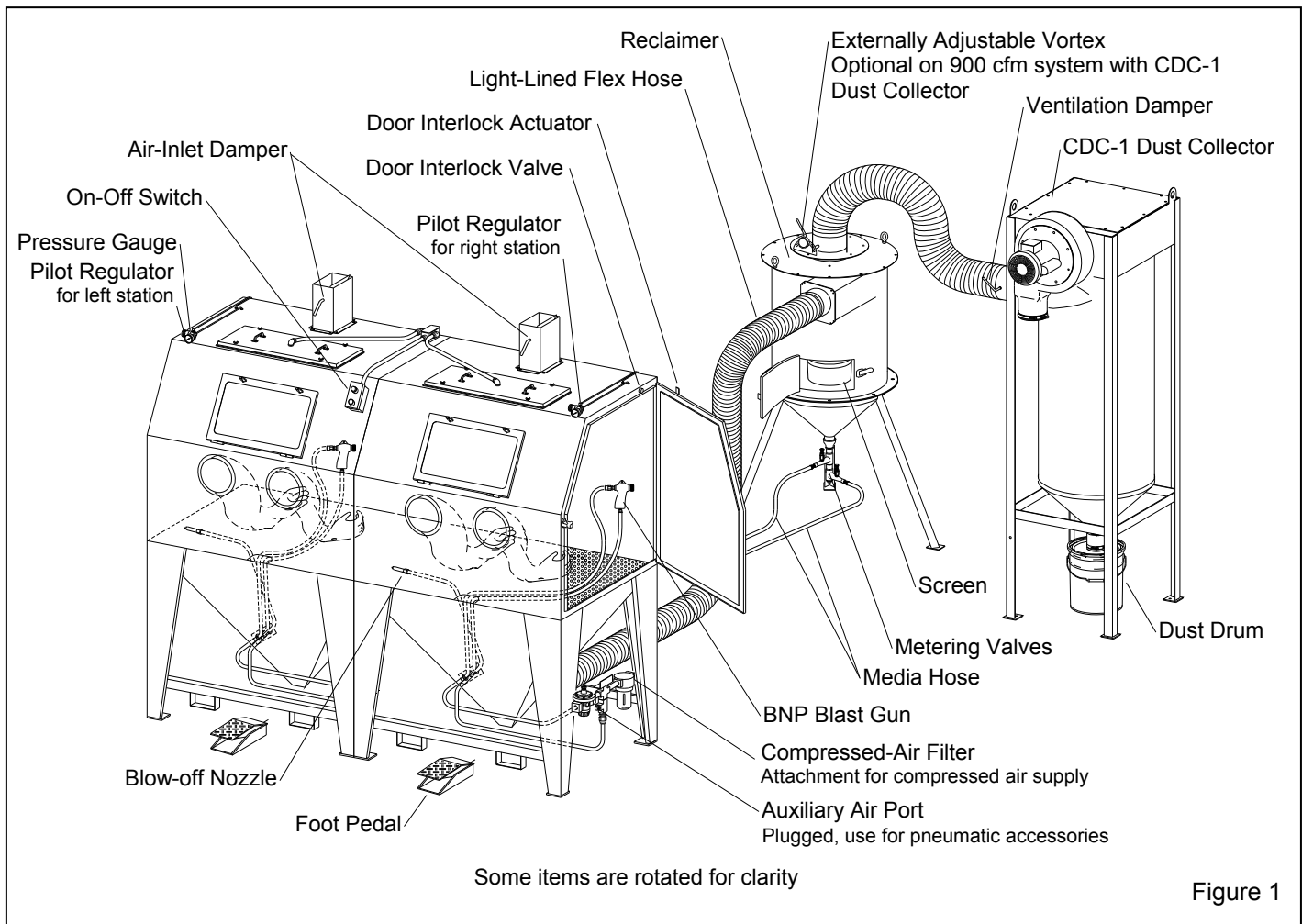

Figure 1

These particles are drawn into the reclaimer for separation. Lightweight dust and fines remain airborne and are drawn out to the dust collector. Heavier reusable media fall through the screen into the reclaimer hopper for reuse. The dust collector traps dust and fines and discharges clean air. When the foot pedal is released, blasting stops.

## 1.5 Reverse Pulse Dust Collector Options

### **⚠ WARNING**

**Prolonged exposure to any dust could result in serious lung disease and death. Short term ingestion of toxic materials, such as lead dust or dust from other heavy metals and corrosives, could cause serious respiratory injury or death. Identify all materials that are to be removed by blasting. Use reverse-pulse dust collectors with HEPA after-filters if lead coating or any other toxic materials are being removed by the blasting process. Do not use dust collectors with simple cloth filters for those applications.**

**1.5.1 CDC-1 Dust Collectors:** Shown in Figure 1, the 900 cfm model collector is available for use with double BNP cabinets. The single filter cartridge is cleaned by using a manually-controlled pulse of compressed air. CDC-1 dust collector is standard with double BNP 900 cfm cabinets unless an optional RPC-2 or RPH dust collector is ordered at time of purchase. Refer to manual number 28225.

**1.5.2 RPC-2 Dust Collectors:** Shown in Figure 2, this collector is available in a 900 cfm models for use with double BNP cabinets. Dual filter cartridges are automatically cleaned by a timed, periodic pulse of compressed air. Dust collects in the drawer and must be frequently emptied. Refer to manual number 22788.

**1.5.3 RPH Dust Collectors:** The RPH-2 (900 cfm model) and RPH-3 (1200 cfm model). It is set up and operates the same as the RPC-2, as shown in Figure 2, but instead of a dust drawer, the collectors sits atop a hopper, which provides additional dust storage, and empties into a drum. Refer to manual number 21449.

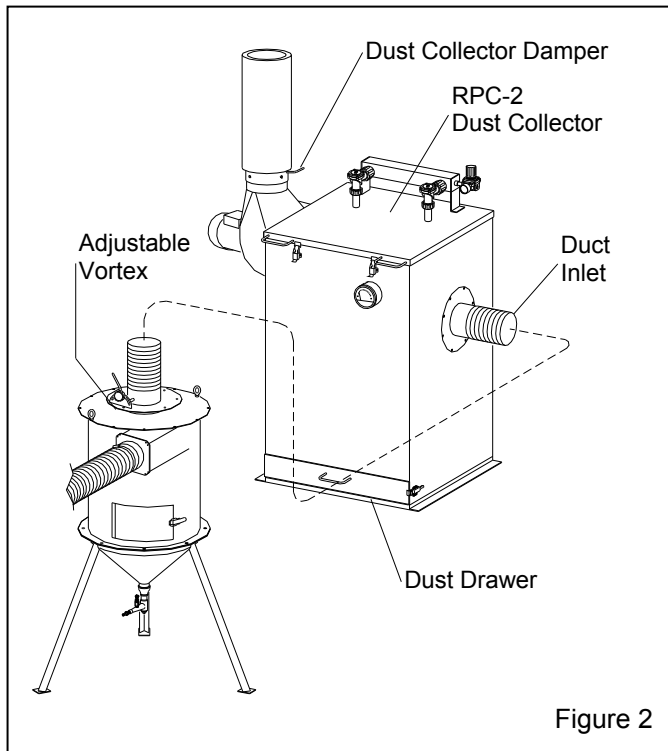

Figure 2

**1.5.4 HEPA (high-efficiency particulate air) Filter:** HEPA after-filters provide additional filtration and must be used with a reverse-pulse cartridge collectors when removing lead coatings or any other toxic materials.

## 1.6 Nozzle Options

**1.6.1** Unless otherwise specified at the time of order, the cabinet is shipped with a No. 5 (5/16" orifice) ceramic nozzles and No. 5 (5/32" orifice) air jets. Optional, more durable tungsten carbide and boron carbide nozzles are available and are shown under Accessories and Replacement Parts in Sections 9.1 and 9.4. Use boron carbide nozzles when blasting with aggressive media, as noted in Section 1.8.4.

## 1.7 Reclaimer Options

**1.7.1** A 900 cfm pull-thru reclaimer utilizes a CDC-1 reverse-pulse dust collector or optional RPC-2 or RPH-2 dust collector.

A 1200 cfm reclaimer utilizes a RPH-3 reverse-pulse dust collector.

**1.7.2** Replaceable rubber reclaimer liners prolong service life of the reclaimer, and should be installed when using silicon carbide, aluminum oxide, or other aggressive media as noted in Section 1.8.4. The reclaimer must be designed to accept liners and have a removable top. Rubber liners are shown in Section 9.1, Figure 29.

## 1.8 Blasting Media

### **⚠ WARNING**

**Obtain Safety Data Sheets (SDS) for the blast abrasive. Abrasive blasting with sands containing crystalline (free) silica can lead to serious or fatal respiratory disease. As NIOSH recommends, do not use abrasives containing more than trace amounts (more than one percent) free silica.**

NOTE: Use only abrasives specifically manufactured for blast cleaning which are compatible with the surface being blasted. Abrasive produced for other applications may be inconsistent in size and shape, contain particles that could jam the abrasive metering valve, or cause irregular wear.

**1.8.1 ZERO** cabinets utilize most common reusable media specifically manufactured for dry blasting. Media sizes listed under media headings and in Figure 3 are for guidelines only. The guidelines are based on standard nozzle size and average conditions, such as blast pressure, media/air mixture, visibility inside the cabinet, humidity, and reclaimer cleaning rate.

Several factors affecting the reclaimer cleaning rate include: reclaimer size (cfm), contamination of parts being blasted, media friability, damper setting (static pressure), and dust collector filter loading (differential pressure across the filter cartridge(s)).

As a rule, larger nozzles deliver more media, requiring higher performance from the reclaimer. When using larger nozzles, the maximum mesh size of media will be smaller than those normally recommended. Using media finer than those recommended may decrease visibility and, increase carryover to the dust collector. Media coarser than those recommended may be too dense for the reclaimer to recover from the cabinet hopper.

**1.8.2 Steel and Shot:** When the recovery hose diameter is suitably sized (usually reduced one size from standard as shown in Figure 3) steel may be used with 1200 cfm reclaimers. When using steel media, conveying hose should have a smooth durable lining, and rubber curtains should be used to protect the cabinet walls from peening and rapid wear. Cabinets configured for steel media use can be ordered from the factory with appropriately sized conveying hose and curtains installed. This special requirement must be specified at the time of order. They may also be field installed at a later date.

**1.8.3 Sand and Slag:** Sand should NEVER be used for abrasive blasting because of the respiratory hazards associated with media containing free silica. Slags rapidly breakdown and are not recyclable, making them unsuitable for cabinet applications.

This table offers a guideline to media selection based on standard 5/16" orifice nozzle (5/32" air jet) and average conditions, (air pressure, media/air mixture, visibility, contamination of parts being blasted, humidity, media breakdown, reclaimer cleaning rate, etc.) As a rule, larger nozzles deliver more media, requiring higher performance from the reclaimer. Larger nozzles decrease the maximum mesh size of media from those recommended. Media that is finer than those recommended may decrease visibility and carryover to the dust collector. Media coarser than those recommended may be too dense to recover from the cabinet hopper.

RECLAIMER SIZE	MEDIA TYPE				
	STEEL GRIT	STEEL SHOT	PLASTIC	GLASS BEAD	ALUM. OXIDE
*900 cfm with 6" inlet	Do not use	Do not use	N/A See 1.8.7	No. 6 to No. 12	46 to 180 mesh
1200 cfm with 6" inlet	40 to 120	S230 to S170	Do not use	No. 4 to No. 8	16 to 60 mesh
*1200 cfm with 7" inlet	Do not use	Do not use	N/A See 1.8.7	No. 4 to No. 12	46 to 180 mesh

\* Standard reclaimer inlets

Figure 3

**1.8.4 Silicon Carbide, Aluminum Oxide, and Garnet:**

These are the most aggressive of the commonly-used media. Aggressive media may be used, but the service life of any components exposed to the media will be reduced. To avoid unscheduled down time, periodically inspect the reclaimer wear plate, flex hoses, blast hose, and nozzle for wear.

When using aggressive media only occasionally, install an optional aluminum oxide kit. The kit includes rubber curtains for the cabinet interior and boron carbide-lined nozzles. When using aggressive media on a regular basis, install an aluminum oxide kit and a fully-rubber-lined reclaimer. NOTE Rubber-lined reclaimers are available as factory-installed items and can be field installed on reclaimers if they have removable tops (designed to accept liners). Nozzles lined with boron carbide extend nozzle wear life. See Optional Accessories in Section 9.1.

**1.8.5 Glass Bead:** Most beads are treated to ensure free-flow operation even in environments of moderately high humidity. Glass beads subjected to excessive moisture may be reused only after thorough drying and breaking up any clumps.

**1.8.6 Lightweight and Fine-mesh Media:** When using lightweight (such as agricultural) media or fine mesh (180-mesh and finer) media, the reclaimer inlet baffle may need to be removed to retain media and avoid carryover. On reclaimer models with bolt-on removable tops, baffle removal and replacement is easily accomplished. Reclaimers with welded-on tops require grinding to remove the baffle and once it is removed it cannot be replaced.

**1.8.7 Plastic Media:** Plastic and similar lightweight and/or non-aggressive media are generally not recommended for suction-style cabinets because the lower blast velocity of suction blasting combined with the softer and lighter weight media, do not provide the media impact for productive blasting. Best performance from plastic media is achieved with pressure blasting,

requiring a pressure vessel with a 60-degree conical bottom. Refer to Clemco's AEROLYTE cabinet line.

**1.8.8 Bicarbonate of Soda:** Bicarbonate of soda is not recommended for use in standard cabinets. Bicarb is a one-use media usually used and will quickly saturate the filter cartridge(s). Best performance from bicarb media is achieved with pressure blasting, requiring a pressure vessel. Refer to Clemco's AEROLYTE cabinet line for cabinets that are specifically designed for use with bicarbonate of soda.

**1.9 Compressed Air Requirements**

**1.9.1** The size of the compressor required to operate the cabinet depends on the size of the air jet and blasting pressure. Unless otherwise specified, cabinets are supplied with a No. 5 (5/32" orifice) jet. Refer to the table in Figure 4 to determine cfm consumption for each gun. When operating with both guns the cfm consumption is double from that shown. Consult with a compressor supplier for suggested compressor size based on the air consumption. **NOTE: A separate air line is required for the reverse-pulse dust collector.**

BNP Gun	Jet	Nozzle	**CFM	PSI
No. 4	1/8"	5/16"	21	80
No. 5	5/32"	5/16"	32	80
No. 6	3/16"	3/8"	47	80
*No. 7	7/32"	7/16"	62	80
*No. 8	1/4"	1/2"	86	80

\* Using this combination could affect usable media size, refer to Section 1.8.  
 \*\* When operating with both guns cfm consumption is doubled.

Figure 4

**1.9.2** The air filter at the air inlet connection reduces condensed water from the compressed air. Its use is especially important in areas of high humidity, or when using fine-mesh media. Moisture causes media to clump and inhibits free flow through the feed assembly. If the filter does not remove enough moisture to keep media dry and flowing, it may be necessary to install an air dryer or aftercooler in the air supply line.

### 1.10 Electrical Requirements

All wiring external to the cabinet is provided by the user to comply with local electrical codes.

**1.10.1** Electrical requirements depend on the size and phase of the dust collector exhaustor motor. NOTE: Full load amps (FLA) shown below are for the motor only; the lights draw less than one amp. Standard cabinets are supplied as follows:

900 cfm: 2 HP, 208/230/460V, 3-PH, 60 HZ  
Supplied with 230-volt control panel unless 460-volt is specified at the time the order is placed.  
FLA 208/5.5, 230/5.6, 460/2.8.

1200 cfm: 5 HP, 208/230/460V, 3-PH, 60 HZ  
Supplied with 230-volt control panel unless 460-volt is specified at the time the order is placed.  
FLA 208/12 to 13, 230/12 to 13, 460/6.

Additional wiring information is in Section 2.5.

## 2.0 INSTALLATION

### 2.1 General Installation Notes

**2.1.1** Refer to Figure 1 (and Figure 2 for optional RPC-2 dust collector) for the general arrangement. Place all components in a convenient location where compressed air and electrical service are available. The cabinet location must comply with OSHA and local safety codes. Allow for full access to all doors and service areas, and for efficient handling of large parts. Provide enough clearance at the dust collector for maintenance and to remove the dust container. Place the reclaimer directly behind the cabinet with flex hose connection and metering valve facing toward the cabinet to allow for as few bends as possible. Determine the best location for all components and position them before making compressed air connections, electrical connections, and attaching flex hose.

**2.1.2** Refer to the dust collector owner's manual to set up the dust collector and prepare it for operation.

### 2.2 Connect Conveying Hose, Figure 5

**2.2.1** Connect the two smallest diameter flex hoses between the cabinet hopper adaptor pipes and wye pipe adaptor. It is easier to slip the hose over the pipes and adaptor and to create a tighter seal if the first two or three inches of wire are removed from the inside of the hose. Use care not to damage the hose. NOTE: The hose wire helps dissipate static electricity in the conveying hose, and also helps ground each segment. In order for the hose wire to dissipate static electricity, the wire must touch the metal of each segment. Clamp the flex hose securely with worm clamps provided.

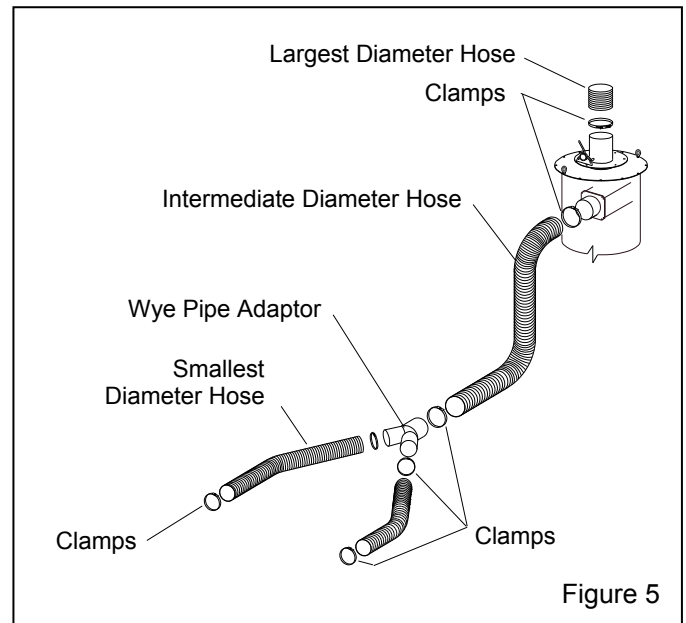

Figure 5

**2.2.2** Connect the intermediate diameter flex hose between the wye pipe and reclaimer inlet adaptor. Clamp the flex hose securely with worm clamps provided.

**2.2.3** The largest diameter hose attaches to the reclaimer outlet, which will later be connected to the dust collector.

### 2.3 Connect Compressed Air Supply Line(s)

## ⚠ WARNING

**Failure to observe the following before connecting the equipment to the compressed air source could cause serious injury or death from the sudden release of compressed air.**

- Lockout and tagout the compressed air supply.
- Bleed the compressed air supply line.

**⚠ WARNING**

To avoid the risk of injury from compressed air, install an isolation valve and bleed-off valve where the air supply is tapped into the compressed air system. This enables depressurization of the compressed-air line before performing maintenance.

2.3.1 Refer to Paragraph 2.3.2 to determine the recommended air supply hose size, then refer to Figure 6 and apply thread sealant to the male threads of an air fitting that is compatible with the air supply hose fitting, and install it onto the 1/2-NPT air filter located under the cabinet hopper. **Note that the style of connection shown in Figure 6 is for reference only.**

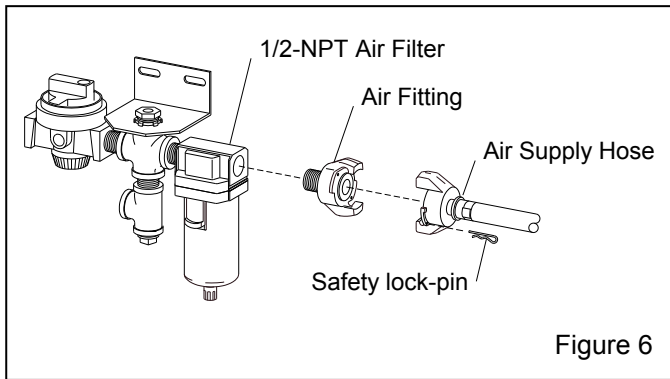

Figure 6

2.3.2 Refer to the table in Figure 7 to determine the minimum ID air supply line to the cabinet air inlet. A smaller diameter hose may reduce blasting efficiency.

2.3.3 Connect the air line from the air source to the air filter inlet.

MINIMUM COMPRESSED AIR LINE ID			
Air Line Length	Air Jet Size		
	No. 4	No. 5	No. 6
25 feet	3/4"	3/4"	1"
50 feet	3/4"	3/4"	1"
75 feet	3/4"	1"	1"
100 feet	3/4"	1"	1"

Figure 7

**⚠ WARNING**

If twist-on type air hose couplings are used, they must be secured by safety pins or wires to prevent accidental disconnection while under pressure. Hose disconnection while under pressure could cause serious injury.

2.3.4 Refer to the dust collector owner's manual and connect a compressed-air line to the pulse manifold.

2.4 Ground Cabinet

2.4.1 To prevent static electricity build up, attach an external grounded wire from an earth ground to the grounding lug on the left rear of the cabinet.

2.5 Connect Electrical Service

**⚠ WARNING**

Lockout and tagout the electrical supply before performing any electrical service. Shorting electrical components could result in death, serious injury from electrical shock, or equipment damage. All electrical work, or any work done inside an electrical panel, must be performed by qualified electricians, and comply with applicable codes.

All wiring external to the cabinet is provided by the user to comply with local electrical codes.

NOTE: a wiring schematic is packed inside the cabinet's control panel. After wiring is completed, keep a copy of the schematic with the manual for future reference and for electrical replacement parts.

2.5.1 Three-Phase Wiring

2.5.1.1 Refer to the wiring schematic stowed inside the control panel mounted on the cabinet and wire from the users disconnect to the panel and from the panel to the dust collector motor, per instruction on the motor data-plate

2.5.1.2 Check the amperage on initial start up; if the motor draws excessive amperage, gradually close the dust collector damper, located on the inlet on CDC dust collectors, and on the exhaustor outlet on RPC and RPH dust collectors, until the amperage is within the specifications shown on the motor plate.

2.5.2 Check Motor Rotation

2.5.2.1 After wiring is completed, observe the warning that follows and check the motor rotation. To check rotation, turn the On-Off switch ON and quickly turn it OFF, causing the motor to rotate slowly. Look through the slots in the motor fan housing where rotation of the fan can easily be observed. Proper rotation is indicated by the arrow on the exhaustor housing; the fan should rotate toward the exhaustor outlet. If it rotates in reverse, change the wires as noted on the motor plate to reverse rotation.

## ⚠ WARNING

**Do not look into the exhauster outlet while the paddle wheel is turning. Injury to the eye or face could occur from objects being ejected from the exhauster.**

### 2.6 Cabinet Air-Inlet Dampers, Refer to Figure 8

**2.6.1** The air-inlet dampers are located on the top of the cabinet and must be set to match the cabinet dimensions and reclaimers size. The air-damper was preset prior to shipment; confirm the initial setting as noted below.

**2.6.2** The label on the damper show the settings in degrees. The initial setting should align the handle as noted below.

Double 65 w/900 ..... align handles to 30 degree  
 Double 65 w/1200 ..... align handles to 30 degree  
 Double 220 w/900 ..... align handles to 30 degrees  
 Double 220 w/1200 .align handles to 0 degree (full open)

Loosen the lock nuts and align the damper handles as noted. When correctly positioned, tighten the lock nuts to maintain the setting.

Refer to Section 5.6 for adjustment procedure.

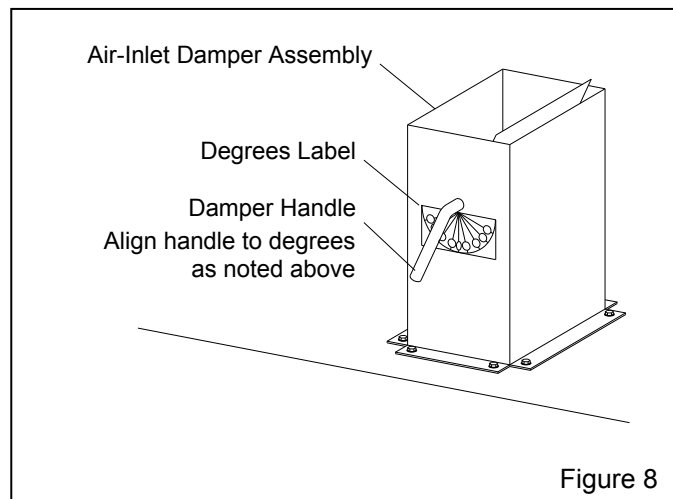

### 2.7 Final Assembly

**2.7.1** Position the foot pedals on the floor at the front of the cabinet.

**2.7.2** A package of five view-window cover-lenses is supplied with the cabinet. Install a cover lens per Section 7.3. When the cover lens becomes pitted or frosted, replace it.

### 3.0 FIELD INSTALLED ACCESSORIES

Optional accessories are shown in Section 9.1

#### 3.1 Aluminum Oxide Kit

**3.1.1** An optional aluminum oxide kit is available factory installed or may be field installed later.

Filed-installed (or replacement factory installed) kits consist of black rubber curtains with grommets, curtain hardware, boron carbide nozzle and light-lined flex hose. If the existing flex hose is in good condition, reserve the new hose for future replacement.

#### 3.2 Curtain Installation

**3.2.1** Match curtains to corresponding wall and doors.

**3.2.2 Front and rear walls:** Position the curtains on the wall to be protected. Use the curtains as templates to mark each mounting point through the grommet holes along the upper edge of the curtain. NOTE: When laying out the attachment points, the upper edge of the rear curtain should be below the bottom edge of the air duct partition. Remove the curtains, and drill a .187" (3/16") diameter hole at each point marked. Install the curtains using the fasteners provided (machine screw, 11/16" OD flat washer, lock washer and nut) at each grommet. The flat washer is used between the screw head and the rubber curtain grommet on all curtains.

**3.2.3 Doors:** Using protectors against the curtains and outer doors, clamp the door curtains in place. NOTE: When laying out the attachment points, the upper edges of the door curtains should be even with the outer edges of the door's sound proofing panel. Insert a #10 self-drilling screw with an 11/16" OD flat washer through the grommet holes. Use a screw gun with a 5/16" socket to drill and thread the screws through the door's inner wall at each grommet.



### 3.3 Manometer

The optional manometer kit is listed in Section 9.1.

**3.3.1** Consistent static pressure is necessary for precise media separation, as the reclaimers efficiency is achieved by a centrifugal balance of air flow, particle weight, and size. The manometer measures static pressure. Reclaimer static pressure is set by adjusting the dust collector ventilation-damper. Refer to Section 5.4 to adjust static pressure. Refer to Section 5.8 for instructions on using the manometer.

### 3.4 Armrest

**3.4.1** Assemble the armrest and mounting brackets as shown in Figure 9.

**3.4.2** Position the assembly so the armrest is about even with the bottom of the arm-port opening. Mark one hole location on the front of the cabinet at each mounting bracket.

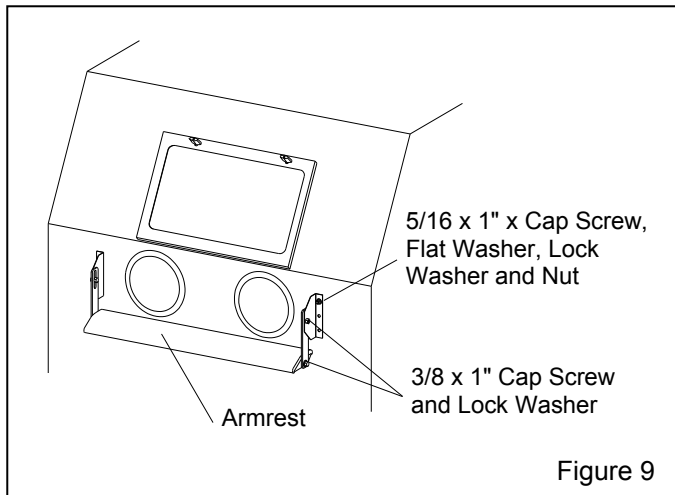

Figure 9

**3.4.3** Drill a 3/8" hole at both locations and mount the armrest using 5/16 cap screw, washers and nuts. Install the bolts from inside the cabinet to protect the threads from abrasion, should the armrest need to be removed at a later date.

**3.4.4** Match drill the remaining four bracket holes and install the remaining fasteners.

**3.4.5** Loosen the fasteners on the slotted bracket and raise or lower the armrest to a comfortable position.

### 3.5 Turntable with Workcar and Track

**3.5.1** Components of the turntable and track assembly are shown in Figure 10. The assembly consists of:

1. The inside track assembly, which is placed inside the cabinet.
2. The hinged track extension attaches to the support table, swings up to clear the door.
3. The track support table.
4. Turntable and workcar assembly.

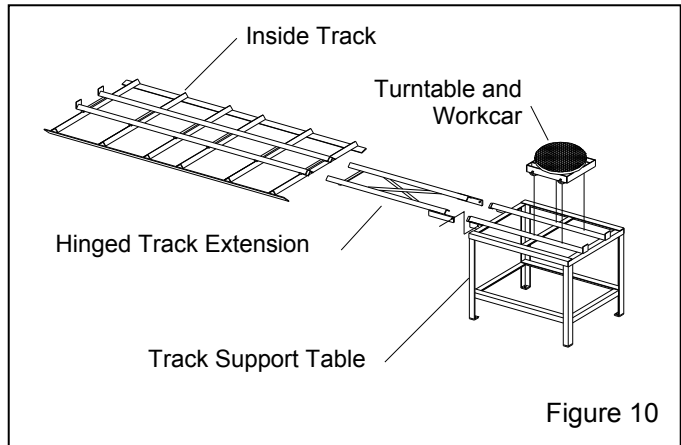

Figure 10

**NOTE:** The track may be placed on either side of the cabinet, allowing entry through either door. When installing the inside track, place it so the stops are opposite the entry door.

**3.5.2** Place the inside track in the cabinet over the existing grate as shown in Figure 11.

**3.5.3** Position the track support table and extension as shown in Figure 12. When the hinged extension is lowered, the extension tracks must rest on the angled locating supports welded to the bottom of the inside tracks, and butt against the inside tracks.

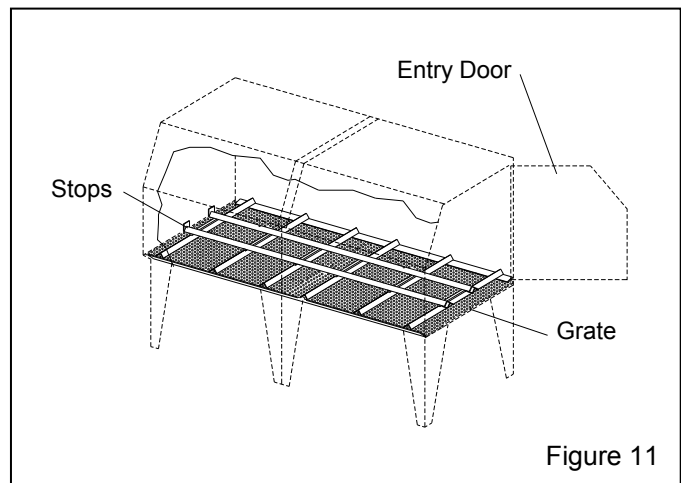
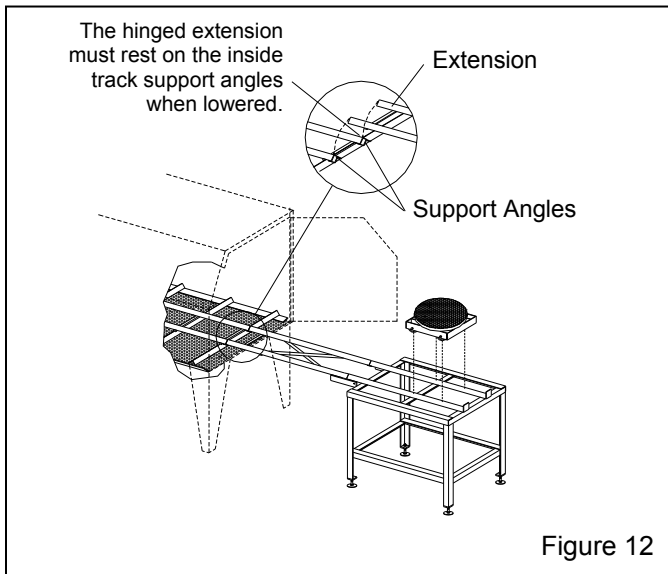

Figure 11



**3.5.4** Holes are provided on the track table leg pads to permit anchoring when needed.

**3.5.5** Raise the track extension to allow opening and closing of the door.

## 4.0 OPERATION

### 4.1 Media Loading and Unloading

**4.1.1 Media Loading:** With the exhauster OFF, add clean dry media by pouring it into the reclaimer hopper through the reclaimer door. Do not fill above the cone on the reclaimer. **Do not pour media directly into the cabinet hopper, as overfilling may occur.** Overfilling will result in media carryover to the dust collector and possible blockage in the conveying hose. Refill only after all media has been recovered from the cabinet.

The minimum amount of media to charge the system is as follows:

900 cfm reclaimer .....	40 lbs. media
1200 cfm reclaimer .....	75 lbs. media

**4.1.2 Media Unloading:** To empty the cabinet and reclaimer of media, blow-off the cabinet interior and run the exhauster until all media is recovered from the cabinet. Turn OFF the exhauster, and place an empty container under the reclaimer's metering valve. Unscrew the plastic plug from the metering valve, permitting media to flow into the container. If media doesn't flow, it has caked. Open the fill door and stir media until it starts to flow. Replace the plug when the reclaimer is empty.

### 4.2 Loading and Unloading Parts

## ⚠ WARNING

**Use solid fixturing to hold heavy parts in place. Do not remove lift equipment until the part is adequately supported to prevent movement. Moving heavy, unsupported parts may cause them to shift or topple, and cause severe injury. This is especially important with the use of turntables and turntables with tracks.**

**4.2.1** Load and unload parts through either door.

**4.2.2** Parts must be free of oil, water, grease, or other contaminants that will clump media or clog filters.

**4.2.3** When blasting small parts or objects having small pieces that could become dislodged and fall off, place an appropriately-sized screen over the grate (or under the grate when frequently blasting small parts) to prevent parts from falling into the hopper.

**4.2.4** Close door; the door interlock system will prevent blasting if either door is open.

### 4.3 Blasting Operation

## ⚠ CAUTION

- **Always close cabinet, reclaimer and dust collector doors before blasting. Keep all doors closed during blasting.**
- **Always wear blast gloves.**
- **Avoid pointing the blast nozzle toward the view window.**
- **Use the blow-off gun to blow media off parts before opening doors.**
- **After blasting, keep doors closed and exhauster running until the cabinet is clear of all airborne dust.**
- **Stop blasting immediately if dust leaks are detected.**

**4.3.1** Slowly open the air valve on the air supply hose to the cabinet. Check for air leaks on the initial start up, and periodically thereafter.

**4.3.2** Turn ON the lights and exhauster. The ON/OFF switch performs both functions.

**4.3.3** Load parts through either door.

**4.3.4** Close door; the door interlock system will prevent blasting if either door is open.

**4.3.5** Adjust the pilot pressure regulator to the required blast pressure, per Section 5.1. The regulators are located on the top, front edge of the cabinet at the corresponding operator station.

**4.3.6** Insert hands into rubber gloves.

**4.3.7** To blast, hold the gun firmly, point the gun toward the object to be blasted, and apply pressure to the foot pedal; blasting will begin immediately.

## **⚠ WARNING**

**Shut down the cabinet immediately if dust discharges from the dust collector or cabinet. Make sure the dust collector filter(s) are correctly seated and not worn or damaged. Prolonged breathing of any dust could result in serious lung disease or death. Short term ingestion of toxic dust such as lead, poses an immediate danger to health. Toxicity and health risk vary with type of media and dust generated by blasting. Identify all material being removed by blasting, and obtain a safety data sheet (SDS) for the blast media.**

NOTE: When blasting parts off the grate, use a solid conductive back rest to support the part. Without this assist, especially with longer blasting operations, the operator will tire easily from resisting blast pressure, and static electricity could build up in the ungrounded part and cause static shocks. Whenever possible avoid holding small parts that require blasting into the glove.

**4.3.8** If an object should fall through the grate, stop blasting immediately and retrieve it.

## **4.4 Stop Blasting**

**4.4.1** To stop blasting, remove pressure from the foot pedal.

**4.4.2** Use the blow-off gun to blow media off cleaned parts.

**4.4.3** Keep doors closed and exhauster running until the cabinet is clear of all airborne dust.

**4.4.4** Unload parts. Shut off the air supply valve, drain the air filter, and switch OFF the lights and exhauster.

## **4.5 Blasting Technique**

**4.5.1** Blasting technique is similar to spray painting technique. Smooth continuous strokes are most effective. The distance from the part affects size of blast pattern. Under normal conditions, hold the nozzle approximately 3" to 6" from the surface of the part.

## **5.0 ADJUSTMENTS**

### **5.1 Blasting Pressure**

**5.1.1** The pilot regulators, located on the top, front edge of the cabinet, enables the user to adjust blasting pressure to suit the application. The suitable pressure for most purposes is about 80 psi. Lower pressures may be required on delicate substrates, and will reduce media breakdown. Higher pressure may be required for difficult blasting jobs on durable substrates, but will increase media break down. If pressure is too high, suction in media hose will decrease, and if high enough, cause blow-back in the hose. Optimal production can only be achieved when pressure is carefully monitored.

**5.1.2** To adjust pressure, unlock the knob by pulling it out as shown in Figure 13, and turn it clockwise to increase pressure or counter-clockwise to decrease pressure. Pressure will usually drop from closed-line pressure when blasting starts. Once operating pressure is set, push the knob in to lock it and maintain the setting.

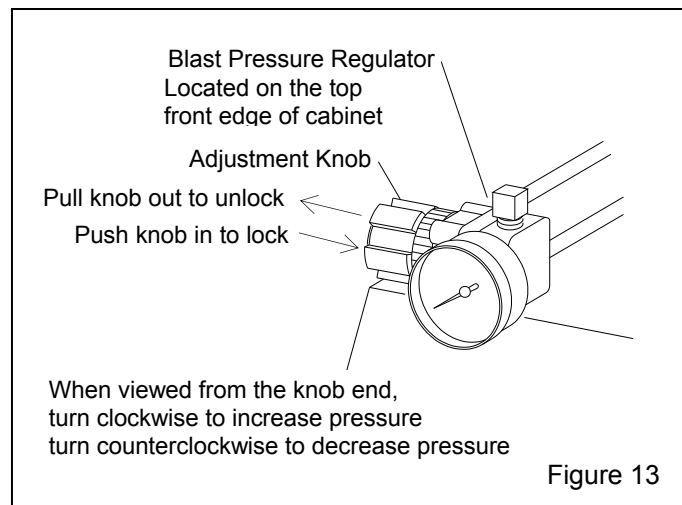

### **5.2 Air Jet Adjustment, Figure 14**

**5.2.1** Thread the air jet 4-1/2 to 5 full turns into the gun body. Doing so will leave 3-1/2 to 4 threads exposed past the lock nut. Tighten the lock nut to maintain the setting. Refer to Section 9.4, item 16 for the optional adjusting tool, which correctly positions the jet.

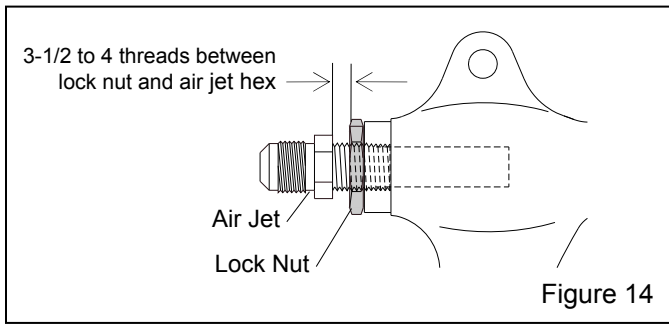

Figure 14

**5.3 Media/Air Mixture, Figure 15**

NOTE: Each metering valve must be adjusted independently.

**5.3.1** Check the media stream for correct media/air mixture; media flow should be smooth and appear as a light mist coming from the nozzle.

**5.3.2** If media does not flow smoothly, loosen the locking nut and adjust the metering screw until the upper holes in the metering stem are closed-off, and the lower holes are fully open, as shown in Figure 15. This adjustment is a starting point.

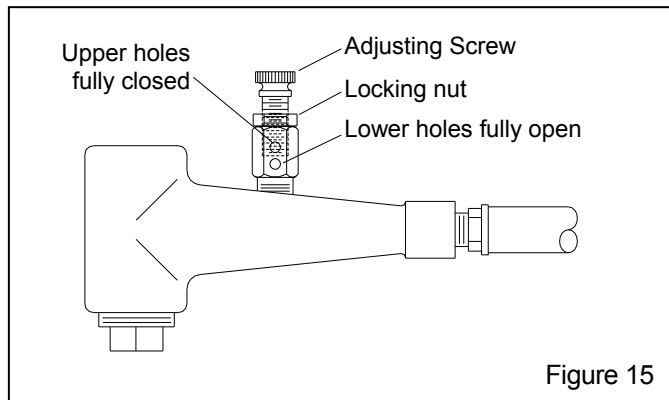

Figure 15

**5.3.3** If pulsation occurs in the media hose, either media is damp and caked, or not enough air is entering the media stream. While blasting, loosen the locking nut and slowly turn the adjusting screw out (counterclockwise when viewed from the top) until media flows smoothly. Tighten the locking nut finger-tight to maintain the setting.

**5.3.4** If media flow is too light, decrease air in the mixture by turning the metering screw in (clockwise when viewed from the top) covering more of the holes so less air enters the media hose. Tighten the locking nut finger-tight to maintain the setting.

**5.4 Reclaimer Static Pressure**

**5.4.1** Correct static pressure varies with size of reclaimer and the size, weight and type of media.

**5.4.2** Adjust static pressure by opening (handle inline with air flow) or closing (handle perpendicular to air flow) the dust collector ventilation damper. Refer to the dust collector owner's manual, the damper is located on the inlet on CDC-1 dust collectors, and on the exhaust outlet on RPC and RPH dust collectors. If the damper is not opened far enough, the reclaimer will not remove fines, resulting in dusty media, poor visibility, and possible media blockage in the conveying hose. If the damper is opened too far, it may cause carryover (usable media carried into the dust collector) and result in excessive media consumption. Open only as far as necessary to obtain a balance of dust removal without media carryover.

**5.4.3** A manometer is useful when adjusting or monitoring static pressure. The manometer kit is listed under Optional Accessories in Section 9.1. Refer to Section 5.8 for manometer operation. The following are static pressure starting points for given media. Static pressure may need to be lower with finer media, higher with coarser media. Run the media through several blast cycles allowing the reclaimer to function with these settings. Inspect the media in the reclaimer and fines in the dust collector as noted in Paragraph 5.4.2. Continue adjusting static pressure until optimum media cleaning without carryover is attained.

Glass Bead No. 4 to 7 .....	3" to 3-1/2"
Glass Bead No. 8 to 13 .....	2-1/2 - 3"
Alox. 60 & coarser .....	4 - 5"
Alox. 80 & finer .....	2-1/2 - 3"
Steel Grit .....	6 - 7"

**5.4.4** If the damper has been adjusted and carryover or excessive dust in the media continues to be a problem, adjust the Vortex tube per Section 5.5.

**5.5 Externally-Adjustable Vortex Cylinder**

NOTE: The externally adjustable vortex is an option when the cabinet is provided with a CDC-1 Dust collector. The vortex is standard with reclaimers when the cabinet is provided from the factory with an RPC or RPH dust collector.

NOTE: The vortex cylinder fine-tunes media separation. Before adjusting the cylinder, adjust the damper on the dust collector to increase or decrease static pressure per Section 5.4. Once the damper is adjusted, adjust the cylinder.

**5.5.1** The vortex cylinder is located atop the reclaimer where the flex hose connects. Adjustments are made by loosening the handle's tensioning knob and moving the handle to achieve the correct setting. When the correct setting is established, tighten the locking knob to prevent movement. Start with the lever slightly to the right (about one o'clock position as shown in Figure 16) of the vertical position.

**5.5.2 To Remove More Fines:** (Too much dust in media) Raise the cylinder by moving the lever left toward "COARSE", in 1/4" increments at the indicator plate. Allow the media to go through several blast cycles before determining if further adjustment is required.

**5.5.3 To Remove Less Fines:** (Excessive usable media is carried to the dust collector) Lower the vortex cylinder by moving the lever right toward "FINE", in 1/4" increments at the indicator plate. NOTE: If the cylinder is lowered too far, the reclaimers will again begin to allow usable media to be carried over, and cause abnormally high static pressure.

**5.5.4** When using media finer than 180-mesh, the inlet baffle of the reclaimers may need to be removed. Refer to Section 1.8.6.

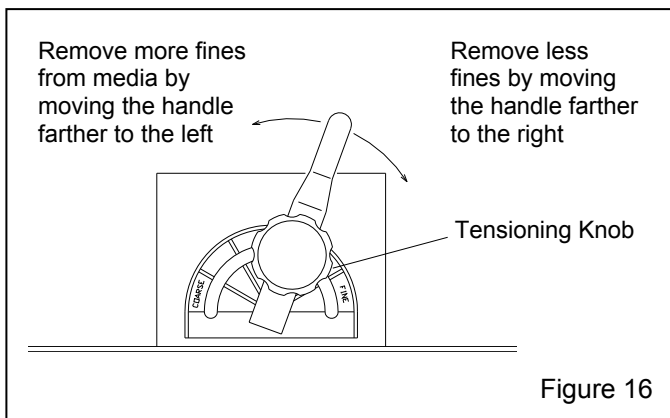

## 5.6 Cabinet Air-Inlet Dampers

**5.6.1** Once the inlets are initially set per Section 2.6, it seldom requires readjustment. The initial setting produces approximately .5" to .75" of static pressure in the cabinet enclosure. **Do not confuse cabinet static pressure with reclaimers static pressure, which is controlled by the dust collector ventilation-damper as noted in Section 5.4. Reclaimer pressure must be set before cabinet pressure.**

**5.6.2** Using a manometer (as noted in Section 5.8 and listed in Section 9.1) is the most accurate method of monitoring and adjusting cabinet pressure. Following the instructions packed with the manometer, start the exhauster and insert the needle into a glove, and adjust pressure using the cabinet's air-inlet damper. Open the damper farther to decrease static pressure or close it farther to increase pressure.

**5.6.3** If a manometer is not available, use the gloves as an indicator. With the exhauster ON, the gloves should be inflated, but not elevated off the grate.

## 5.7 Door Interlocks, Figure 17

### **⚠ WARNING**

**Never bypass the door interlock system. Doing so could result in injury from unexpected blasting.**

**5.7.1** The door interlocks disable the blasting control circuit when doors are open. To enable blasting, the door interlock switches must be engaged when doors are closed. The interlocks are set at the factory and do not normally require field adjustment unless parts are replaced. When adjustment is required, proceed as follows.

**5.7.2** Close cabinet doors.

**5.7.3** Loosen the actuator bracket screws and adjusting screw nut. Move the actuator adjusting bracket up or down, and the adjusting screw sideways, to center the adjusting screw on the over-travel stop. Tighten the bracket screws.

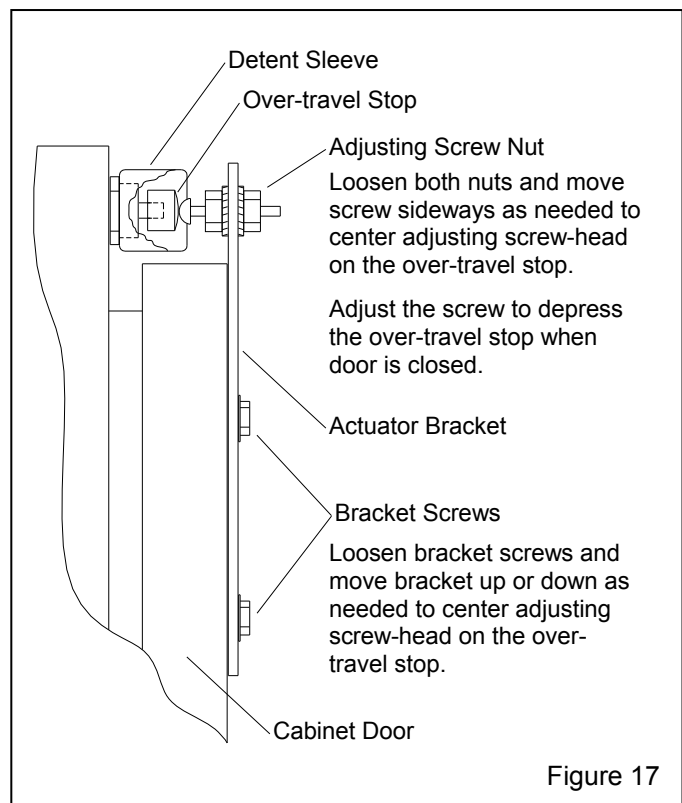

**5.7.4** Turn the adjusting screw in or out as required to engage the switch without applying excessive pressure on it. Tighten the adjusting screw nuts.

**5.7.5** Test the operation with the doors open and then again closed. Point the nozzle away from the door during the tests, and open the door only enough to disengage

the interlock switch. The interlocks should stop the blasting when the doors are opened, and permit blasting when the doors are closed. NOTE: Negative pressure inside the cabinet may cause the doors to flex inward. Tests should be performed with the exhauster running.

## 5.8 Optional Manometer

These instructions show several methods of taking static-pressure readings (negative pressure) on cabinet reclaimers, using a flexible tube manometer. Use the method best suited for the application. The instruction explains the processes for taking periodic readings and shows how to permanently install the manometer for taking frequent readings. Permanent fittings should be installed when rigid ducting is used, or when the manometer installation is permanent. Use silicone sealer or other sealant to seal around the fitting to prevent leaks. The fitting should be capable of being capped when the manometer tube is removed. Capping the fitting will prevent leaks that alter the reclaimer's separation efficiency. The readings are reference points so it doesn't matter where the readings are taken as long as they are always taken at the same location. Taking readings at different locations could produce different results. Static-pressure readings at the door are generally .5" to 1" lower than those taken above the reclaimer.

**5.8.1** Refer to directions packed with the manometer for preparation and operating instructions for the manometer.

**5.8.2** Connect one end of the 3/16" ID tubing to one of the tubing connectors (elbow) at the top of the manometer by pushing it over the barbed adaptor.

**5.8.3** Leave the needle protector on the needle and insert the needle into the other end of the tubing. The ends of the tubing must fit tight on the manometer and needle; leaks will give inaccurate readings.

**5.8.4** Open both manometer valves (elbows) per the instructions provided with the manometer.

**5.8.5** Magnets on the manometer hold it in position on the reclaimer body. The manometer must be vertically-plumb so the fluid is level on both sides.

**5.8.6** Adjust the slide rule to align the zero with the fluid level. Refer to Figure 19

**5.8.7** Needle placement: Ref. Figure 18.

**5.8.7.1 Taking readings in the flex hose:** Remove the needle protector, and insert the needle into the flex hose approximately 8" from the top of the reclaimer.

**5.8.7.2 Taking readings at the reclaimer door:** Open the reclaimer fill door, remove the needle protector and place the needle so the point is inside the door opening. Carefully close the door on the needle. The side of the needle will embed into the rubber, creating an airtight seal.

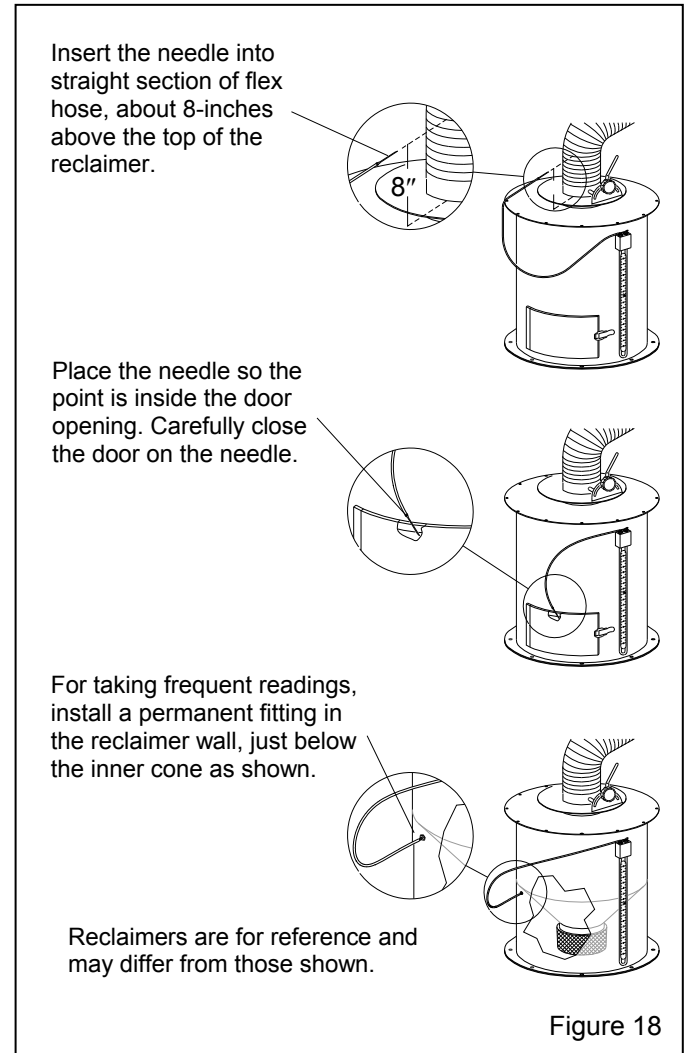

**5.8.8** Turn the exhauster ON. The negative (static) pressure will move fluid in the tube.

**NOTE: Readings must be taken with the cabinet doors open, and with the exhauster running.**

**5.8.9** To find the static pressure, add the number of inches the fluid travels up one column to the inches the fluid travels down the other column. Refer to the example in Figure 19.

**5.8.10** After the readings are taken, replace the needle protector. Close the manometer valves and store the manometer in the original container in a clean area. NOTE: If the manometer installation is permanent, the manometer may remain on the reclaimer body after the valves are closed.

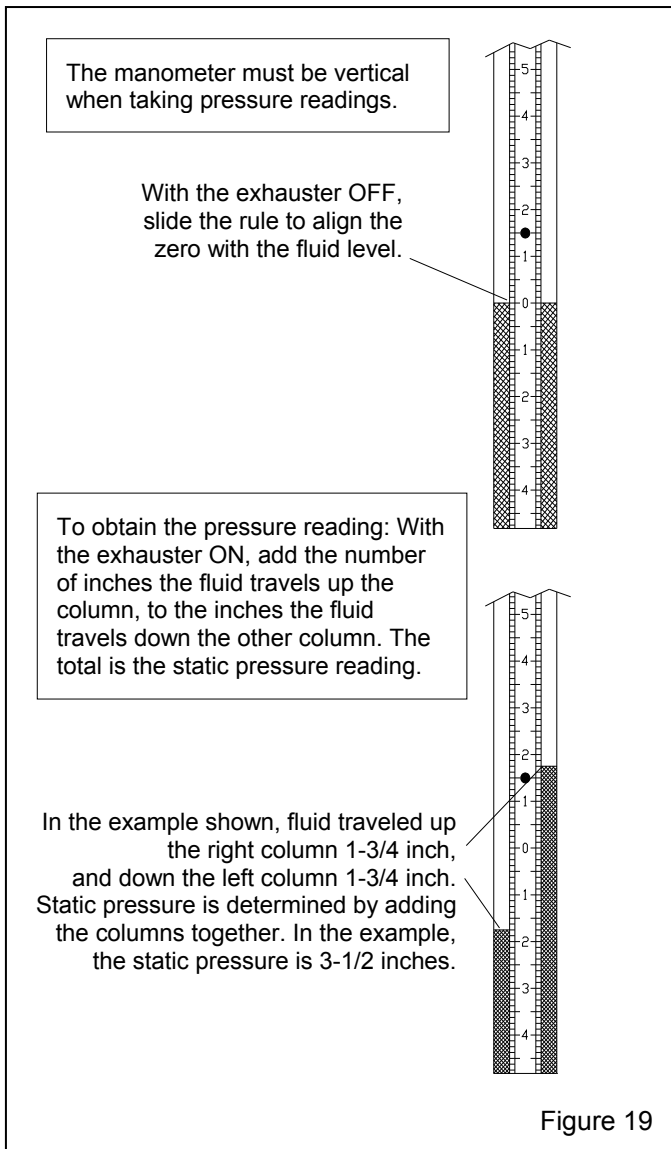

## 6.0 PREVENTIVE MAINTENANCE

NOTE: To avoid unscheduled downtime, establish an inspection schedule. Inspect all parts subjected to media contact, including; the gun, nozzle, media hose, flex hose, wear plate, plus all items covered in this section.

### 6.1 Daily

**6.1.1** Check media level in reclaimer and refill as necessary.

**6.1.2** Check reclaimer debris screen for debris. The screen is accessible through the reclaimer door. With the exhauster OFF, remove the screen and empty it daily or when loading media. Empty the screen more often if part blasted causes excessive debris. Do not operate the machine without the screen in place, oversized byproduct from blasting could plug the nozzle.

**6.1.3** The cabinet is equipped with a manual-drain air filter. Drain the filter at least once a day, and more often if water is present. Moist air inhibits the flow of media. Drain the air line and receiver tank regularly. If the filter does not remove enough moisture to keep media dry and flowing, it may be necessary to install an air dryer or aftercooler in the compressed-air supply line.

**6.1.4** Refer to the dust collector owner's manual and empty dust containers. Adjust intervals based on filling rate.

**6.1.5** Refer to the dust collector owner's manual and drain the pulse manifold at the end of each shift.

**6.1.6** Refer to the CDC-1 dust collector manual for pulsing instructions and pulse the cartridge at least every half hour of blasting and before turning OFF the exhauster. Dusty blasting conditions will require more frequent pulsing. RPC and RPH dust collectors are automatically pulsed at timed intervals.

### 6.2 Weekly

**6.2.1** Inspect view window cover lens, Replace as needed per Section 7.3.

**6.2.2** Inspect gloves for wear. The first sign of deterioration may be excessive static shocks. Replace as needed per Section 7.1.

**6.2.3** Inspect internal parts of the BNP gun for wear. Replace parts as needed per Section 7.2.

**6.2.4** Inspect flex hoses for wear.

**6.2.5** During operation, inspect cabinet door seals for media leaks.

**6.2.6** Inspect the media hose for thin spots, by pinching it every 6 to 12 inches. Replace the hose when it becomes soft.

### 6.3 Monthly

**6.3.1** Inspect reclaimer wear plate or rubber liners for wear. Replace as necessary per Section 7.8 or 7.9.

**6.3.2** Inspect reclaimer door gasket for wear or other damage.

### 6.4 Dust Collector

Reverse-pulse dust collectors are covered in a separate manual. Refer to Section 1.1.1.

## 7.0 SERVICE MAINTENANCE

### 7.1 Gloves

**7.1.1** Special static-dissipating gloves are provided for operator comfort. It will be necessary to change gloves periodically as they wear. The first sign of deterioration may be excessive static shocks.

**7.1.2 Band-clamp type:** Band-clamp type gloves are held in place by metal band-clamps on the inside of the cabinet. To replace, loosen the clamps with a screwdriver, replace the gloves, and tighten the clamps.

**7.1.3 Quick-Change type, clampless installation:** Quick-change gloves are held in place using spring rings sewn into to the attachment end of the glove. To install, insert the glove into the arm port, so one spring is on the inside of the port and the other is on the outside, sandwiching the arm port between both spring rings.

### 7.2 BNP Gun Assembly, Figure 20

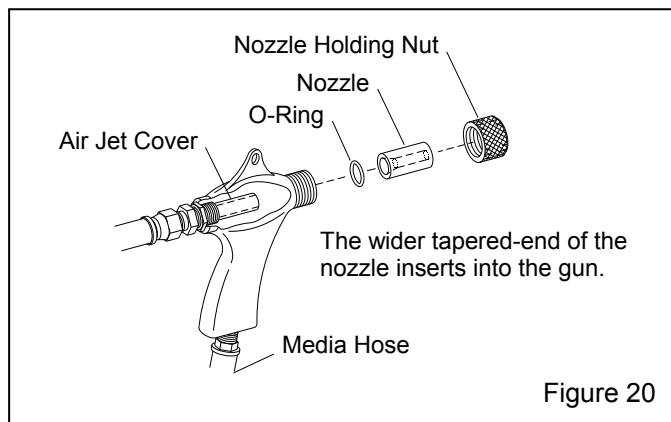

**7.2.1** Replace the nozzle when its diameter has increased by 1/16", or when suction diminishes noticeably. To change the nozzle, unscrew the holding nut from the gun end, and pull the nozzle from the gun. Inspect the nozzle and o-ring and replace if worn or damaged. Inspect the air jet cover replacing it before it wears through will prolong the life of the jet. Insert a new o-ring and nozzle, placing the tapered end of the nozzle toward the jet. Screw the holding nut onto the gun.

### 7.3 View Window Cover Lens

**7.3.1** Rapid frosting of the view window can be avoided by directing ricocheting media away from the window, and by installing a cover lens on the inside surface of the window. Using cover lenses prolongs the life of the view window.

**7.3.2** The best way to install a cover lens is to remove the window from the cabinet. If, for some reason, it is not practical to remove the window, the lens may be applied with the window glass in place.

**7.3.3** To install a cover lens, carefully remove the adhesive backing making sure the adhesive remains on the lens, and apply the lens to the clean, dry, inner surface of the view window. When the cover lens becomes pitted or frosted, replace it.

### 7.4 View Window Replacement

## **⚠ WARNING**

**Do not use plate glass for replacement view windows. Plate glass shatters on impact and could cause severe injury. Use only genuine ZERO® laminated replacement glass.**

**7.4.1** Remove the two window frame nuts located on the upper edge of the window frame, and swing the window frame open. If the frame is to remain open, for cleaning or other reasons, remove it per Section 7.6.

**7.4.2** Remove the old window.

**7.4.3** Inspect the window frame gaskets, both on the window frame and on the cabinet. If either gasket is damaged, replace it per section 7.5.

**7.4.4** Install a view window cover lens per Section 7.3.

**7.4.5** Set the new window (cover lens down) squarely over the window opening, making sure that all edges of the window are centered and overlapping the window gasket, and that the window is resting on the window support tabs.

**7.4.6** Swing the window frame into place and tighten the frame nuts.

### 7.5 Window Gasket Replacement, Figure 21

**7.5.1** Inspect the gaskets when changing the view window. Replace the window frame gasket and cabinet window opening gasket at the first sign of media leakage around the view window, or if gaskets are worn or otherwise damaged.

**7.5.2** Remove the window and window frame per Section 7.6.

**7.5.3** Remove all the old gasket material and clean the surfaces of the cabinet and window frame.

**7.5.4** Peel a short section of adhesive backing from the 5/16"-thick strip gasket, and adhere the gasket to the center of the top edge of the window opening, as shown in Figure 21. Peel additional backing as needed, and



work the strip around the radius of each corner, pressing it firmly to bond. Trim the gasket to fit and compress the ends to seal.

**7.5.5** Using 5/32"-thick strip gasket, repeat the process on the window frame.

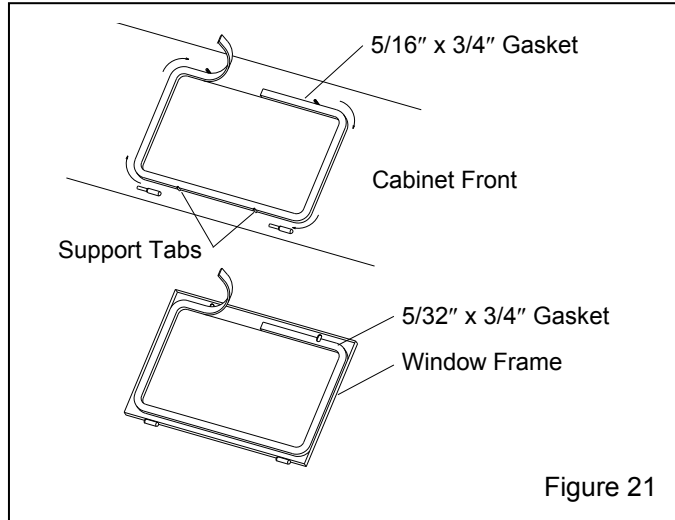

Figure 21

**7.5.6** Trim around the window frame bolt slots, as needed.

**7.6 Window Frame Removal, Figure 22**

**7.6.1** Remove the two window frame nuts located on the upper edge of the window frame, and swing the window frame open.

**7.6.2** Remove the window to prevent breakage.

**7.6.3** Pivot the window frame up or down until tension is off the frame hinges.

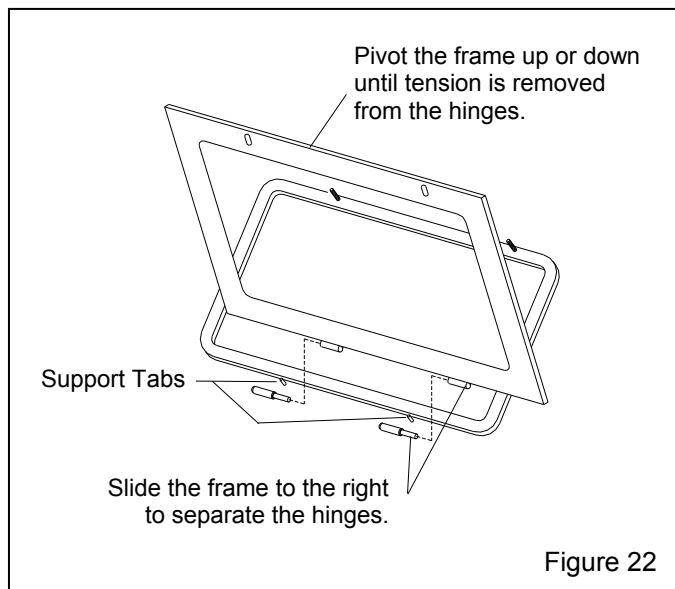

Figure 22

**7.6.4** To remove, slide the frame to the right. The hinges separate as shown in Figure 22.

**7.6.5** Replace the frame in reverse order. Align the top bolt holes with the bolts; slide the frame as necessary.

**7.6.6** Set the window squarely over the window opening, making sure that all edges of the window are centered and overlapping the window gasket, and that the window is resting on the window support tabs.

**7.6.7** Swing the window frame into place and tighten the frame nuts.

**7.7 Light Assembly**

**NOTICE**

**Use an approved step ladder when servicing the light assembly. Do not climb on top of the cabinet. The cabinet top will not support the weight of a person.**

**7.7.1** Shut OFF electrical power.

**7.7.2 Gasket Replacement**

**7.7.2.1** Remove the four wing nuts holding the light fixture to the cabinet, and use the handles to lift the fixture off the cabinet, as shown in Figure 23.

**7.7.2.2** Remove all the old gasket material and clean the surfaces of the cabinet.

**7.7.2.3** Lay a section of strip gasket next to the opening, and cut to length, allowing 3/4" overlap on each end. Peel a short section of adhesive backing and adhere the strip gasket to the top edge of the light opening, as shown in Figure 23. Press the gasket firmly to bond. Repeat the process for each side, compressing the ends to seal.

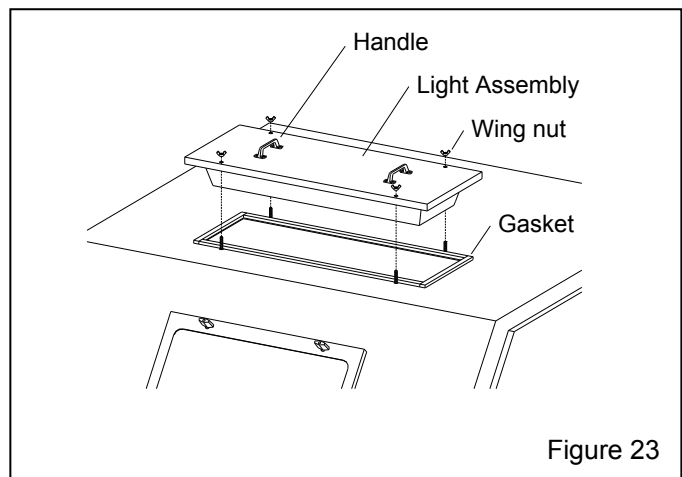

Figure 23

### 7.7.3 Lens and Tube Replacement

**7.7.3.1** Remove the four wing nuts holding the light fixture to the cabinet.

**7.7.3.2** Flip the fixture over to access the lens screws, refer to Figure 24.

**7.7.3.3** Remove the four lens screws and remove lens.

**7.7.3.4** Replace the lens or tubes as required.

**7.7.3.5** Inspect the gasket, and replace if worn or damaged.

**7.7.3.6** Reassemble in reverse order.

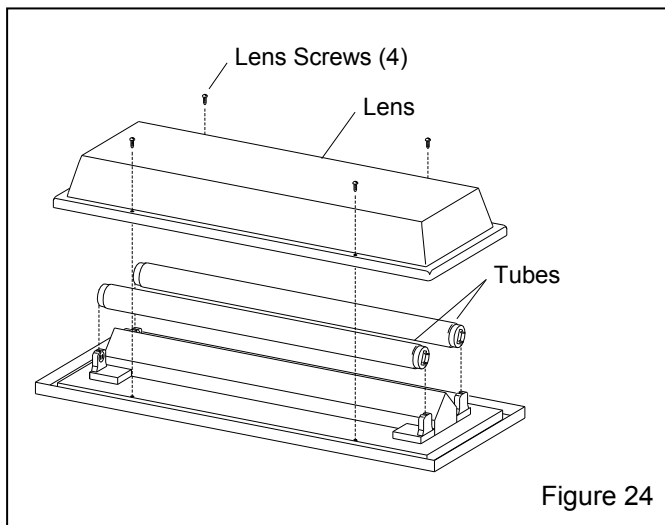

Figure 24

### 7.8 Reclaimer Wear Plate Replacement

**7.8.1** Remove the reclaimer inlet adaptor and old wear plate. The wear plate is held in place by screws attached from the outside of the reclaimer; remove the screws and pull out the wear plate from the reclaimer inlet.

**7.8.2** Angle the new wear plate into reclaimer inlet until it is in position with the straight end at the reclaimer inlet. Using a board or similar object as leverage, pry the wear plate against the inner wall of the reclaimer. While forcing the wear plate against the reclaimer wall, install sheet metal screws through the old screw holes to secure. Caulk seams between the wear plate and reclaimer to prevent rapid wear in those areas.

**7.9 Replacing or Field Installing Optional Reclaimer Rubber Liners, Figure 25.** The reclaimer must be designed to accept liners and have a removable top.

**7.9.1** Remove the flex hoses from the reclaimer inlet and outlet.

**7.9.2** Remove the bolts and nuts securing the reclaimer top, and then remove the top.

**7.9.3** If the reclaimer is currently unlined, proceed to the installation note preceding Paragraph 7.9.11.

**7.9.4** Remove the top liner and tube liner.

**7.9.5** Grind the tack welds from the bottom of the tube liner that secures the tube liner to the tube, then slide the liner off the inner tube.

**7.9.6** Remove the bolts located along the side of the inlet, and remove the inlet baffle.

**7.9.7** To remove the inlet-top liner, remove the self-drilling screws securing it to the top of the inlet.

**7.9.8** Wall liner and inlet-side liner are held in place with self-drilling screws. From the outside of the reclaimer, remove the screws, and remove the liner.

**7.9.9** Inner cone liners and cone-ring liners are glued onto the inner cone. Pull off the liners to remove them.

**7.9.10** Remove old caulking and adhesive from the weldment.

**Installation NOTE:** The numbers in parentheses (-) shown in Figure 25 and the applicable paragraphs, show the recommended order of installation. When installing the liners, make sure that seams are aligned. The final assembly must be smooth and free of protrusions, edges, and gaps. Any edges will disrupt the air flow, causing wear, and affect the reclaimer's media cleaning efficiency.

**7.9.11** (1st) Place the cone-ring liner on the inside of the cone-ring; check fit and trim if needed. Apply medium-set contact cement to the fabric side and install the liner. NOTE: Follow the instructions provided with the adhesive, some adhesives require covering both surfaces to be cemented. Smooth out the liner to eliminate air pockets.

**7.9.12** (2nd) Place the cone liner in the cone with the fabric side down, and check the fit, trim if necessary. Apply medium-set contact cement to the fabric side and install the liner. NOTE: Follow the instructions provided with the adhesive. Some adhesives require it to be

applied to both contact surfaces. Smooth out the liner to eliminate air pockets.

**7.9.13** (3<sup>rd</sup>) Position the inlet-side liner and inlet-top liner to make sure they fit; trimming is occasionally required. Align the inlet-side liner and inlet-top liner and clamp them in place. Use a self-drilling screw at each hole location in the weldment to secure replacement liners. NOTE: To field install new, first-time inlet-side liner and inlet-top liners, after clamping the liners, use self-drilling screws at each liner corner to secure them.

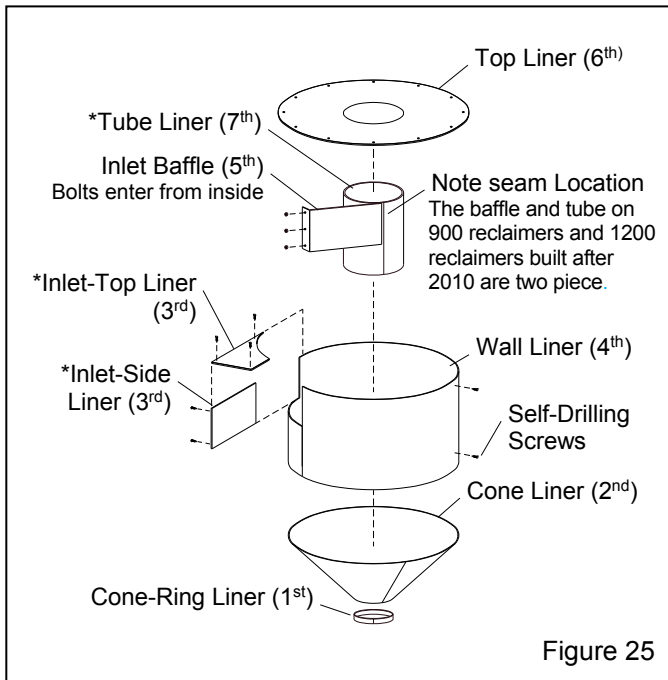

**7.9.14** (4<sup>th</sup>) Clamp the wall liner in place, making sure it is flush with the top of the reclaimer body and the cutout is aligned with the reclaimer inlet. Mark the wall liner at the three bolt-hole locations for the inlet baffle. Remove the liner and drill the bolt holes. Reinstall the wall liner. Align the three bolt holes and temporarily place bolts through the holes to hold it in place. Clamp the liner, and while pushing the liner against the weldment, secure replacement liners, with self-drilling screws at each existing hole location. NOTE: To field install a new, first-time wall liner, use self-drilling screws to secure it at the seam and an inch or two from the top and bottom at each quadrant. Remove the temporary inlet baffle bolts after the liner is secured.

**7.9.15** Apply silicone caulking to seal seams around the inlet-side liner and reclaimer weldment, and between the inlet-top liner and wall liner seam. Apply caulking at the seams of the cone-ring liner and cone liner and between the cone liner and wall liner. Wipe the caulking smooth.

## NOTICE

**All seams between each liner must be sealed, and all seams between the liners and reclaimer weldment must be sealed. Voids will cause premature wear.**

**7.9.16** (5<sup>th</sup>) Apply adhesive-backed strip gasket to the edge of the inlet baffle that will fit against the inner tube. Install the inlet baffle; bolts should be installed from the inside of the reclaimer to attach nuts from the outside.

**7.9.17** (6<sup>th</sup>) Slide the top liner over the inner tube and align the holes in the liner with those in the top. Note that the holes around the inlet are spaced differently from the others. Temporarily install a couple of bolts to keep the alignment.

**7.9.18** (7<sup>th</sup>) Place the tube liner over the inner tube, and use worm clamps to temporarily clamp the liner to the tube. Align it so the seam is on the backside of the baffle, as shown in Figure 25. Make sure the tube liner is tight against the top liner, then tack it to the bottom of the inner tube in three or four places. Remove the clamps when the tube liner is secured.

**7.9.19** Apply caulking to the seam on the tube liner, and between the tube liner and top liner.

**7.9.20** Apply caulking around the top edge of the wall liner and inlet-top liner.

**7.9.21** Align the reclaimer top assembly and lower it into place being careful not to smear the caulking. Secure the top bolts and inlet baffle bolts.

**7.9.22** Working through the reclaimer inlet, wipe the caulking seal smooth. Apply additional caulking to the seam between the baffle and wall liner. Re-caulk any voids.

**7.9.23** Install flex hoses.

**7.9.24** Allow time for the caulking to cure before putting the reclaimer in service.

### 7.10 Reverse-Pulse Dust Collector

Refer to the reverse-pulse dust collector manual as shown on Page 1, Paragraph 1.1.1 for dust collector maintenance.

---

## 8.0 TROUBLESHOOTING

---

### WARNING

---

To avoid serious injury, observe the following when troubleshooting.

- Turn OFF the compressed air supply, bleed the supply line and lockout and tagout the air supply.
  - If checking the controls requires air, always enlist the aid of another person to:
    - Hold the blast gun securely.
    - Operate the foot pedal.
  - Never bypass the foot pedal or wedge it in the operating position.
  - Never bypass the door interlock system.
- 

### 8.1 Poor visibility

**8.1.1** Dirty filter cartridge(s) Pulse cartridge and empty dust container regularly. When using an RPC or RPH, refer to the reverse-pulse dust collector manual to adjust pulse pressure and pulse sequence.

**8.1.2** Exhauster motor not operating. Check voltage to motor and motor wiring.

**8.1.3** Check rotation of exhauster motor; the motor should rotate as indicated by the arrow on the housing. If it does not rotate in the proper direction, **lockout and tagout power** and switch the motor leads as shown on the motor plate. Refer to Section 2.5.

**8.1.4** Using friable media that rapidly breaks down, or using media that is too fine or worn out.

**8.1.5** Dust collector ventilation-damper closed too far restricting air movement through the cabinet. Adjust static pressure per Section 5.4.

**8.1.6** Cabinet air-inlet damper closed too far restricting air movement through the cabinet. Adjust damper per Section 2.6 and 5.6.

**8.1.7** Reclaimer door open.

**8.1.8** Hole worn in flex hose between cabinet hoppers and reclaimer inlet or between the reclaimer and dust collector. Replace hose and route it with as few bends as possible to prevent wear.

**8.1.9** Obstruction in flex hose between the cabinet hoppers and reclaimer inlet.

### 8.2 Abnormally high media consumption

**8.2.1** Door on reclaimer open or worn door gasket. Air entering the reclaimer around the door will cause media carryover to the dust collector. DO NOT operate unless all doors are closed.

**8.2.2** Dust collector ventilation-damper open too far. Adjust static pressure per Section 5.4.

**8.2.3** Media may be too fine or worn-out.

**8.2.4** Using friable media that rapidly breaks down.

**8.2.5** Blast pressure too high for the media, causing media to break down.

**8.2.6** Hole worn in reclaimer, or leak in reclaimer seams. Check entire reclaimer for negative-pressure leaks.

**8.2.7** If using media finer than 180-mesh, the inlet baffle of the reclaimer may need to be removed. Refer to Section 1.8.6.

**8.2.8** Optional externally-adjustable vortex cylinder out of adjustment. Adjust per Section 5.5.

### 8.3 Reduction in blast cleaning rate

**8.3.1** Low media level reducing media flow. Check media level and replenish or replace as needed.

**8.3.2** Media/air mixture out of adjustment. Adjust metering valve per Section 5.3.

**8.3.3** Reduced air pressure. This may be caused by a malfunctioning regulator, a dirty filter element in the air filter, partially-closed air valve, leaking air line, or other air tools in use.

**8.3.4** Blockage in media hose or gun. Blockage may occur as a result of a damaged or missing reclaimer screen or incorrect metering valve adjustment permitting heavy media flow. Adjust metering valve per Section 5.3.

**8.3.5** Worn gun parts such as nozzle or air jet. Inspect and replace all worn parts.

**8.3.6** Worn media hose. Check hose for leaks and soft spots. Replace worn or damaged hose.

**8.3.7** Air jet in gun out of adjustment. Check adjustment per Section 5.2.

**8.3.8** Moist media. Frequent bridging or blockage in the area of the metering valve can be caused by moisture. Refer to Section 8.5.

**8.4 Plugged nozzle**

**8.4.1** A damaged or missing reclaimer screen will allow large particles to pass and block the nozzle. Replace or reinstall as necessary.

**8.4.2** Media mixture too rich. Adjust media/air mixture per Section 5.3.

**8.5 Media bridging**

**8.5.1** Frequent bridging or blockage in the media metering valve can be caused by damp media. Media becomes damp by blasting parts that are slightly oily, from moisture in the compressed-air line, or from absorption from ambient air.

**8.5.2** To avoid contaminating media from the workpiece, all parts put into the cabinet should be clean and dry. If parts are oily or greasy, degrease and dry them prior to blasting.

**8.5.3** Moist compressed air may be due to a faulty compressor, too long an air line permitting moisture to condense on the inside, and from high humidity. Drain the air filter and receiver tank regularly. Ongoing problems with moist air may require the installation of an air dryer or aftercooler in the air supply line.

**8.5.4** Absorption. Some media types tend to absorb moisture from the air, especially fine-mesh media in areas of high humidity. Empty the media and store it in an airtight container when cabinet is not in use.

**8.5.5** A vibrator attached to the reclaimer cone or media metering valve may help to prevent bridging of fine-mesh media. NOTE: To avoid the possibility of compressing media, a vibrator should be setup to start only when the foot pedal is pressed.

**8.6 Blasting does not begin when the foot pedal is pressed.**

**8.6.1** Door interlocks not engaging. Check adjustment per Section 5.7.

**8.6.2** Blocked or leaking control lines. Check all urethane tubing for blockage or leaks.

**8.6.3** Foot pedal valve malfunction. Check foot pedal alignment, and inlet and outlet lines for pressure.

**8.6.4** Make sure lines are not reversed on the foot pedal or pilot regulator. Refer to the schematic in Section 9.10, Figure 38.

**8.6.5** Pressure regulator may be set too low or OFF. Check pressure on pilot regulator.

**8.6.6** Make sure that the air compressor is operating and air supply valves are open.

**8.6.7** Check the nozzle to see if it is plugged. Refer to Section 8.4.

**8.7 Blasting continues after the foot pedal is released**

**8.7.1** Make sure the 3-way valve in the foot pedal exhausts air when the pedal is released. If it does not exhaust, check the inbound air line for blockage, if no blockage, replace the valve.

**8.8 Blockage in media hose**

**8.8.1** Media obstructions. Usually caused when media mixture is too rich. Adjust media/air mixture per Section 5.3.

**8.8.2** Wet or damp media. Refer to Section 8.5.

**8.9 Media surge**

**8.9.1** Heavy media flow. Adjust per Section 5.3.

**8.10 Poor suction in media hose**

**8.10.1** Inadequate air supply. Refer to the tables in Paragraphs 1.9.1 and 2.3.2 and make sure cfm and air hose requirements are met.

**8.10.2** Air jet needs adjustment. Check adjustment per Section 5.2.

**8.10.3** Nozzle is worn. Replace if worn 1/16" or more.

**8.10.4** Blockage in media hose or nozzle. Refer to Sections 8.4 and 8.8.

**8.10.5** Air jet and nozzle combination may be wrong. Refer to the table in Paragraph 1.9.1.

**8.10.6** Air jet sleeve extends past end of air jet. Cut the sleeve to align with the air jet.

**8.10.7** Blast pressure too high, refer to Section 5.1.

**8.10.8** Nozzle inserted backward; the wider, tapered end of the nozzle inserts into the gun toward the air jet.

**8.11 Air only (no abrasive) from nozzle**

**8.11.1** Low media level in reclaimer. Check media level and replenish as needed.

**8.11.2** Make sure the air hose and media hose are not reversed; the green air hose attaches to the back of the gun and the clear media hose attaches to the bottom of the gun's grip. Refer to Section 9.4, Figure 32.

**8.12 Blow-back through media hose**

**8.12.1** Blockage in nozzle. Remove the nozzle and check for blockage.

**8.12.2** Air jet may be too large for nozzle. Refer to the table in Paragraph 1.9.1.

**8.12.3** Blast pressure too high, refer to Section 5.1

**8.13 Media buildup in cabinet hopper, does not convey to reclaimer**

**NOTE Do not pour media directly into the cabinet hopper, as overfilling may occur.** Overfilling will result in media carryover to the dust collector and possible blockage in the conveying hose.

**8.13.1** Exhauster motor rotating backwards. The motor should rotate as indicated by the arrow on the exhauster housing. If it does not rotate in the proper direction, **lockout** and **tagout** electrical power and switch the motor leads as shown on the motor plate. Refer to the system's wiring schematic. Refer to Section 2.5.

**8.13.2** Dust collector ventilation-damper closed too far restricting air movement through cabinet. Adjust static pressure per Section 5.4.

**8.13.3** Dust collector filter cartridge(s) blinded. Refer to the dust collector owner's manual.

**8.13.4** Hole worn in flex hose between cabinet hopper and reclaimer inlet or between the reclaimer outlet and dust collector inlet. Replace hoses and route them with as few bends as possible to prevent wear.

**8.13.5** Reclaimer door open. DO NOT operate unless door is closed.

**8.13.6** Obstruction flex hose. Remove hoses and check for blockage.

**8.14 Static shocks**

**8.14.1** Cabinet and/or operator not grounded. Abrasive blasting generates static electricity. The cabinet must be earth-grounded to prevent static buildup. Refer to Sections 2.2.1 and 2.4. If shocks persist, the operator may be building up static. Attach a small ground wire, such as a wrist strap, from the operator to the cabinet.

**8.14.2** Gloves wearing thin. Inspect gloves and replace them as needed.

**8.14.3** Avoid holding parts off the grate. Static will build-up in the part if not dissipated through the metal cabinet.

**8.15 Dust leaking from cabinet**

**8.15.1** Refer to Section 8.13.

**8.16 Dust leaking from dust collector**

**8.16.1** Damaged or loose filter cartridge(s). Inspect filters, replace as needed.

**8.16.2** Refer to the dust collector owner's manual for operation of the dust collector.

---

9.0 ACCESSORIES AND REPLACEMENT PARTS

9.1 Optional Accessories

Conversion Kits, push-thru reclaimer to pull-thru

Description	Stock No.
To convert from dry filter to CDC-1 dust collector Kit includes outlet adaptor pipe, gasket, and fasteners. For 900 cfm reclaimer .....	28964
To convert from dry filter to RPC or RPH dust collector. Kit includes pull-thru adjustable vortex, gasket, and fasteners. For 900 cfm reclaimer .....	28630

Turntables and Turntables with Tracks

**⚠ WARNING**

**Turntable capacities are based on concentric loading. Use solid fixturing to hold heavy parts in place. Do not remove lift equipment until the part is adequately supported to prevent movement. Moving or rotating heavy, unsupported or off-centered parts may cause them to shift or topple, and cause severe injury.**

Fixed-base Turntable without Bearing

20" dia. 25 lb. capacity .....	12412
--------------------------------	-------

Fixed-base Turntable with Bearing, 500 lb. Capacity  
Figure 26

Item	Description	Stock No.
(-)	20" dia. assembly, 500 lb. capacity .....	12411
(-)	30" dia., assembly 500 lb. capacity .....	14138
1.	Turntable 20" diameter 500 lb. capacity .....	18329
	30" diameter 500 lb. capacity .....	21390
2.	Bearing, 1-1/2" bore .....	11517
3.	Protector, bearing .....	13479
4.	Screw, 1/2-NC x 1-1/2" cap .....	03454
5.	Washer, 1/2" lock .....	03516
6.	Nut, 1/2-NC hex .....	03511

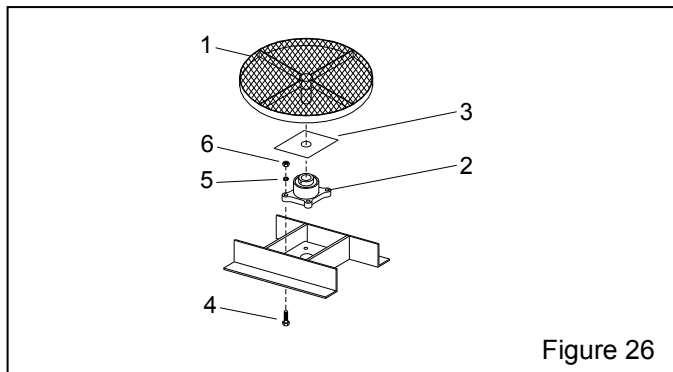

Figure 26

Turntable with Workcar and Track, 500 lb. Capacity

Description	Stock No.
20" diameter turntable and 8-ft. track extension for double 65 .....	13899
for double 220 .....	21199

Turntable with Workcar, 500 lb. Capacity, Figure 27

Item	Description	Stock No.
(-)	Turntable & workcar assembly replacement 20" diameter .....	24205
1.	Turntable replacement, 20" diameter .....	18329
2.	Bearing, 1-1/2" bore .....	11517
3.	Protector, bearing .....	13479
4.	Screw, 1/2-NC x 1-1/2" cap .....	03454
5.	Washer, 1/2" lock .....	03516
6.	Nut, 1/2-NC hex .....	03511
7.	Caster, 4" V groove .....	11594

All other track items are special order. Contact distributor for price and availability.

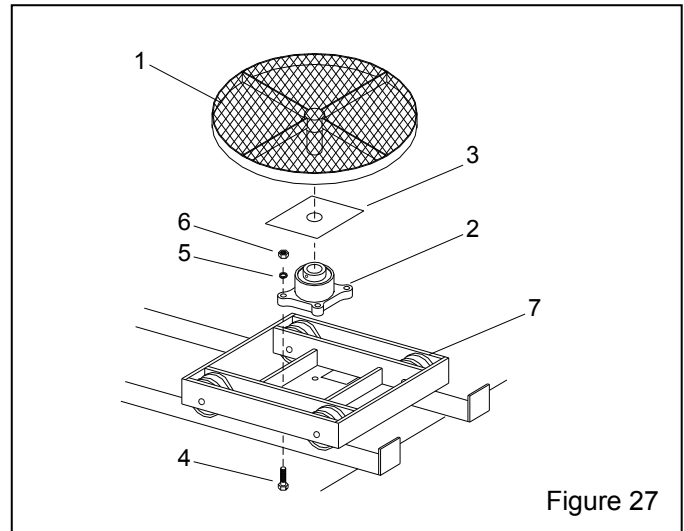

Figure 27

Time delay door locks, BNP double cabinet .....	25558
Tumble basket, 2-gallon, door mounted .....	12227
Lock pins (pkg of 25) for twist-on hose couplings ..	11203
Manometer kit .....	12528
Noise-reduction arm port covers, pair .....	24885
Armrest assembly w/brackets (for one station).....	24900
Armrest assembly, replacement .....	24899
Anti-fatigue floor-mat, for front of cabinet .....	24744
Adjusting tool, air jet (orifice) .....	19041

Aluminum oxide kit, factory installed: Includes #5 boron carbide nozzles, black rubber wall curtains with grommets and curtain hardware. Does not include rubber reclaimer liners.

for double 65 with 900 cfm .....	14130
for double 220 with 900 cfm .....	28894

Aluminum oxide kit, field installed: Filed-installed kits consists of the items noted above for factory kits but also include light-lined flex hose. Does not include rubber reclaimer liners.

for double 65 with 900 cfm .....	12945
for double 220 with 900 cfm .....	21196
Rubber curtains, white	
Curtain set	
for double 65 .....	23543
for 220 .....	23544
Rubber curtains, black	
Curtain set	
for double 65 .....	23533
for double 220 .....	23534
Back curtain, 2 required	
for double 65 .....	14243
for double 220 .....	14247
Front curtain, 2 required	
for double 65 .....	14242
for double 220 .....	14246
Door curtain, 2 required	
for double 65 .....	14244
for double 220 .....	14245

Pass-thru door, with 15-inch square cut-out	
Right door	
for BNP 65 .....	23610
for BNP 220 .....	23612
Left door	
for BNP 65 .....	23611
for BNP 220 .....	23613

Flex hose, heavy-lined, for use with steel and heavy usage with aluminum oxide. Available in 15 ft. lengths only

4" ID. for 900 (1200w/steel) cabinet hopper .....	12473
5" ID. for 1200 cfm cabinet hopper .....	12465
6" ID. for 900 (1200w/steel) reclaimer inlet .....	12457
7" ID. for 1200 cfm reclaimer inlet .....	12459

Tungsten carbide nozzle	
No. 5, 5/16" orifice .....	13118
No. 7, 7/16" orifice.....	12882
No. 8, 1/2" orifice .....	11942

Boron carbide nozzle	
No. 5, 5/16" orifice .....	11935
No. 6, 3/8" orifice .....	11936
No. 7, 7/16" orifice .....	11937
No. 8, 1/2" orifice .....	12894

Wide-spray nozzle	
Tungsten carbide	
No. 6, 3/8" orifice .....	11947
Boron carbide	
No. 6, 3/8" orifice .....	11934
No. 8, 1/2" orifice .....	11944

NOTE: Wide-spray nozzles require the following accessories:

Nozzle nut, wide-spray .....	11916
Retaining ring, wide-spray .....	12038
Nozzle guard, wide-spray .....	12295

**Extension Nozzles, Figure 28**

Item	Description	Stock No.
1.	3" Straight extension nozzle	
	No. 5, 5/16" orifice .....	11921
	No. 6, 3/8" orifice .....	11922
	No. 7, 7/16" orifice .....	11923
2.	6" Straight extension nozzle	
	No. 5, 5/16" orifice .....	11927
	No. 6, 3/8" orifice .....	11928
	No. 7, 7/16" orifice .....	11929
3.	9" Straight extension nozzle	
	No. 5, 5/16" orifice .....	11924
	No. 6, 3/8" orifice .....	11925
	No. 7, 7/16" orifice .....	11926
4.	Side-angle extension nozzle assemblies with No. 5 orifice, includes 5, 6, 7, and 8	
	4" long assembly .....	21311
	6" long assembly .....	12374
	9" long assembly .....	12373
5.	Side angle extension nozzle casing	
	4" long casing .....	11943
	6" long casing .....	11940
	9" long casing .....	11939
6.	Tip, side-angle extension .....	12173
7.	Snap ring, side-angle extension .....	12040
8.	O-ring, side-angle extension .....	08977

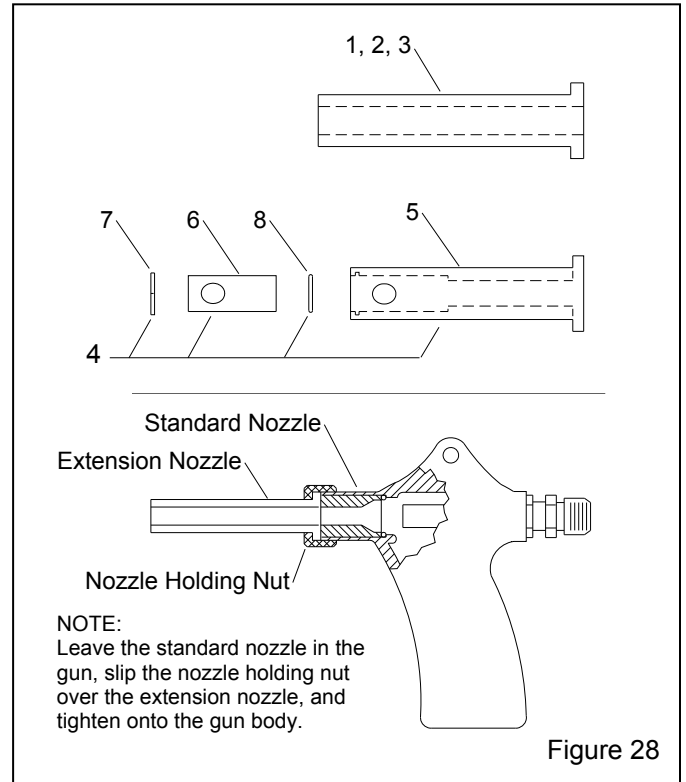

Figure 28



**Reclaimer Liners, Figure 29**

Reclaimer must be designed to accept liners and have a removable top.

Item	Description	Stock No.
(-)	Rubber liner sets	
	900 cfm .....	23151
	1200 cfm .....	25439
1.	Top liner	
	900 cfm .....	23059
	1200 cfm .....	22689
2.	Baffle, lined, 2-pc. includes tube liner	
	900 cfm .....	23416
	1200 cfm .....	24654
3.	Side liner, reclaimer body	
	900 cfm .....	17008
	1200 cfm .....	25436
4.	Inlet side liner	
	900 cfm .....	12830
	1200 cfm .....	22693
5.	Inner cone liner	
	900 cfm .....	16070
	1200 cfm .....	22694
6.	Inlet top	
	900 cfm .....	22827
	1200 cfm .....	24031
7.	Screw, self-drilling, 10-16 x 3/4" .....	12722

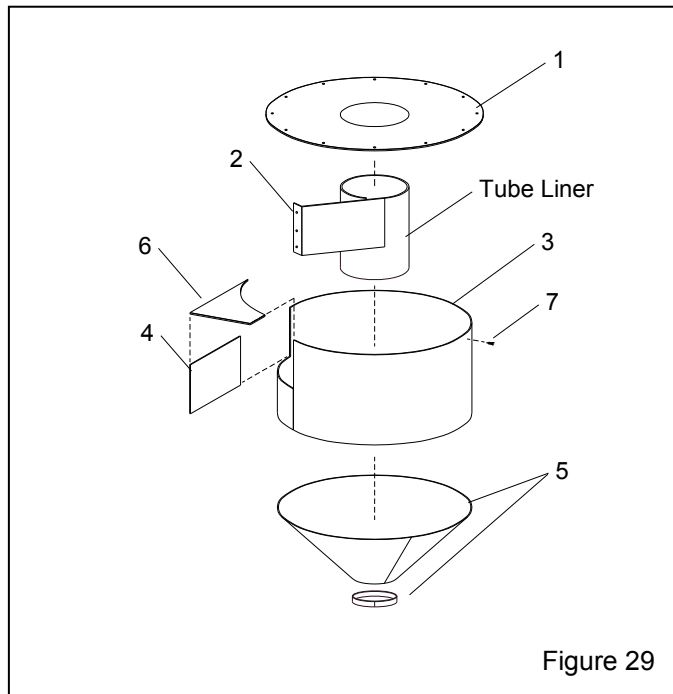

**9.2 Flex Hose & Wye Adaptor, Figure 30**

All hose is sold per foot, specify feet required. Some trimming may be necessary.

Item	Description	Stock No.
1.	Hose, light-lined flex, 5-ft required per side 4" ID for 900 cfm conventional use .....	12466
	4" ID for 1200 cfm w/steel media .....	12466
	5" ID for 1200 cfm conventional use .....	12467
2.	Hose, light-lined flex, 9-ft required 6" ID for 900 cfm conventional use .....	12468
	6" ID for 1200 cfm w/steel media .....	12468
	7" ID for 1200 cfm conventional use .....	12469
3.	Hose, unlined flex, specify feet required 7" ID for 900 cfm .....	12448
	12" ID for 1200 cfm .....	12460
4.	Clamp, hose for 4" hose .....	11577
	for 5" hose .....	11578
	for 6" hose .....	00750
	for 7", 8", and two for 12" hose .....	11576
5.	Wye pipe adaptor, 4" x 4" x 6" 900 cfm conventional 1200 cfm w/steel .....	12379
	5" x 5" x 7", for 1200 cfm conventional ...	16939

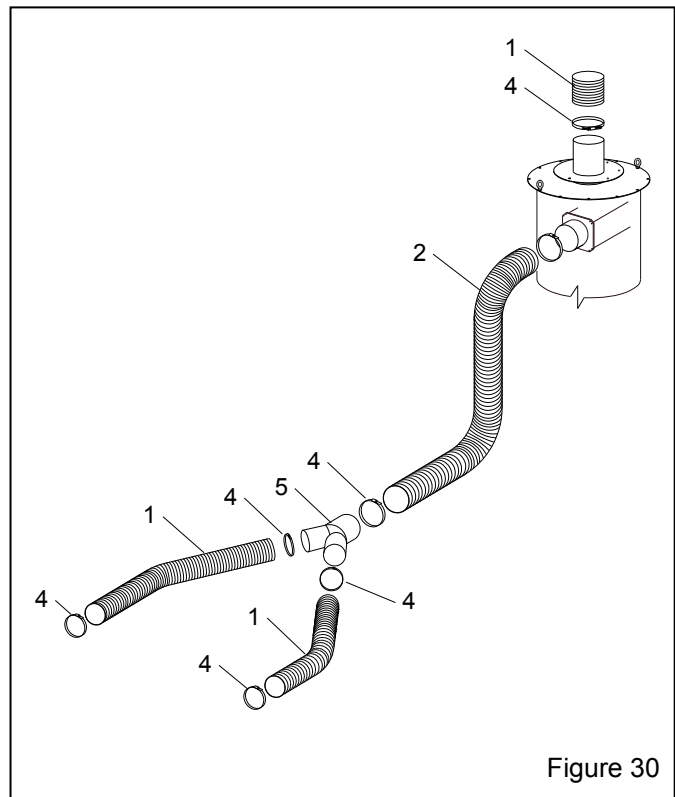

**9.3 Cabinet Replacement Parts, Figure 31**  
**Unless noted, quantity is for each unit**

Item	Description	Stock No.
1.	Gasket, 5/16" x 1" adhesive-backed, per foot, specify feet required BNP 65 door, 11 ft. per door ..... 00187 BNP 220 door, 13 ft. per door ..... 00187 Light assembly, 7 ft. each ..... 00187 Air-inlet damper, 3 ft. each ..... 00187	
2.	Light assembly w/ cover (each)..... 23255	
3.	Door assembly, left for double 65 ..... 20070 for double 220 ..... 20074	
4.	Door assembly, right for double 65 ..... 20071 for double 220 ..... 20075	
5.	Grate for double 65, 2 required ..... 11811 for double 220, 2 required ..... 11810	
6.	Latch kit, door, each ..... 20064	
7.	Glove set Band-clamp attachment ..... 11215 Quick-change (clampless attachment)... 28820	
8.	Glove, left hand only Band-clamp attachment ..... 12710 Quick-change (clampless attachment)... 28638	
9.	Glove, right hand only Band-clamp attachment ..... 12711 Quick-change (clampless attachment)... 28639	
10.	Clamp, for clamp-attached glove ..... 11576	
11.	Grommet, media/air hose ..... 11798	
12.	Plate, hopper hose ..... 21656	
13.	Gasket, hopper plate ..... 20247	
14.	Hose, light-lined flex, 5-ft required per side 4" ID for 900 cfm conventional use ..... 12466 4" ID for 1200 cfm w/steel media ..... 12466 5" ID for 1200 cfm conventional use ..... 12467	
15.	Clamp, flex hose for 4" hose ..... 11577 for 5" hose ..... 11578	
16.	Adaptor pipe universal, flex hose 4" for 900 cfm conventional..... 23295 4" for 1200 cfm w/steel media ..... 23295 5" for 1200 cfm conventional ..... 23296	
17.	Gasket, flex hose adaptor pipe 4" for 900 conventional ..... 23258 4" for 1200 cfm w/steel media ..... 23258 5" for 1200 conventional..... 23259	
18.	Actuator bracket, door interlock ..... 19152	
19.	Detent sleeve, door interlock ..... 15042	
20.	Over-travel stop, door interlock ..... 20004	
21.	Air valve, 3 way, door interlock..... 12202	
22.	Regulator, 1/8" NPT pilot pressure..... 12715	
23.	Gauge, pressure ..... 01908	
24.	Fitting, 1/8" NPT elbow x 1/8" barb ..... 11733	
25.	Grommet, 1/4 ID ..... 12762	
26.	Foot pedal assembly, less tubing ..... 20483	
27.	Damper, air-inlet ..... 23156	
28.	Brace, leg For BNP 65 ..... 24443 For BNP 220 ..... 24445	

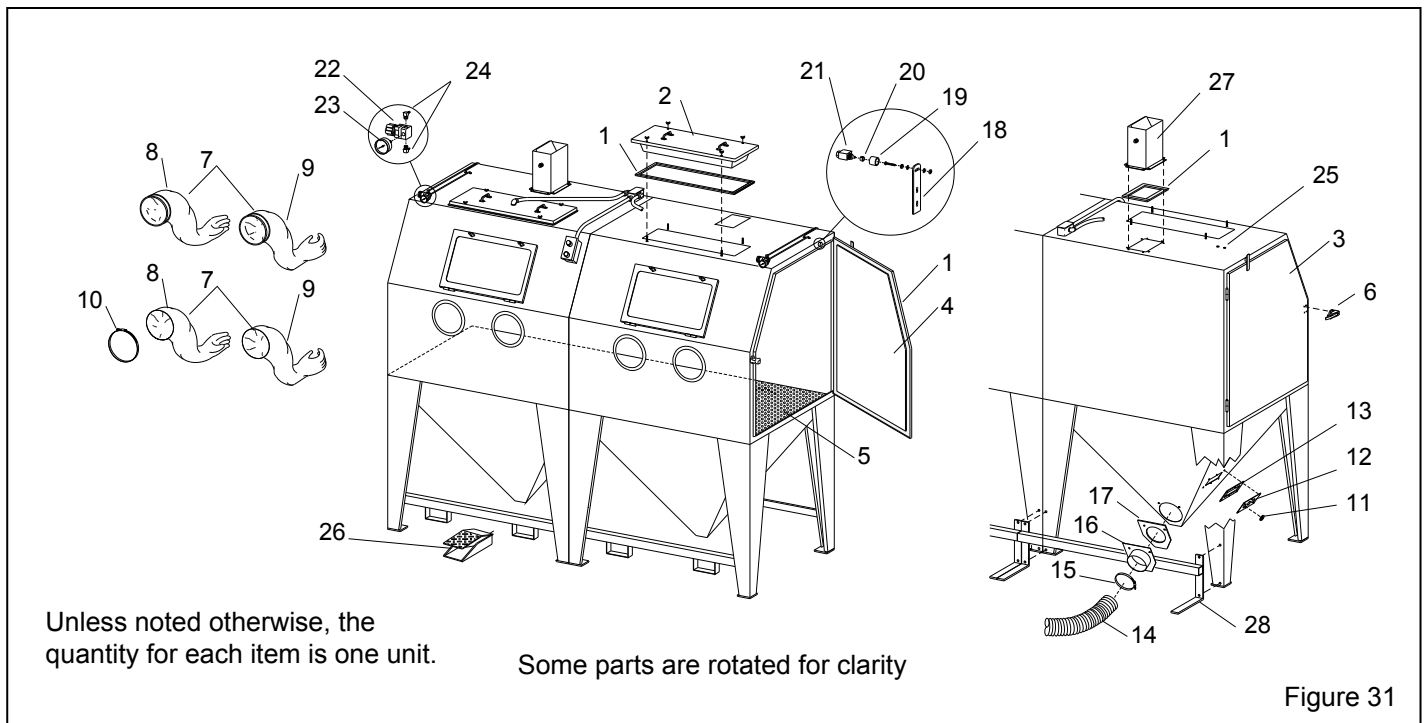
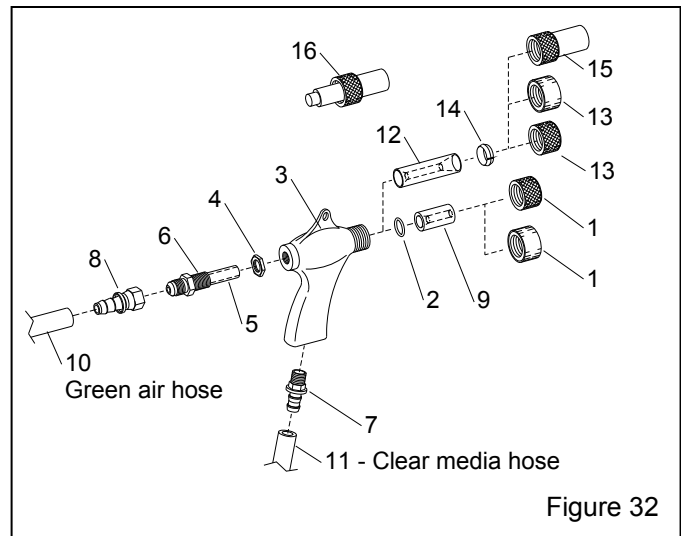

Figure 31

9.4 BNP Gun and Feed Assembly, Figure 32

Item	Description	Stock No.
(-)	BNP Gun assemblies less nozzle, includes items 1 (brass) through 7	
	No. 4 Gun .....	12301
	No. 5 Gun .....	12302
	No. 6 Gun .....	12303
	No. 7 Gun .....	12304
	No. 8 Gun .....	12305
1.	Nut, nozzle holding	
	Standard, knurled brass .....	11914
	Urethane covered .....	11574
2.	O-ring .....	08975
3.	Gun body .....	11802
4.	Lock nut, air jet .....	11913
5.	Rubber sleeve .....	12097
6.	Air jet assembly, includes item 5	
	No. 4 .....	12342
	No. 5 .....	12343
	No. 6 .....	12344
	No. 7 .....	12345
	No. 8 .....	12346
7.	Fitting, hose, 3/8" NPT x 1/2" barb .....	06369
8.	Hose end, 1/2" barb x 1/2" fem. swivel .....	15002
9.	Nozzle, ceramic	
	No. 5 .....	11930
	No. 6 .....	11931
	No. 7 .....	11932
	Nozzle, boron carbide	
	No. 5 .....	11935
	No. 6 .....	11936
	No. 7 .....	11937
	No. 8 .....	12894
	Nozzle, tungsten carbide	
	No. 5 .....	13118
	No. 7 .....	12882
	No. 8 .....	11942
10.	Hose, 1/2" air, specify ft. required .....	12472
11.	Hose, media, clear, specify ft. required .....	12476
12.	Wide-spray nozzle	
	Tungsten carbide, No. 6 .....	11947
	Boron carbide	
	No. 6 .....	11934
	No. 8 .....	11944
13.	Wide-spray nozzle nut	
	Knurled brass .....	11916
	Urethane covered .....	12906
14.	Wide-spray retaining ring .....	12038
15.	Wide-spray nozzle guard .....	12295
16.	Adjusting tool, air jet .....	19041



9.5 Suction Inlet Regulator Assembly, Figure 33

Item	Description	Stock No.
1.	Filter, 1/2" manual drain air .....	01308
2.	Regulator, 1/2" pilot operated pressure ....	11345
3.	Bracket, 1/2" regulator assembly .....	19231
4.	Nipple, 1/2" x 2 .....	01734
5.	Cross, 1/2" NPT .....	10254
6.	Lock nut, 1/2" .....	12713
7.	Bushing, 1/2" NPT x 1/8" .....	11350
8.	Adaptor, 1/2" NPT x 1/2" flare .....	11351
9.	Adaptor, 1/8" NPT x 1/8" barb .....	11732
10.	Bushing, 1/4" NPT x 1/8" brass.....	02010
11.	Hose end, 1/2" barb x 1/2" female swivel ..	15002
12.	Tee, 1/2" NPT .....	01787
13.	Nipple, 1/2" x close .....	01733
14.	Plug 1/2" NPT .....	01759
15.	Screw, 1/2-NC x 1/2 set .....	03471

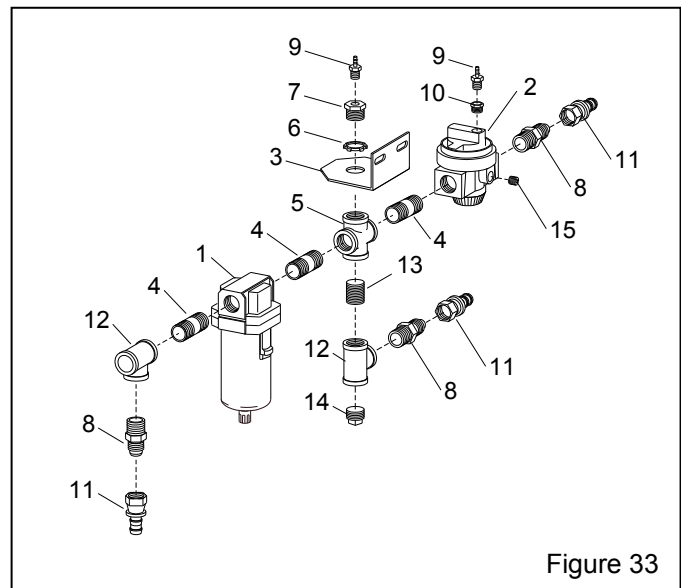

**9.6 Foot Pedal Assembly, Figure 34**

Item	Description	Stock No.
(-)	Foot pedal assembly, less tubing .....	20483
1.	Foot pedal casting set, top and base .....	28379
2.	Valve, 10-32, 3 way n/c .....	20026
3.	Drive pin, grooved .....	20109
4.	Screw, sh 1/4 NF x 3/4" .....	03086
5.	Screw, 10-32 x 1/2" fh .....	19571
6.	Adaptor, 10-32 thrd. x 1/8 barb .....	11731
7.	Spring, 1-1/4" x 3-1/2" .....	20121
8.	Screw, 8-32 x 3/8" thread cutting .....	11389
9.	Bumper, rubber (feet) .....	21522

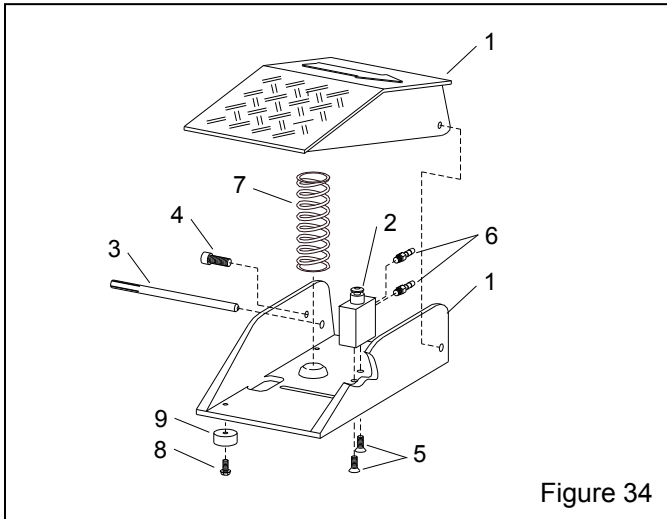

Figure 34

**9.7 Metering Valve Assembly, Figure 35**

Item	Description	Stock No.
(-)	Metering valve assembly, items 2 thru 7 ..	12417
1.	Metering stem assembly .....	23889
2.	Stem, metering adjusting .....	23097
3.	Screw, adjusting .....	23098
4.	Nut, adjusting stem lock .....	23099
5.	Body, metering valve .....	11532
6.	Fitting, hose, 3/8" NPT x 1/2" barb .....	06369
7.	Plug, metering valve .....	12011

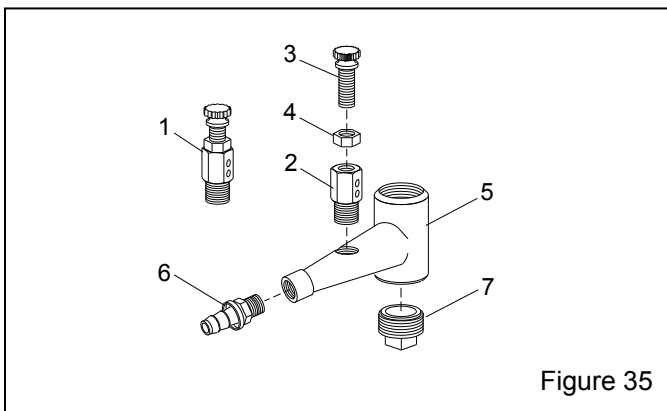

Figure 35

**9.8 Light Assembly, Figure 36**

Item	Description	Stock No.
(-)	Light assembly w/ cover .....	23255
1.	Light fixture (does not include cover or tubes) .....	24740
2.	Reflector lens .....	23253
3.	Tube, fluorescent, 17w .....	24741

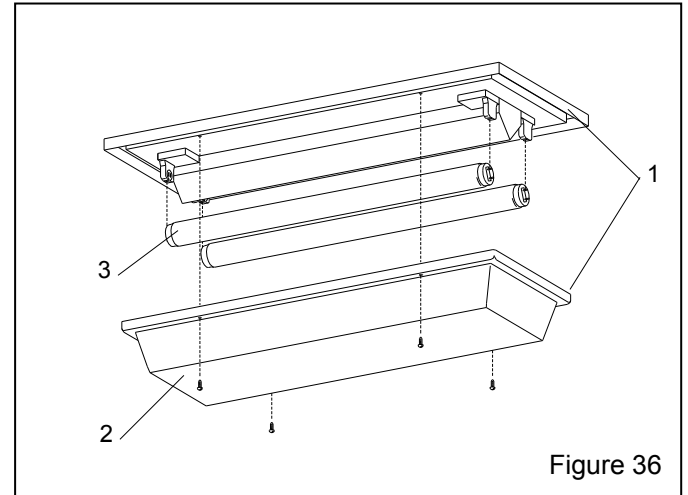

Figure 36

**9.9 View Window Assembly, Figure 37**

Item	Description	Stock No.
1.	Window glass, 12.5" x 19.5" laminated ....	12212
2.	Gasket, 5/16" x 3/4", applied to cabinet per foot, 6-feet required .....	00189
3.	Gasket, 5/32" x 3/4", applied to window frame per foot, 6-feet required .....	00192
4.	Cover lens, pkg. of 5 .....	06190
5.	Nut, plastic, window frame, 2 required on conventional, 4 on ergo ...	23035
6.	Window frame, quick change for conventional model cabinet .....	22826
	for ergo model cabinet .....	25429

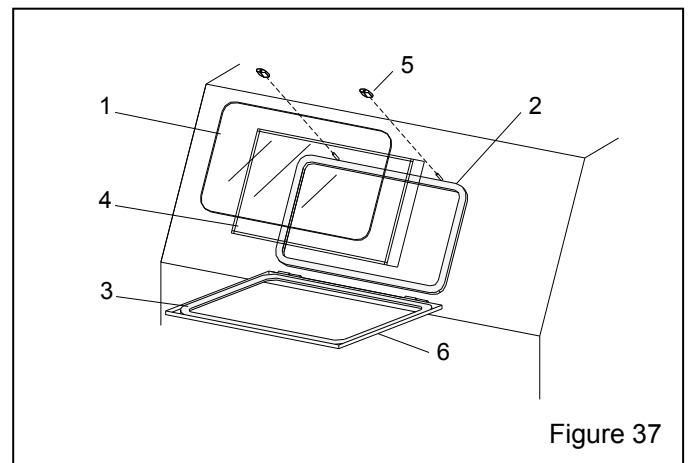

Figure 37

9.10 Cabinet Plumbing Assembly, Figure 38

Item	Description	Stock No.
1.	Valve, 3 way	12202
2.	Adaptor, 1/8" NPT x 1/8" barb	11732
3.	Tubing, 1/8" urethane, specify ft. required	12475
4.	Tubing, twin urethane, specify ft. required	19577
5.	Foot pedal assembly, less tubing	20483
6.	Metering valve	12417
7.	Regulator, 1/8" pilot	12715
8.	Gauge, pressure, 1/8"	01908

9.	Fitting, 1/8" NPT elbow x 1/8" barb	11733
10.	Filter, 1/2" manual drain	01308
11.	Adaptor, 1/2" NPT x 1/2" flare	11351
12.	Hose end, 1/2" barb x 1/2" female swivel	15002
13.	Hose end, 1/2" barb x 3/8" male NPT	06369
14.	Blow-off nozzle	06368
15.	Air hose, 1/2", specify ft. required	12472
16.	Gun assembly, BNP No. 5	12302
17.	Hose, clear urethane, specify ft. required	12476
18.	Regulator, 1/2" pilot operated	11345

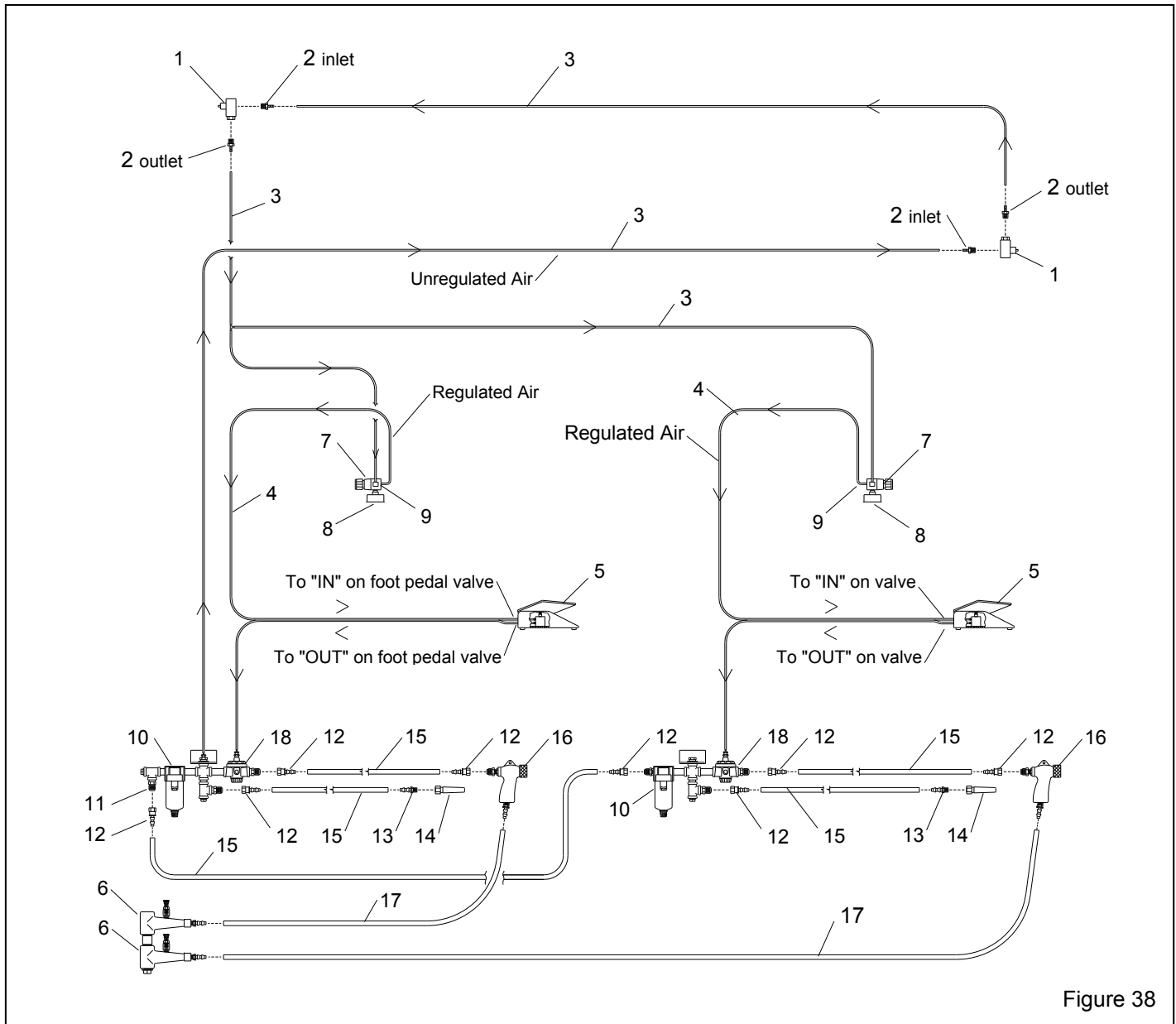

Figure 38

9.11 Reclaimer, Figure 39

Item	Description	Stock No.
(-)	Reclaimer assemblies, pull-thru style	
	900 cfm, w/outlet pipe (no adj. vortex) ....	28967
	900 cfm with adjustable vortex.....	21305
	1200 cfm with adjustable vortex.....	24060
1.	Gasket, 5/16" x 1" adhesive-backed, per foot, five feet required .....	00187
2.	Inlet pipe adaptor, 900 cfm, 6" .....	12363
3.	Gasket, inlet adaptor	
	900 cfm .....	11759
	1200 cfm .....	11767
4.	Wear plate, rubber-lined w/mounting screws 900 cfm	
	reclaimers with solid top .....	14055
	reclaimers with removable top .....	25071
	1200 cfm .....	19223
5.	Screen assembly .....	21265
6.	Gasket, door	
	900 cfm .....	11745
	1200 cfm .....	11766
7.	Door assembly, w/gasket and latch.....	14271
8.	Spring latch assembly .....	12263
9.	Hose support, inlet	
	6", 900 cfm, optional .....	16887
	6", 1200 cfm for steel grit .....	22729
	7", 1200 cfm 7" conventional.....	20596

10.	Vortex cylinder externally adjustable, 900 cfm, option .....	23046
	1200 cfm .....	25432
11.	Adaptor, outlet pipe, 900 cfm .....	16832
12.	Top plate assembly, 900 cfm .....	23040
13.	Gasket, 2" adhesive-backed, per foot, 900= 7 ft., 1200= 8 ft. at each location ...	13089
14.	Eyebolt 3/8-NC .....	00430
15.	Hopper and leg assembly, 900 cfm .....	23042
16.	Body section 900 cfm, w/door & wear plate for reclaimers with bolt-on top only .....	27465
*17.	Body section 900 cfm, with door rubber liners and bolt-on top, .....	27466
*18.	Hose, light-lined flex, 9-ft required	
	6" ID for 900 cfm conventional use .....	12468
	6" ID for 1200 cfm w/steel media .....	12468
	7" ID for 1200 cfm conventional use .....	12469
*19.	Clamp, hose	
	for 6" hose .....	00750
	for 7", 8", and two for 12" hose .....	11576
	for 12" hose, 2 required.....	11576
*20.	Hose support, outlet, optional	
	7" for 900 cfm .....	20619
	12" for 1200 cfm .....	20730
*21.	Hose, unlined flex, specify length required	
	7" ID for 900 cfm .....	12448
	12" ID for 1200 cfm .....	12460

\*These items are not included with replacement reclaimer. Order separately if needed.

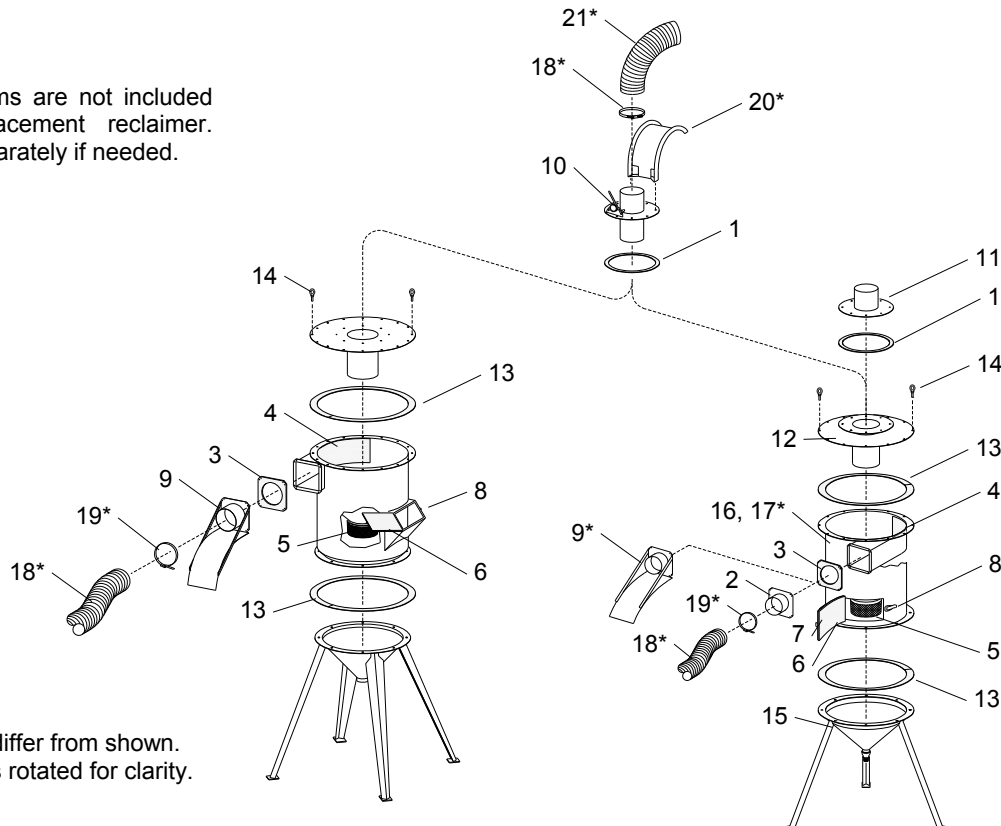

Style may differ from shown. Some parts rotated for clarity.

Figure 39