

BNP 55

Suction Blast Cabinet

O. M. 23350

DATE OF ISSUE: 08/01

REVISION: F, 07/16

NOTICE TO PURCHASERS AND USERS OF OUR PRODUCTS AND THIS INFORMATIONAL MATERIAL

Clemco proudly provides products for the abrasive blast industry and is confident that industry professionals will use their knowledge and expertise for the safe and efficient use of these products.

The products described in this material, and the information relating to these products, are intended for knowledgeable, experienced users. It is the responsibility of the user to insure that proper training of operators has been performed and a safe work environment is provided.

No representation is intended or made as to: the suitability of the products described here for any purpose or application, or to the efficiency, production rate, or useful life of these products. All estimates regarding production rates or finishes are the responsibility of the user and must be derived solely from the user's experience and expertise, not from information contained in this material.

It is possible that the products described in this material may be combined with other products by the user for purposes determined solely by the user. No representations are intended or made as to the suitability of or engineering balance of or compliance with regulations or standard practice of any such combination of products or components the user may employ.

This equipment is only one component of a cabinet blasting operation. Other products, such as air compressors, air filters and receivers, abrasives, equipment for ventilating, dehumidifying, or other equipment, even if offered by Clemco, may have been manufactured or supplied by others. The information Clemco provides is intended to support the products Clemco manufactures. Users must contact each manufacturer and supplier of products used in the blast operation for warnings, information, training, and instruction relating to the proper and safe use of their equipment.

© 2016 CLEMCO INDUSTRIES CORP.

One Cable Car Dr.

Washington, MO 63090

Phone (636) 239-4300

Fax (800) 726-7559

Email: info@clemcoindustries.com

www.clemcoindustries.com



1.0 INTRODUCTION

1.1 Scope of Manual

1.1.1 These instructions cover set-up, operation, maintenance, troubleshooting, optional accessories, and replacement parts for BNP 55 series suction blast cabinets. The instructions covers the operation of all pull-thru reclaimers and the installation of the dust collector. One of the following supplemental manuals is provided with the dust collector, refer to the appropriate manual for operation and maintenance of the collector.

- CDC-1 Dust collectors, manual stock no. ... 28225
- RPC-2 Dust collector, manual stock no.22788
- RPH Dust collectors, manual stock no.21449

1.1.2 These instructions also contain important information required for safe operation of the cabinet. Before using this equipment, all personnel associated with the blast cabinet operation must read this entire manual, and all accessory manuals to become familiar with the operation, parts and terminology.

1.2 Safety Alerts

1.2.1 Clemco uses safety alert signal words, based on ANSI Z535.4-2011, to alert the user of a potentially hazardous situation that may be encountered while operating this equipment. ANSI's definitions of the signal words are as follows:



This is the safety alert symbol. It is used to alert you to potential physical injury hazards. Obey all safety messages that follow this symbol to avoid possible injury or death.

NOTICE

Notice indicates information that is considered important, but not hazard-related, if not avoided, could result in property damage.

CAUTION

Caution indicates a hazardous situation that, if not avoided, could result in minor or moderate injury.

WARNING

Warning indicates a hazardous situation that, if not avoided, could result in death or serious injury.

DANGER

Danger indicates a hazardous situation that, if not avoided, will result in death or serious injury.

1.3 General Description

1.3.1 BNP blast cabinets enclose the blasting environment to provide efficient blasting while maintaining a clean surrounding work area. Production rates are influenced by size of nozzle, compressor output, working pressure, type and size of media, angle and distance of the nozzle from the blast surface. BNP suction cabinets consist of three major components:

1. Cabinet Enclosure
2. Reclaimer
3. Dust Collector

Refer to Figure 1 for arrangement of components with a CDC-1 dust collector. Figure 2 shows the arrangement with a RPC-2 600 cfm (not available in 300 cfm) reverse-pulse dust collector with dust drawer. The optional RPH-2 (600 cfm) is set up the same way as the RPC, but includes a hopper for additional dust storage, and empties into a drum. The overall height of the RPH is approximately 10-feet, 6-inches, and 12-ft when the top access door is open. An upgraded, RPC or RPH collector may be added at any time

1.4 Theory of Operation

1.4.1 Once the components are correctly setup and turned ON, the cabinet is ready for operation by actuation of the foot pedal. Fully depressing the foot pedal causes air to flow through the blast gun. Air moving through the gun draws media into the gun's mixing chamber. The media mixes with the air and is propelled out the nozzle. After striking the object being blasted, the blast media, fines, dust, and by-products generated by blasting, fall through the mesh work table into the cabinet hopper. These particles are then drawn into the reclaimer for separation. Lightweight dust and fines remain airborne and are drawn out to the dust collector. Heavier reusable media fall through the screen into the reclaimer hopper for reuse. The dust collector traps dust and fines and discharges clean air. When the foot pedal is released, blasting stops.

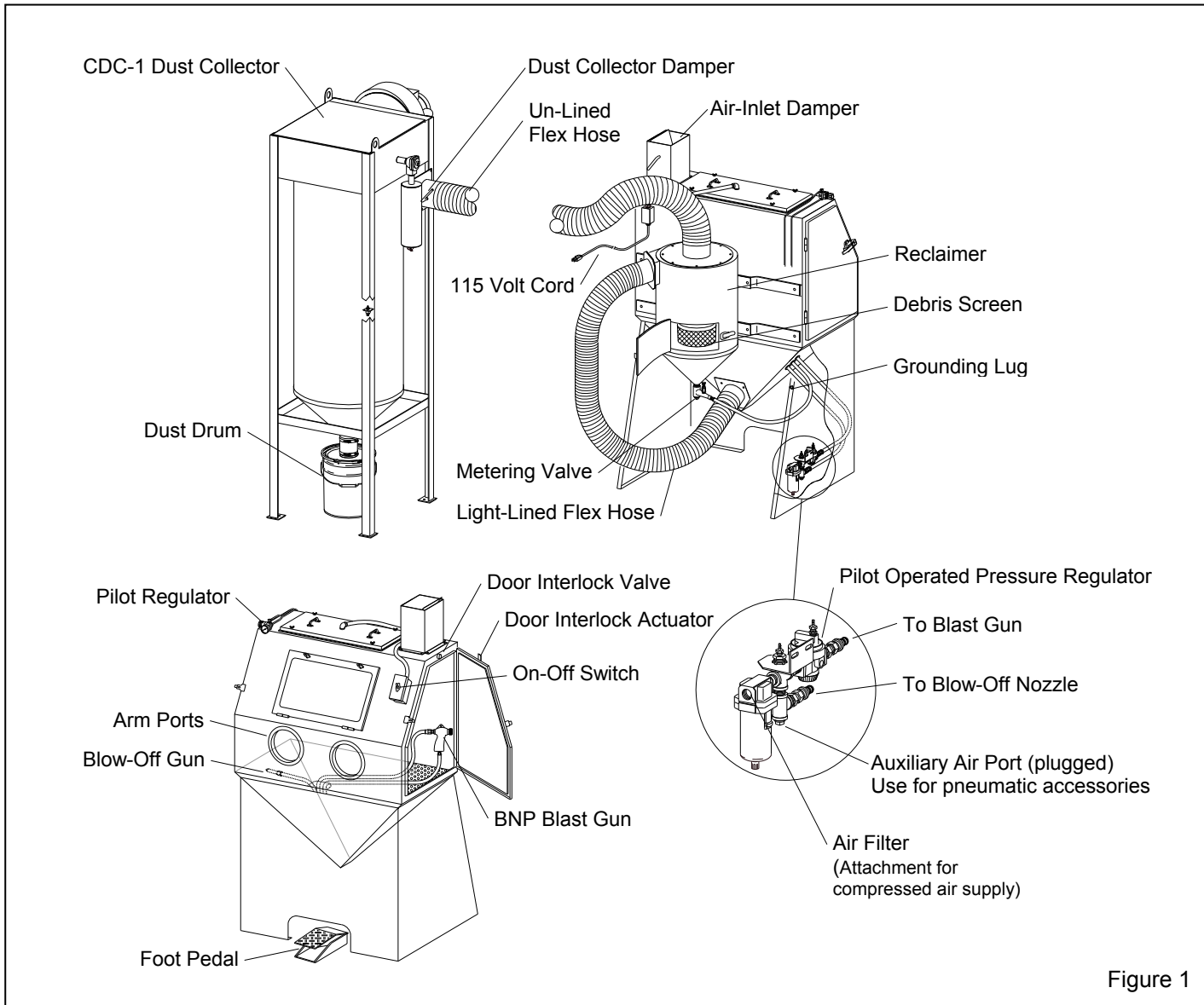

Figure 1

1.5 Reverse-Pulse Dust Collector Options

⚠ WARNING

Prolonged exposure to any dust could result in serious lung disease and death. Short term ingestion of toxic materials, such as lead dust or dust from other heavy metals and corrosives, could cause serious respiratory injury or death. Identify all materials that are to be removed by blasting. Use reverse-pulse dust collectors with HEPA after-filters if lead coating or any other toxic materials are being removed by the blasting process. Do not use dust collectors with simple cloth filters for those applications.

1.5.1 CDC-1 Dust Collectors: Shown in Figure 1, the collector is available in 300 and 600 models. The single filter cartridge is cleaned by using a manually-controlled pulse of compressed air. CDC-1 dust collectors are standard with BNP cabinets unless an optional RPC-2 or RPH dust collector is ordered at time of purchase. Refer to manual number 28225 for operation of the CDC-1 dust collector.

1.5.2 RPC-2 Dust Collectors: Shown in Figure 2, this collector is available in a 600 cfm model. Dual filter cartridges are automatically cleaned by a timed, periodic pulse of compressed air. Dust collects in the draw and must be frequently emptied. Refer to manual number 22788 for operation of the RPC-2 dust collector.

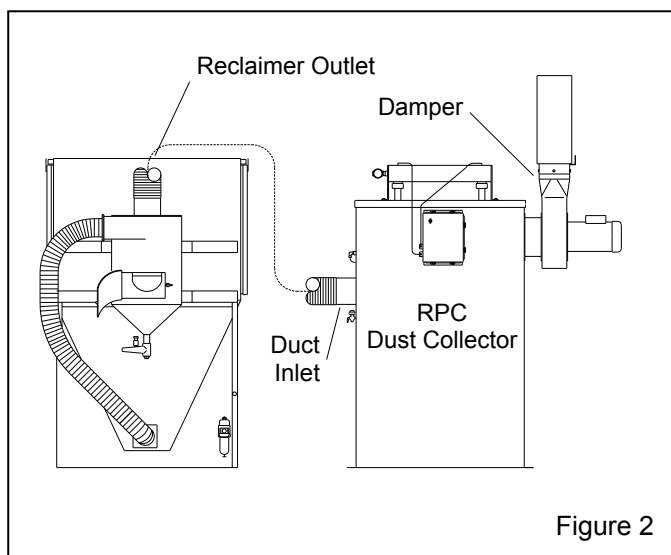

Figure 2

1.5.3 RPH-2 Dust Collector: The RPH-2 is available for in a 600 cfm model. It is set up and operates the same as the RPC-2, as shown in Figure 2, but instead of a dust drawer, the collector sits atop a hopper, which provides additional dust storage, and empties into a drum. Refer to manual number 21449 for operation of the RPH dust collector.

1.5.4 HEPA (high-efficiency particulate air) Filter: HEPA after-filters provide additional filtration and must be used with a reverse-pulse cartridge collectors when removing lead coatings or any other toxic materials.

1.6 Nozzle Options

1.6.1 Unless otherwise specified at the time of order, cabinets are shipped with a 5/16" orifice ceramic nozzle and No. 5 (5/32" orifice) air jet. Optional, more durable tungsten carbide and boron carbide nozzles are available and are shown under replacement parts in Section 9.3. Use a boron carbide nozzle when blasting with aggressive media, as noted in Section 1.8.4.

1.7 Reclaimer Options

1.7.1 Replaceable rubber reclaimer liners: The liners prolong service life of the reclaimer, and should be installed when using silicon carbide, aluminum oxide, or other aggressive media as noted in Section 1.8.4. Rubber liners are available for 600 cfm reclaimers that have a removable top and are designed to accept liners. Rubber liners are shown on Page 22, Figure 26

1.8 Blasting Media

⚠ WARNING

Obtain Safety Data Sheets (SDS) for the blast abrasive. Abrasive blasting with sands containing crystalline (free) silica can lead to serious or fatal respiratory disease. As NIOSH recommends, do not use abrasives containing more than trace amounts (more than one percent) free silica.

NOTE: Use only abrasives specifically manufactured for blast cleaning and are compatible with the surface being blasted. Abrasive produced for other applications may be inconsistent in size and shape, contain particles that could jam the abrasive metering valve, or cause irregular wear.

1.8.1 BNP 55 Suction Blast Cabinets utilize most common reusable media that is specifically manufactured for dry blasting. Recommended media sizes are:

- With 300 cfm reclaimer, 60 to 180-mesh
- With 600 cfm reclaimer, 46 to 180-mesh

Media sizes listed are for guidelines only. The guidelines are based on standard nozzle size and average conditions, such as blast pressure, media/air mixture, visibility inside the cabinet, humidity, and reclaimer cleaning rate.

Several factors affecting the reclaimer cleaning rate include: reclaimer size (cfm), contamination of parts being blasted, media friability, damper setting (static pressure), and dust collector filter loading (differential pressure across the filter cartridge(s)).

As a rule, larger nozzles deliver more media, requiring higher performance from the reclaimer. When using larger nozzles, the maximum mesh size of media will be smaller than those normally recommended. Using media finer than those recommended may decrease visibility, and increase carryover to the dust collector. Media coarser than those recommended may be too dense for the reclaimer to recover from the cabinet hopper.

1.8.2 Steel: Steel grit or shot should not be used with the BNP-55 Cabinet. The cabinet is too small to prevent peening of the cabinet weldment, and 300 and 600 cfm reclaimers are too small to efficiently convey metallic media.

1.8.3 Sand and Slag: Sand should NEVER be used because of the respiratory hazards associated with media containing free silica. Slags are not recommended because they rapidly break down. Slags are not recommended because they rapidly breakdown and are not recyclable, making them unsuitable for cabinet applications.

1.8.4 Silicon Carbide, Aluminum Oxide, and Garnet: These are the most aggressive of the commonly used media. Aggressive media may be used, but the service life of any equipment components exposed to the media will be reduced. To avoid unscheduled down time, periodically inspect the reclaimer wear plate, blast hose, flex hoses, and nozzle for wear.

When using aggressive media only occasionally, install an optional aluminum oxide kit. The kit includes rubber curtains for the cabinet interior and a boron carbide lined nozzle. When using aggressive media on a regular bases, with a 600 cfm reclaimer, install an aluminum oxide kit and a fully-rubber lined. **Note rubber-lined reclaimers are available as factory installed items and field installed on reclaimers with removable tops and designed to accept liners.** Nozzles lined with boron carbide extend nozzle wear life. Refer to Section 9.3

1.8.5 Glass Bead: Recommended bead sizes are No. 6 through No. 12. Most beads are treated to ensure free-flow operation even under moderately high-humidity. Glass beads subjected to excessive moisture may be reused after thorough drying and breaking up any clumps.

1.8.6 Lightweight and Fine-mesh Media: When using lightweight (such as agricultural) media or fine mesh (180-mesh and finer) media, the reclaimer inlet baffle may need to be removed to retain media and avoid carryover. On reclaimer models with bolt-on removable tops, baffle removal and replacement is easily accomplished. Reclaimers with welded-on tops require grinding to remove the baffle and once it is removed it cannot be replaced.

1.8.7 Plastic Media: Plastic and similar lightweight and/or non-aggressive media are generally not recommended for suction-style cabinets because the lower blast velocity of suction blasting combined with the softer and lighter weight media, do not provide the media impact for productive blasting. Best performance from plastic media is achieved with pressure blasting, requiring a pressure vessel with a 60-degree conical bottom. Refer to Clemco's AEROLYTE cabinet line.

1.8.8 Bicarbonate of Soda: Bicarbonate of soda is not recommended for use in standard cabinets. Bicarb is a one-use media usually used and will quickly saturate the filter cartridge(s). Best performance from bicarb media is achieved with pressure blasting, requiring a pressure vessel. Refer to Clemco's AEROLYTE cabinet line for cabinets that are specifically designed for use with bicarbonate of soda.

1.9 Compressed Air Requirements

1.9.1 The size of the compressor required to operate the cabinet depends on the size of the air jet and blasting pressure. Unless otherwise specified, cabinets are supplied with a No. 5 (5/32" orifice) jet. Refer to the table in Figure 3 to determine cfm requirements. Consult with a compressor supplier for suggested compressor size based on the air consumption. **NOTE: A separate air line is required for the reverse-pulse dust collector. If preferred, remove the plug from the auxiliary air-port (shown in Figure 4) and connect a 1/4" ID or larger air line to the dust collector pulse reservoir/manifold.**

BNP Gun	Jet	Nozzle	CFM	PSI
No. 4	1/8"	5/16"	21	80
No. 5	5/32"	5/16"	32	80
No. 6	3/16"	3/8"	47	80
*No. 7	7/32"	7/16"	62	80
*No. 8	1/4"	1/2"	86	80

* Using this combination could affect usable media size, refer to Section 1.8.

Figure 3

1.9.2 The air filter at the air inlet connection reduces condensed water from the compressed air. Its use is especially important in areas of high humidity, or when using fine-mesh media. Moisture causes media to clump and inhibits free flow through the feed assembly. If the filter does not remove enough moisture to keep media dry and flowing, it may be necessary to install an air dryer or aftercooler in the air supply line.

1.10 Electrical Requirements

All wiring external to the cabinet is provided by the user to comply with local electrical codes.

1.10.1 Electrical requirements depend on the size and phase of the dust collector exhaustor motor. **NOTE:** Full load amps (FLA) shown below are for the motor only; the lights draw less than one amp. Standard cabinets are supplied as follows:

300 cfm: 1/2 HP, 115/208/230V, 1-PH, 60 HZ
115, FLA 115/7, 208/3.4, 230/3.5.
600 cfm: 1 HP, 115/230V, 1-PH, 60 HZ
115, FLA 115/12, 208/6.6, 230/6.2.

Refer to Section 2.5 to connect electrical service

2.0 INSTALLATION

2.1 General Installation Notes

2.1.1 Refer to Figure 1 (and Figure 2 for optional RPC-2 dust collector) for the general arrangement. Place all components in a convenient location where compressed air and electrical service are available. The cabinet location must comply with OSHA and local safety codes. Allow for full access to all doors and service areas, and for efficient handling of large parts. Provide enough clearance at the dust collector for maintenance and to remove the dust container. Determine the best location for all components and position them before making compressed air connections, electrical connections, and attaching flex hose.

2.1.2 Refer to the dust collector owner's manual to set up the dust collector and prepare it for operation.

2.2 Connect Conveying Hose

2.2.1 Connect the smaller diameter flex hose between the cabinet hopper pipe adaptor and reclaimer inlet adaptor, and connect the larger diameter hose between the reclaimer outlet and dust collector inlet. It is easier to slip the hose over the adaptors and create a tighter seal if the first two or three inches of wire are removed from the inside of the hose. Use care not to damage the hose. Clamp flex hose securely in position with worm clamps provided. NOTE: The hose wire helps dissipate static electricity in the conveying hose, and also helps ground each segment. In order for the hose wire to dissipate static electricity, the wire must touch the metal of each segment.

2.3 Connect Compressed Air Supply Line(s)

⚠ WARNING

Failure to observe the following before connecting the equipment to the compressed air source could cause serious injury or death from the sudden release of compressed air.

- Lockout and tagout the compressed air supply.
- Bleed the compressed air supply line.

⚠ WARNING

To avoid the risk of injury from compressed air, install an isolation valve and bleed-off valve where the air supply is tapped into the compressed air system. This enables depressurization of the compressed-air line before performing maintenance.

2.3.1 Refer to Paragraph 2.3.2 to determine the recommended air supply hose size, then refer to Figure 5 and apply thread sealant to the male threads of an air fitting that is compatible with the air supply hose fitting, and install it onto the 1/2-NPT air filter located under the cabinet hopper. **Note that the style of connection shown in Figure 4 is for reference only.**

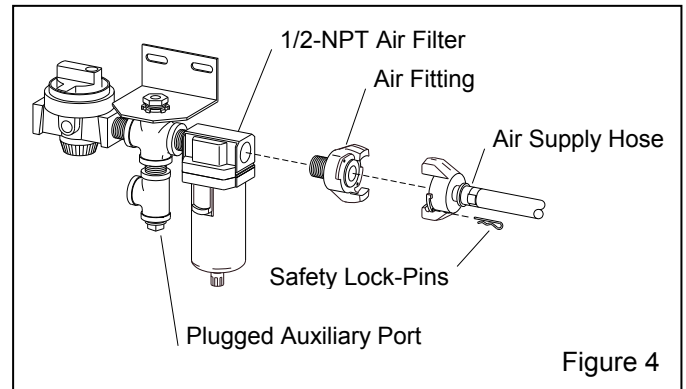

Figure 4

2.3.2 Refer to the table in Figure 5 to determine the minimum ID air supply line to the cabinet air inlet. A smaller diameter hose may reduce blasting efficiency.

MINIMUM COMPRESSED AIR LINE ID			
Air Line Length	Air Jet Size		
	No. 4	No. 5	No. 6
25 feet	3/4"	3/4"	1"
50 feet	3/4"	3/4"	1"
75 feet	3/4"	1"	1"
100 feet	3/4"	1"	1"

Figure 5

2.3.3 Connect the air line from the air source to the air filter inlet.

⚠ WARNING

If twist-on type air hose couplings are used, they must be secured by safety pins or wires to prevent accidental disconnection while under pressure. Hose disconnection while under pressure could cause serious injury.

2.3.4 Refer to the dust collector owner's manual and connect a compressed-air line to the pulse manifold.

2.4 Ground Cabinet

2.4.1 To prevent static electricity build up, attach an external grounded wire from an earth ground to the grounding lug on the left rear of the cabinet.

2.5 Connect Electrical Service

⚠ WARNING

Shorting electrical components could result in serious electrical shocks, or equipment damage. Electrical power must be locked out and tagged out before performing any electrical work. All electrical work or any work done inside a control panel or junction box must be performed by a qualified electrician, and comply with applicable codes.

All wiring external to the cabinet is provided by the user to comply with local electrical codes.

2.5.1 Single-Phase Wiring

2.5.1.1 Standard 300 cfm 600 cfm cabinets and dust collectors are 115-volt single phase. Incoming power to the cabinet is supplied by a U-ground plug; plug it into a 115-volt outlet.

⚠ WARNING

Do not use electrical adaptors that eliminate the ground prong on 115 volt plugs. Doing so could cause electric shock and equipment damage.

2.5.1.2 Refer to the wiring schematic in Figure 6 and wire the dust collector motor per instruction on the motor data-plate, to the junction box mounted on the cabinet. When wired as noted in Figure 6, the dust collector

exhauster motor will start when the cabinet light switch is turned ON, and stop when the switch is turned OFF.

2.5.2 Three-Phase Wiring

2.5.2.1 Refer to the wiring schematic stowed inside the control panel mounted on the cabinet and wire from the users disconnect to the panel and from the panel to the dust collector motor, per instruction on the motor data-plate.

2.5.2.2 Check the amperage on initial start up; if the motor draws excessive amperage, gradually close the dust collector damper, located on the inlet on CDC dust collectors, and on the exhauster outlet on RPC and RPH dust collectors, until the amperage is within the specifications shown on the motor plate.

2.5.3 Check Motor Rotation

2.5.3.1 After wiring is completed, observe the warning that follows and check the motor rotation. To check rotation, turn the On-Off switch ON and quickly turn it OFF, causing the motor to rotate slowly. Look through the slots in the motor fan housing where rotation of the fan can easily be observed. Proper rotation is indicated by the arrow on the exhauster housing; the fan should rotate toward the exhauster outlet. If it rotates in reverse, change the wires as noted on the motor plate to reverse rotation.

⚠ WARNING

Do not look into the exhauster outlet while the paddle wheel is turning. Injury to the eye or face could occur from objects being ejected from the exhauster.

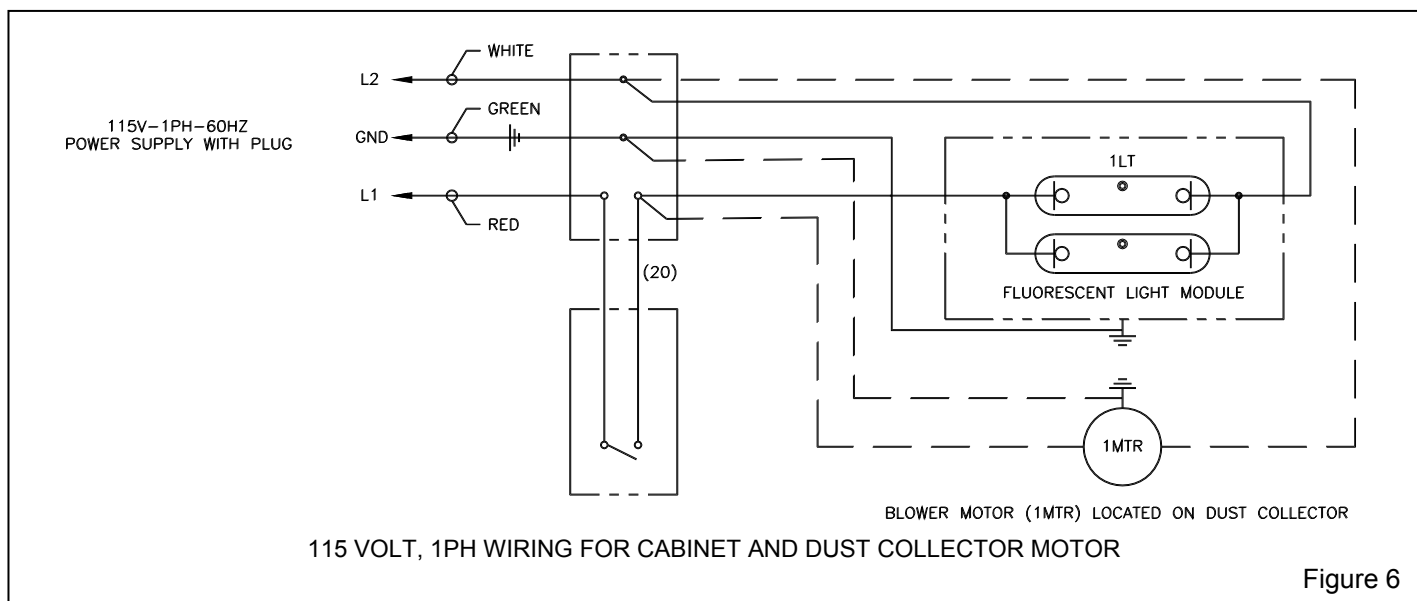

Figure 6

2.6 Cabinet Air-Inlet Damper, refer to Figure 7

2.6.1 The air-inlet damper is located on the top of the cabinet and must be set to match the cabinet dimensions and reclaimer size. The air-damper was preset prior to shipment; confirm the initial setting as noted below.

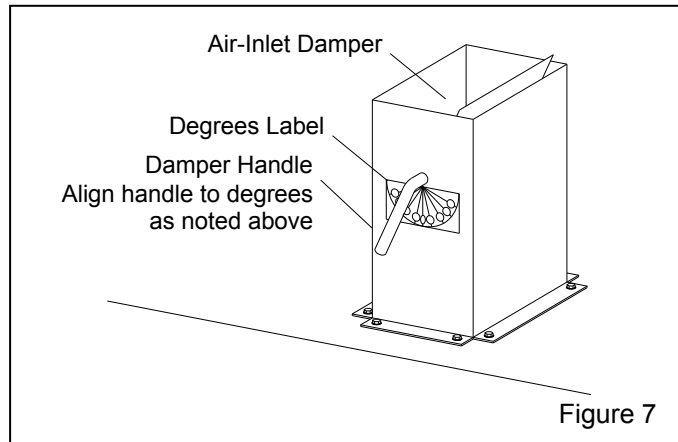

Figure 7

2.6.2 The label on the damper show the settings in degrees. The initial setting should align the handle as follows.

- 55 with 300 reclaimer align handle to 30 degrees
- 55 with 600 reclaimer align handle to 30 degrees

2.6.3 Loosen the lock nuts and align the damper handle as noted. When correctly positioned, tighten the lock nuts to maintain the setting. Refer to Section 5.6 for adjustment procedure.

2.7 Final Assembly

2.7.1 Position the foot pedal on the floor at the front of the cabinet.

2.7.2 A package of five view-window cover-lenses is supplied with the cabinet. Install a cover lens per Section 7.3. When the cover lens becomes pitted or frosted, replace it.

3.0 FIELD INSTALLED ACCESSORIES

3.1 Aluminum Oxide Kit

3.1.1 An optional aluminum oxide kit is available factory installed or may be field installed later.

Filed-installed (or replacement factory installed) kits consist of black rubber curtains with grommets, curtain hardware, boron carbide nozzle and light-lined flex hose. If the existing flex hose is in good condition, reserve the new hose for future replacement.

3.2 Curtain Installation

3.2.1 Match curtains to corresponding wall and doors.

3.2.2 Front and rear walls: Position the curtain on the wall to be protected. Using the curtains as templates, mark each mounting point through the grommet holes along the upper edge of the curtain. NOTE: When laying out the attachment points, the upper edge of the rear curtain should be below the bottom edge of the air duct partition. Remove the curtains, and drill a .187" (3/16") diameter hole at each point marked. Install the curtains using the fasteners provided (machine screw, 11/16" OD flat washer, lock washer and nut) at each grommet. The flat washer is used between the screw head and the rubber curtain grommet on all curtains.

3.2.3 Doors: Using protectors against the curtains and outer doors, clamp the door curtains in place. NOTE: When laying out the attachment points, the upper edges of the door curtains should be even with the outer edges of the door's sound proofing panel. Insert a #10 self-drilling screw with an 11/16" OD flat washer through the grommet holes. Use a screw gun with a 5/16" socket to drill and thread the screws through the door's inner wall at each grommet.

3.3 Manometer

The optional manometer kit is listed in Section 9.1.

3.3.1 Consistent static pressure is necessary for precise media separation, as the reclaimer's efficiency is achieved by a centrifugal balance of air flow, particle weight, and size. The manometer measures static pressure. Reclaimer static pressure is set by adjusting the dust collector damper. Refer to Section 5.4 to adjust static pressure. Refer to Section 5.8 for instructions on using the manometer.

3.4 Armrest

3.4.1 Assemble the armrest and mounting brackets as shown in Figure 8.

3.4.2 Position the assembly so the armrest is about even with the bottom of the arm-port opening. Mark one hole location on the front of the cabinet at each mounting bracket.

3.4.3 Drill a 3/8" hole at both locations and mount the armrest using 5/16 cap screw, washers and nuts. Install the bolts from inside the cabinet to protect the threads from abrasion, should the armrest need to be removed at a later date.

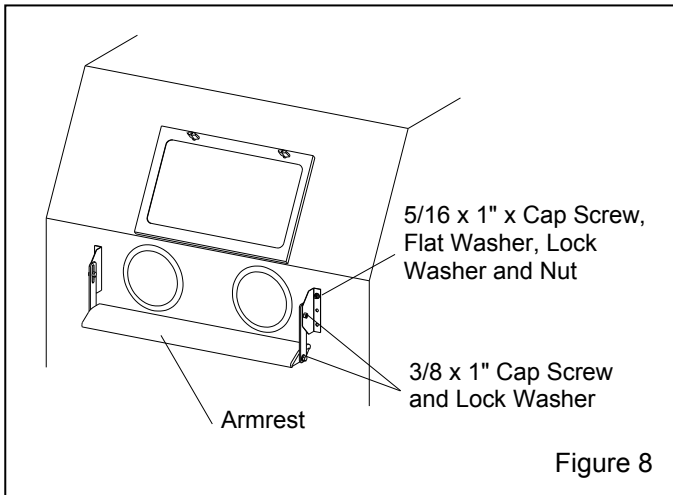

Figure 8

3.4.4 Match drill the remaining four bracket holes and install the remaining fasteners.

3.4.5 Loosen the fasteners on the slotted bracket and raise or lower the armrest to a comfortable position.

3.5 Track and Low Profile Table, Maximum Weight Capacity 500 Lbs.

3.5.1 Components of track and table assembly are shown in Figure 9. The assembly consists of:

1. Track assembly: mounts inside the cabinet.
2. Table assembly: rollers on sliding table fit inside the track rails.
3. All necessary mounting fasteners.

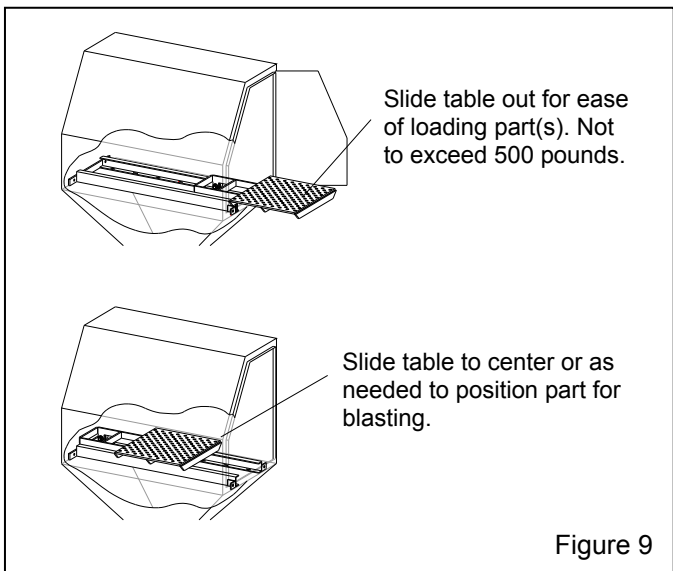

Figure 9

NOTE: The track may be installed to permit the table to slide out through either the right side or left side door. The right side is shown in the illustrations.

3.5.2 Combine the table assembly and track by sliding the table assembly rollers into the track channels, as shown in Figure 10.

NOTE: If the weight of the table and track make it too heavy to install as an assembly, the track may be placed in the cabinet to predrill mounting holes, but the table must be placed within the rails before fasteners are installed.

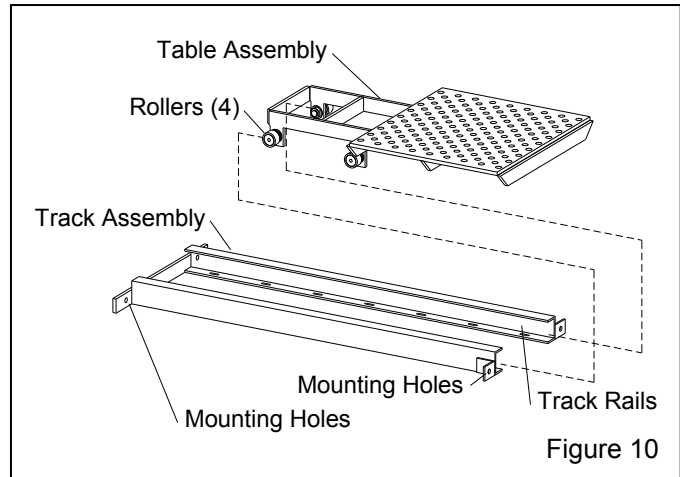

Figure 10

3.5.3 Center the track and table assembly inside the cabinet on top of the grate. Make sure the two angled mounting brackets are facing toward the door from which the table will slide, refer to Figure 11.

3.5.4 Match drill two 1/2" diameter holes on each side of the cabinet, using the holes in the mounting brackets as a template. **NOTE:** To prevent the track from shifting, temporarily place a 3/8-NC x 1-1/2" bolt through each hole after it is drilled.

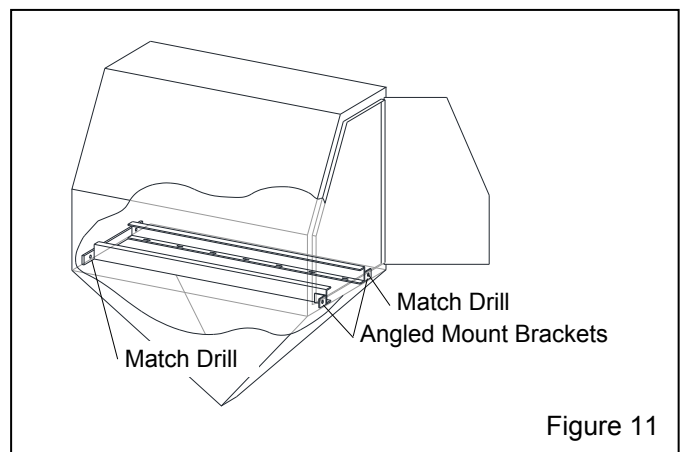

Figure 11

3.5.5 After the holes are drilled and the table assembly is placed in the track rails, secure all fasteners.

4.0 OPERATION

4.1 Media Loading and Unloading

4.1.1 Media Loading: With the exhauster OFF, add clean dry media by pouring it into the reclaimer hopper through the reclaimer door. Do not fill above the cone on the reclaimer. **Do not pour media directly into the cabinet hopper, as overfilling may occur.** Overfilling will result in media carryover to the dust collector and possible blockage in the conveying hose. Refill only after all media has been recovered from the cabinet.

The minimum amount of media to charge the system is:

300 CFM Reclaimer.....10 Lbs. Media

600 CFM Reclaimer.....20 Lbs. Media

4.1.2 Media Unloading: To empty the cabinet and reclaimer of media, blow-off the cabinet interior and run the exhauster until all media is recovered from the cabinet. Turn OFF the exhauster, and place an empty container under the reclaimer's metering valve. Unscrew the plastic plug from the metering valve, permitting media to flow into the container. If media doesn't flow, it has caked. Open the fill door and stir media until it starts to flow. Replace the plug when the reclaimer is empty.

4.2 Loading and Unloading Parts

WARNING

Use solid fixturing to hold heavy parts in place. Do not remove lift equipment until the part is adequately supported to prevent movement. Moving heavy, unsupported parts may cause them to shift or topple, and cause severe injury. This is especially important with the use of turntables and work table with track.

4.2.1 Load and unload parts through either door.

4.2.2 Parts must be free of oil, water, grease, or other contaminants that will clump media or clog filters

4.2.3 When blasting small parts or objects having small pieces that could become dislodged and fall off, place an appropriately-sized screen over the grate (or under the grate when frequently blasting small parts) to prevent parts from falling into the hopper.

4.2.4 Close door; the door interlock system will prevent blasting if either door is open.

4.3 Blasting Operation

WARNING

- **Always close cabinet, reclaimer and dust collector doors before blasting. Keep all doors closed during blasting.**
 - **Always wear blast gloves.**
 - **Avoid pointing the blast nozzle toward the view window.**
 - **Use the blow-off nozzle to blow media off parts before opening doors.**
 - **After blasting, keep doors closed and exhauster running until the cabinet is clear of all airborne dust.**
 - **Stop blasting immediately if dust leaks are detected.**
-

4.3.1 Slowly open the air valve on the air supply hose to the cabinet. Check for air leaks on the initial start up and periodically thereafter.

4.3.2 Turn ON the lights and exhauster. The ON/OFF switch located on the light shield performs both functions.

4.3.3 Load parts.

4.3.4 Close door; the door interlock system will prevent blasting if either door is open.

4.3.5 Adjust the pilot pressure regulator to the required blast pressure, per Section 5.1. The regulator is located on the top, left side of the cabinet.

4.3.6 Insert hands into rubber gloves.

4.3.7 To blast, hold the gun firmly, point the gun toward the object to be blasted, and apply pressure to the foot pedal; blasting will begin immediately.

WARNING

Shut down the cabinet immediately if dust discharges from the dust collector or cabinet. Make sure dust collector filter(s) are correctly seated and not worn or damaged. Prolonged breathing of any dust could result in serious lung disease or death. Short term ingestion of toxic dust such as lead, poses an immediate danger to health. Toxicity and health risk vary with type of media and dust generated by blasting. Identify all material being removed by blasting, and obtain a safety data sheet (SDS) for the blast media.

NOTE: When blasting parts off the grate, use a solid conductive back rest to support the part. Without this assist, especially with longer blasting operations, the operator will tire easily from resisting blast pressure, and static electricity could build up in the ungrounded part and cause static shocks. Whenever possible avoid holding small parts that require blasting into the glove.

4.3.8 If an object should fall through the grate, stop blasting immediately and retrieve it.

4.4 Stop Blasting

4.4.1 To stop blasting, remove pressure from the foot pedal.

4.4.2 Use the blow-off nozzle to blow media off cleaned parts.

4.4.3 Keep doors closed and exhauster running until the cabinet is clear of all airborne dust.

4.4.4 Unload parts. Shut off the air supply valve, drain the air filter, and switch OFF the lights and exhauster.

4.5 Blasting Technique

4.5.1 Blasting technique is similar to spray painting technique. Smooth continuous strokes are most effective. The distance from the part affects size of blast pattern. Under normal conditions, hold the nozzle approximately 3" to 6" from the surface of the part.

5.0 ADJUSTMENTS

5.1 Blasting Pressure

5.1.1 The pilot regulator located on the top, left side of the cabinet, enables the user to adjust blasting pressure to suit the application. The suitable pressure for most purposes is about 80 psi. Lower pressures may be required on delicate substrates, and will reduce media breakdown. Higher pressure may be required for difficult blasting jobs on durable substrates, but will increase media break down. If pressure is too high, suction in media hose will decrease, and if high enough cause blow-back in the hose. Optimal production can only be achieved when pressure is carefully monitored.

5.1.2 To adjust, pressure, unlock the knob by pulling it out as shown in Figure 12, and turn it clockwise to increase pressure or counter-clockwise to decrease pressure. Pressure will usually drop from closed-line

pressure when blasting starts. Once operating pressure is set, lock the knob to maintain the setting.

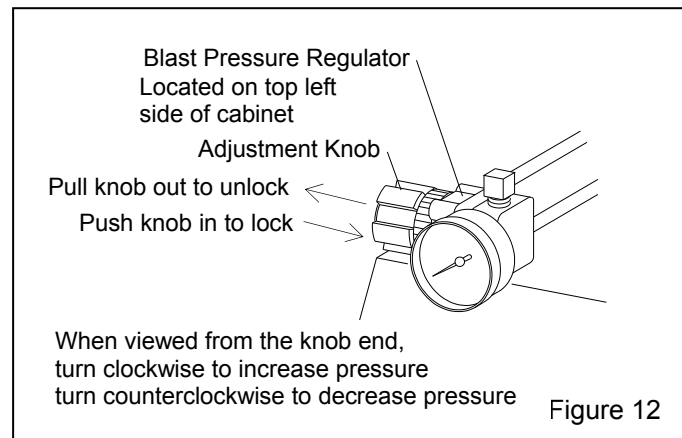

5.2 Air Jet Adjustment, Figure 13

5.2.1 Thread the air jet 4-1/2 to 5 full turns into the gun body. Doing so will leave 3-1/2 to 4 threads exposed past the lock nut. Tighten the lock nut to maintain the setting. Refer to Section 9.3 for optional adjusting tool, which correctly positions the jet.

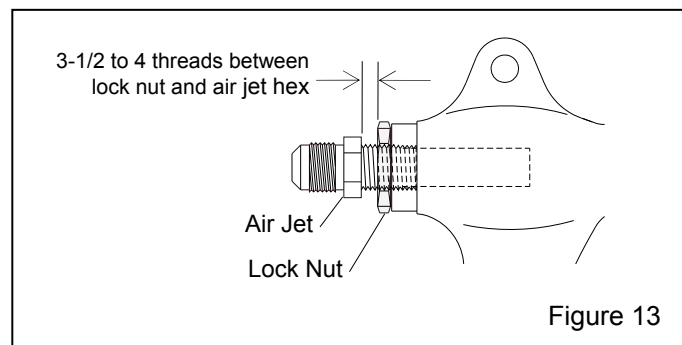

5.3 Media/Air Mixture, Figure 14

5.3.1 Check the media stream for correct media/air mixture; media flow should be smooth and appear as a light mist coming from the nozzle.

5.3.2 If media does not flow smoothly, loosen the locking nut and adjust the metering screw until the upper holes in the metering stem are closed-off, and the lower holes are fully open, as shown in Figure 14. This adjustment is a starting point.

5.3.3 If pulsation occurs in the media hose, either media is damp and caked, or not enough air is entering the media stream. While blasting, loosen the locking nut and slowly turn the adjusting screw out (counterclockwise when viewed from the top) until the media flows smoothly. Tighten the locking nut finger-tight to maintain the setting.

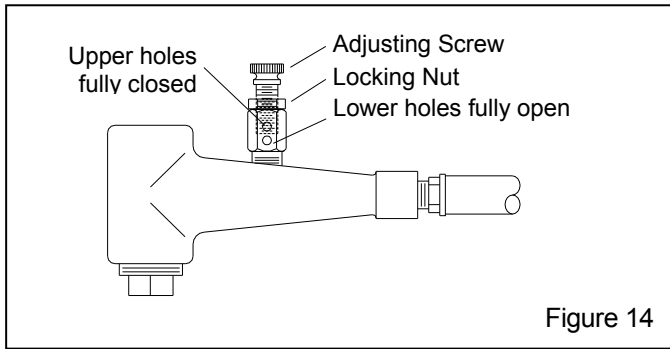

5.3.4 If media flow is too light, decrease air in the mixture by turning the metering screw in (clockwise when viewed from the top) covering more of the holes so less air enters the media hose. Tighten the locking nut finger-tight to maintain the setting.

5.4 Reclaimer Static Pressure

5.4.1 Correct static pressure varies with size of reclaimer and the size, weight and type of media.

5.4.2 Adjust static pressure by opening (handle inline with air flow) or closing (handle perpendicular to air flow) the dust collector ventilation damper. Refer to the dust collector owner's manual, the damper is located on the inlet on CDC dust collectors, and on the exhaust outlet on RPC and RPH dust collectors. If the damper is not opened far enough, the reclaimer will not remove fines, resulting in dusty media, poor visibility, and possible media blockage in the conveying hose. If the damper is opened too far, it may cause carryover (usable media carried into the dust collector) and result in excessive media consumption. Open only as far as necessary to obtain a balance of dust removal without media carryover.

5.4.3 A manometer is useful when adjusting or monitoring static pressure. The manometer kit is listed under Optional Accessories in Section 9.1. Refer to Section 5.8 for manometer operation. The following are static pressure starting points for given media. Static pressure may need to be lower with finer media, higher with coarser media. Run the media through several blast cycles allowing the reclaimer to function with these settings. Inspect the media in the reclaimer and fines in the dust collector as noted in Paragraph 5.4.2. Continue adjusting static pressure until optimum media cleaning without carryover is attained.

Glass Bead No. 4 to 7	3" to 3-1/2"
Glass Bead No. 8 to 13	2-1/2 - 3"
Alox. 60 & coarser	4 - 5"
Alox. 80 & finer	2-1/2 - 3"

5.4.4 If the damper has been adjusted and carryover or excessive dust in the media continues to be a problem, the optional adjustable vortex cylinder may help retain media. The vortex cylinder is usually required only when using 180-mesh and finer media, or lightweight media. Refer to Section 5.5.

5.5 Optional Externally-Adjustable Vortex Cylinder
Not available for 300 cfm reclaimer

NOTE: The externally adjustable vortex is an option when the cabinet is provided with a CDC-1 Dust collector. The vortex is standard with 600 cfm reclaimers when the cabinet is provided from the factory with an RPC dust collector.

The vortex cylinder fine-tunes media separation. Before adjusting the cylinder, adjust the damper on the dust collector to increase or decrease static pressure per Section 5.4. Once the damper is adjusted, adjust the cylinder.

5.5.1 The vortex cylinder is located atop the reclaimer where the flex hose connects. Adjustments are made by loosening the handle's tensioning knob and moving the handle to achieve the correct setting. When the correct setting is established, tighten the locking knob to prevent movement. Start with the lever slightly to the right (about one o'clock as shown in Figure 15) of the vertical position.

5.5.2 To Remove More Fines: (Too much dust in media) Raise the cylinder by moving the lever left toward "COARSE", in 1/4" increments at the indicator plate. Allow the media to go through several blast cycles before determining if further adjustment if needed.

5.5.3 To Remove Less Fines: (Excessive usable media is carried to the dust collector) Lower the vortex cylinder by moving the lever right toward "FINE", in 1/4" increments at the indicator plate. **NOTE:** If the cylinder is lowered too far, the reclaimer will again begin to allow usable media to be carried over, and cause abnormally high static pressure.

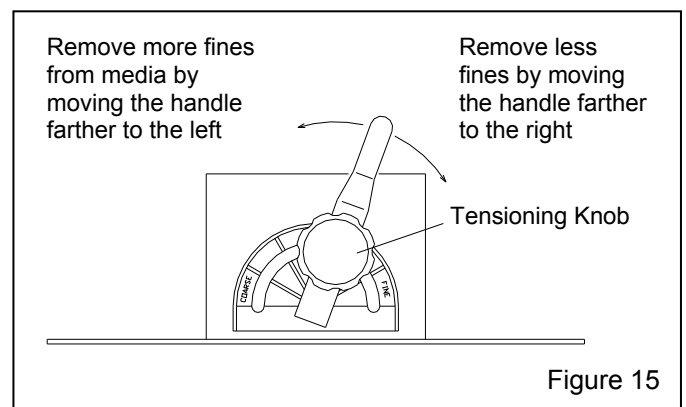

5.5.4 When using media finer than 180-mesh, the inlet baffle of the reclaimer may need to be removed. Refer to Section 1.8.6.

5.6 Cabinet Air-Inlet Damper

5.6.1 Once the inlet is initially set per Section 2.6, it seldom requires readjustment. The initial setting produces approximately .5" to .75" of static pressure in the cabinet enclosure. **Do not confuse cabinet static pressure with reclaimer static pressure, which is controlled by the dust collector damper as noted in Section 5.4. Reclaimer pressure must be set before cabinet pressure.**

5.6.2 Using a manometer (as noted in Section 5.8 and listed in Section 9.1) is the most accurate method of monitoring and adjusting cabinet pressure. Following the instructions packed with the manometer, start the exhauster and insert the needle into a glove, and adjust pressure using the cabinet's air-inlet damper. Open the damper farther to decrease static pressure or close it farther to increase pressure.

5.6.3 If a manometer is not available, use the gloves as an indicator. With the exhauster ON, the gloves should be inflated, but not elevated off the grate.

5.7 Door Interlocks, Figure 16

⚠ WARNING

Never attempt to override the interlock system. Doing so could result in injury from unexpected blasting.

5.7.1 The door interlocks disable the blasting control circuit when the doors are open. To enable blasting, the door interlock switches must be engaged when the doors are closed. The interlocks are set at the factory and do not normally require field adjustment unless parts are replaced. When adjustment is required, proceed as follows.

5.7.2 Close cabinet doors.

5.7.3 Loosen the actuator bracket screws and adjusting screw nut. Move the actuator adjusting bracket up or down, and the adjusting screw sideways, to center the adjusting screw on the over-travel stop. Tighten the bracket screws.

5.7.4 Turn the adjusting screw in or out as required to engage the switch without applying excessive pressure on it. Tighten the adjusting screw nuts.

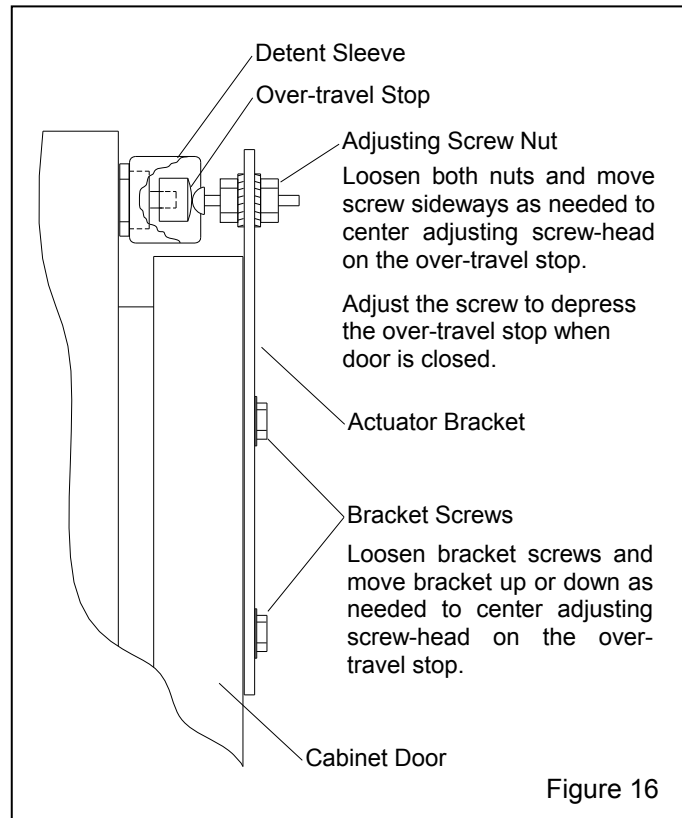

5.7.5 Test the operation with the doors open and then again closed. Point the nozzle away from the door during the tests, and open the door only enough to disengage the interlock switch. The interlocks should stop the blasting when the doors are opened, and permit blasting when the doors are closed. NOTE: Negative pressure inside the cabinet may cause the doors to flex inward. Tests should be performed with the exhauster running.

5.8 Optional Manometer

These instructions show several methods of taking static-pressure readings (negative pressure) on cabinet reclaimers, using a flexible tube manometer. Use the method best suited for the application. The instruction explains the processes for taking periodic readings and shows how to permanently install the manometer for taking frequent readings. Permanent fittings should be installed when rigid ducting is used, or when the manometer installation is permanent. Use silicone sealer or other sealant to seal around the fitting to prevent leaks. The fitting should be capable of being capped when the manometer tube is removed. Capping the fitting will prevent leaks that alter the reclaimer's separation efficiency. The readings are reference points so it doesn't matter where the readings are taken as long as they are always taken at the same location. Taking readings at different locations could produce different results. Static-pressure readings at the door are generally .5" to 1" lower than those taken above the reclaimer.

5.8.1 Refer to directions packed with the manometer for preparation and operating instructions for the manometer.

5.8.2 Connect one end of the 3/16" ID tubing to one of the tubing connectors (elbow) at the top of the manometer by pushing it over the barbed adaptor.

5.8.3 Leave the needle protector on the needle and insert the needle into the other end of the tubing. The ends of the tubing must fit tight on the manometer and needle; leaks will give inaccurate readings.

5.8.4 Open both manometer valves (elbows) per the instructions provided with the manometer.

5.8.5 Magnets on the manometer hold it in position on the reclaimer body. The manometer must be vertically-plumb so the fluid is level on both sides.

5.8.6 Adjust the slide rule to align the zero with the fluid level. Refer to Figure 18

5.8.7 Needle placement: Ref. Figure 17.

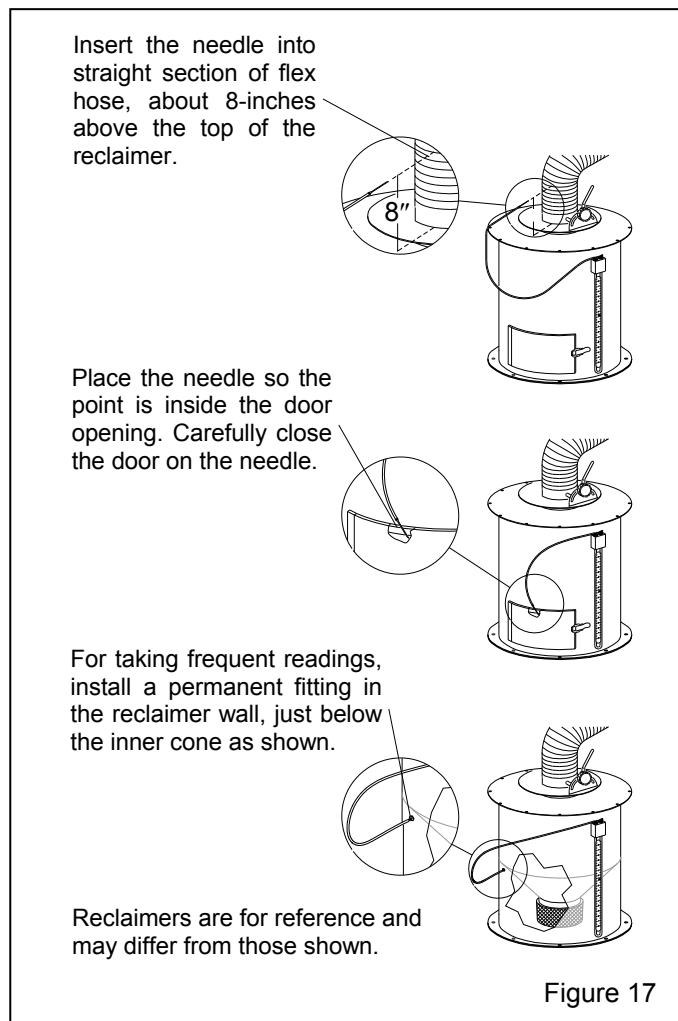

5.8.7.1 Taking readings in the flex hose: Remove the needle protector, and insert the needle into the flex hose approximately 8" from the top of the reclaimer.

5.8.7.2 Taking readings at the reclaimer door: Open the reclaimer fill door, remove the needle protector and place the needle so the point is inside the door opening. Carefully close the door on the needle. The side of the needle will embed into the rubber, creating an airtight seal.

5.8.8 Turn the exhauster ON. The negative (static) pressure will move fluid in the tube. **NOTE: Readings must be taken with the cabinet doors open, and with the exhauster running.**

5.8.9 To find the static pressure, add the number of inches the fluid travels up one column to the inches the fluid travels down the other column. Refer to the example in Figure 18.

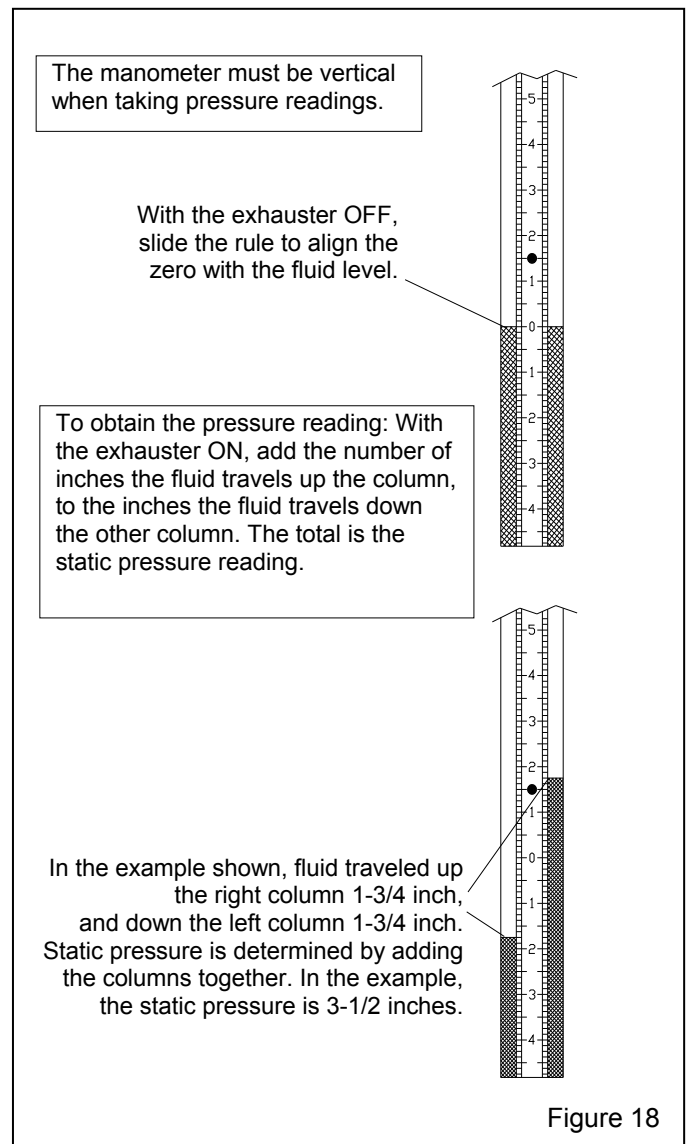

5.8.10 After the readings are taken, replace the needle protector. Close the manometer valves and store the manometer in the original container in a clean area.

NOTE: If the manometer installation is permanent, the manometer may remain on the reclaimer body after the valves are closed.

6.0 PREVENTIVE MAINTENANCE

NOTE: To avoid unscheduled downtime, establish an inspection schedule. Inspect all parts subjected to media contact, including; the gun, nozzle, media hose, flex hose, wear plate, plus all items covered in this section.

6.1 Daily

6.1.1 Check media level in reclaimer and refill as necessary.

6.1.2 Check reclaimer debris screen for debris. The screen is accessible through the reclaimer door. With the exhauster OFF, remove the screen and empty it daily or when loading media. Empty the screen more often if part blasted causes excessive debris. Do not operate the machine without the screen in place.

6.1.3 The cabinet is equipped with a manual-drain air filter. Drain the filter at least once a day, and more often if water is present. Moist air inhibits the flow of media. Drain the air line and receiver tank regularly. If the filter does not remove enough moisture to keep media dry and flowing, it may be necessary to install an air dryer or aftercooler in the compressed-air supply line.

6.1.4 Refer to the dust collector owner's manual and empty dust containers. Adjust intervals based on filling rate.

6.1.5 Refer to the dust collector owner's manual and drain the pulse manifold at the end of each shift.

6.1.6 Refer to the CDC-1 dust collector manual for pulsing instructions and pulse the cartridge at least every half hour of blasting and before turning OFF the exhauster. Dusty blasting conditions will require more frequent pulsing. RPC and RPH dust collectors are automatically pulsed at timed intervals.

6.2 Weekly

6.2.1 Inspect view window cover lens, Replace as needed per Section 7.3.

6.2.2 Inspect gloves for wear. The first sign of deterioration may be excessive static shocks. Replace as needed per Section 7.1.

6.2.3 Inspect internal parts of the BNP gun for wear. Replace parts as needed per Section 7.2.

6.2.4 Inspect flex hoses for wear.

6.2.5 During operation, inspect cabinet door seals for media leaks.

6.2.6 Inspect the media hose for thin spots, by pinching it every 6 to 12 inches. Replace the hose when it becomes soft.

6.3 Monthly

6.3.1 Inspect reclaimer wear plate per Section 7.8 or rubber liners per Section 7.9 for wear. Replace as necessary.

6.3.2 Inspect reclaimer door gasket for wear or other damage.

6.4 Dust Collector

Reverse-pulse dust collectors are covered in a separate manual. Refer to Section 1.1.1.

7.0 SERVICE MAINTENANCE

WARNING

Failure to wear approved respirators and eye protection when servicing dust-laden areas of the cabinet and dust collector, and when emptying the dust bag or collector could result in serious eye irritation and lung disease or death. Toxicity and health risk vary with type of media and dust generated by blasting. Identify all material being removed by blasting, and obtain a safety data sheet (SDS) for the blast media.

7.1 Gloves

7.1.1 Special static-dissipating gloves are provided for operator comfort. It will be necessary to change gloves

periodically as they wear. The first sign of deterioration may be excessive static shocks.

7.1.2 Band-clamp type: Band-clamp type gloves are held in place by metal band-clamps on the inside of the cabinet. To replace, loosen the clamps with a screwdriver, replace the gloves, and tighten the clamps.

7.1.3 Quick-Change type, clampless installation: Quick-change gloves are held in place using spring rings sewn into to the attachment end of the glove. To install, insert the glove into the arm port, so one spring is on the inside of the port and the other is on the outside, sandwiching the arm port between both spring rings.

7.2 BNP Gun Assembly, Figure 19

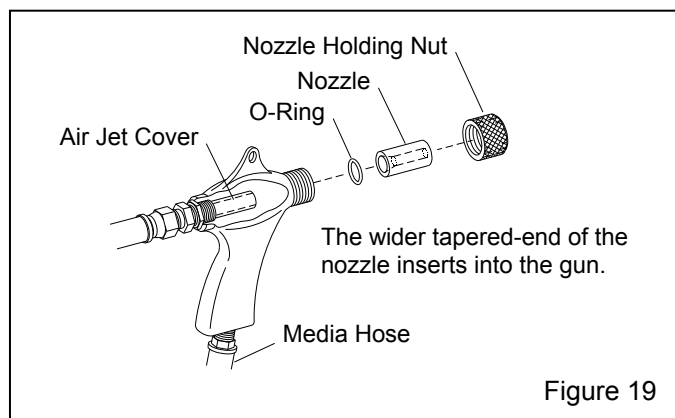

Figure 19

7.2.1 Replace the nozzle when its diameter has increased by 1/16", or when suction diminishes noticeably. To change the nozzle, unscrew the holding nut from the gun end, and pull the nozzle from the gun. Inspect the nozzle o-ring and replace if worn or damaged. Insert a new nozzle, placing the tapered end toward the jet. Screw the holding nut onto the gun.

7.3 View Window Cover Lens

7.3.1 Rapid frosting of the view window can be avoided by directing ricocheting media away from the window, and by installing a cover lens on the inside surface of the window. Using cover lenses prolongs the life of the view window.

7.3.2 The best way to install a cover lens is to remove the window from the cabinet. If, for some reason, it is not practical to remove the window, the lens may be applied with the window glass in place.

7.3.3 To install a cover lens, carefully remove the adhesive backing making sure the adhesive remains on the lens, and apply the lens to the clean, dry, inner surface of the view window. When the cover lens becomes pitted or frosted, replace it.

7.4 View Window Replacement

⚠ WARNING

Do not use plate glass for replacement view windows. Plate glass shatters on impact and could cause severe injury. Use only genuine ZERO® laminated replacement glass.

7.4.1 Lift the light shield up and remove the two window frame nuts located on the upper edge of the window frame, and swing the window frame open. If the frame is to remain open, for cleaning or other reasons, remove it per Section 7.6.

7.4.2 Remove the old window.

7.4.3 Inspect the window frame gaskets, both on the window frame and on the cabinet. If either gasket is damaged, replace it per section 7.5.

7.4.4 Install a view window cover lens per Section 7.3.

7.4.5 Set the new window (cover lens down) squarely over the window opening, making sure that all edges of the window are centered and overlapping the window gasket, and that the window is resting on the lower support tabs.

7.4.6 Swing the window frame into place and tighten the frame nuts.

7.5 Window Gasket Replacement, Figure 20

7.5.1 Inspect the gaskets when changing the view window. Replace the window frame gasket and cabinet window opening gasket at the first sign of media leakage around the view window, or if gaskets are worn or otherwise damaged.

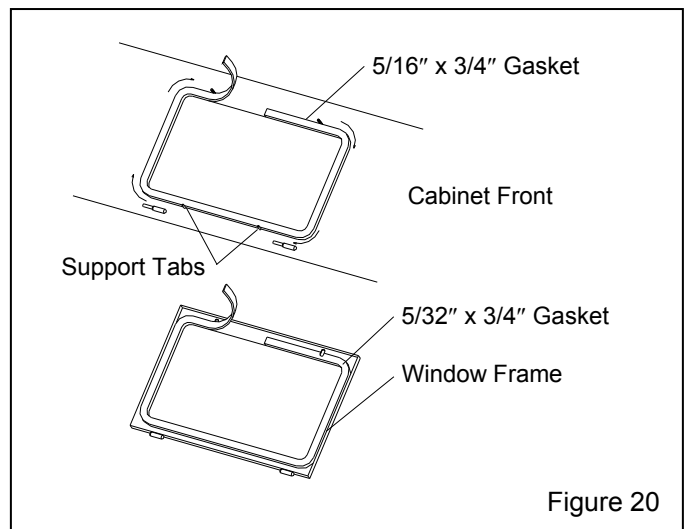

Figure 20

7.5.2 Remove the window and window frame per Section 7.6.

7.5.3 Remove all the old gasket material and clean the surfaces of the cabinet and window frame.

7.5.4 Peel a short section of adhesive backing from the 5/16"-thick strip gasket, and adhere the gasket to the center of the top edge of the window opening as shown in Figure 20. Peel additional backing as needed, and work the strip around the radius of each corner, pressing it firmly to bond. Trim the gasket to fit and compress the ends to seal.

7.5.5 Using 5/32"-thick strip gasket, repeat the process on the window frame.

7.5.6 Trim around the window frame bolt slots, as needed.

7.6 Window Frame Removal, Figure 21

7.6.1 Remove the two window frame nuts located on the upper edge of the window frame, and swing the window frame open.

7.6.2 Remove the window to prevent breakage.

7.6.3 Pivot the window frame up or down until tension is off the frame hinges.

7.6.4 To remove, slide the frame to the right. The hinges separate as shown in Figure 21.

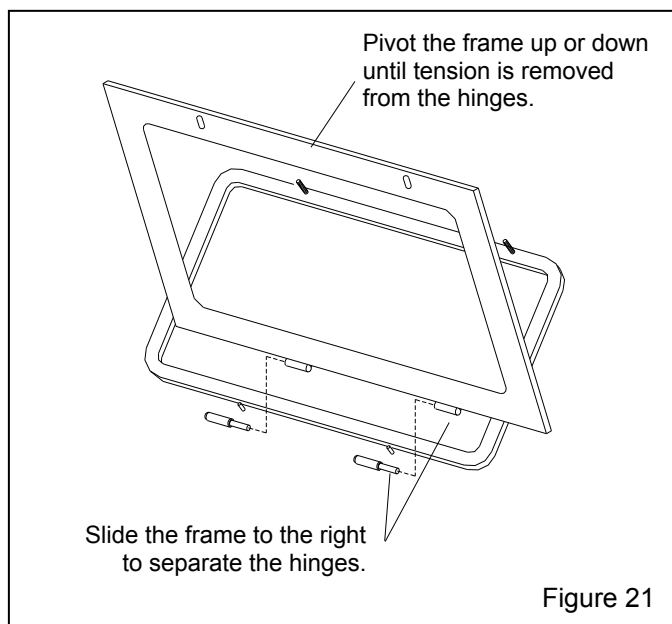

7.6.5 Replace the frame in reverse order. Align the top bolt holes with the bolts; slide the frame as necessary.

7.6.6 Set the window squarely over the window opening, making sure that all edges of the window are centered and overlapping the window gasket, and that the window is resting on the window support tabs.

7.6.7 Swing the window frame into place and tighten the frame nuts.

7.7 Light Assembly

NOTICE

Use an approved step ladder when servicing the light assembly. Do not climb on top of the cabinet. The cabinet top will not support the weight of a person.

7.7.1 Shut OFF electrical power.

7.7.2 Gasket Replacement

7.7.2.1 Remove the four wing nuts holding the light fixture to the cabinet, and use the handles to lift the fixture off the cabinet, as shown in Figure 22.

7.7.2.2 Remove all the old gasket material and clean the surfaces of the cabinet.

7.7.2.3 Lay a section of strip gasket next to the opening, and cut to length, allowing 3/4" overlap on each end. Peel a short section of adhesive backing and adhere the strip gasket to the top edge of the light opening, as shown in Figure 22. Press the gasket firmly to bond. Repeat the process for each side, compressing the ends to seal.

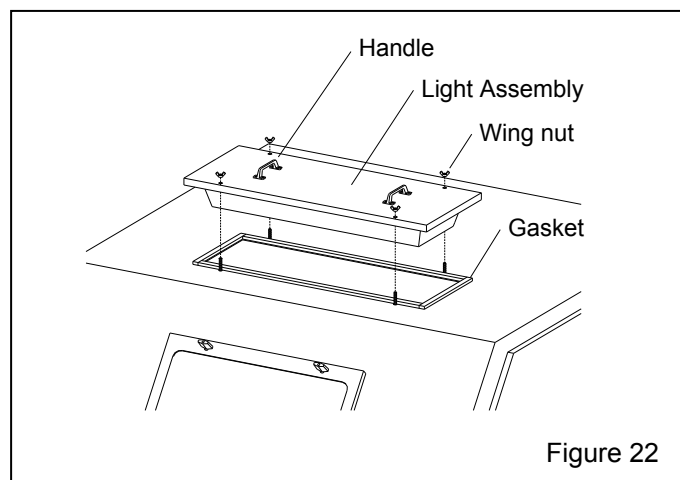

7.7.3 Lens and Tube Replacement

7.7.3.1 Remove the four wing nuts holding the light fixture to the cabinet.

7.7.3.2 Flip the fixture over to access the lens screws, ref. Figure 23.

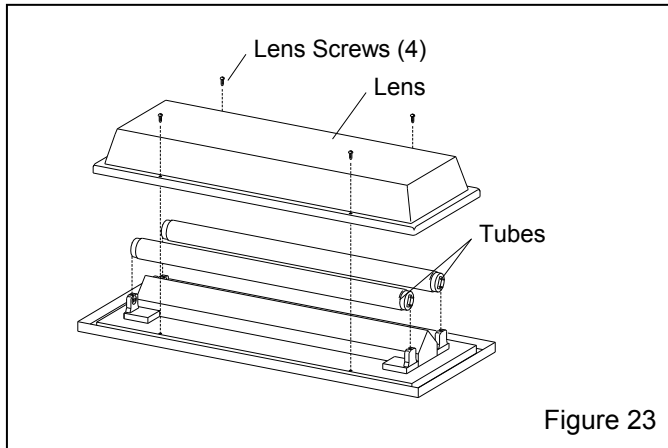

Figure 23

7.7.3.3 Remove the four lens screws and remove lens.

7.7.3.4 Replace the lens or tubes as required.

7.7.3.5 Inspect the gasket, and replace if worn or damaged.

7.7.3.6 Reassemble in reverse order.

7.8 Reclaimer Wear Plate Replacement

7.8.1 Remove the reclaimer inlet adaptor and old wear plate. The wear plate is held in place by screws attached from the outside of the reclaimer; remove the screws and pull out the wear plate from the reclaimer inlet.

7.8.2 Angle the new wear plate into the reclaimer inlet until it is in position with the straight end at the reclaimer inlet. Insert a board or similar object for leverage and pry the wear plate against the inner wall of the reclaimer. While forcing the wear plate against the reclaimer wall, install sheet metal screws through the old screw holes to secure. Caulk seams between the wear plate and reclaimer to prevent rapid wear in those areas.

7.9 Replacing or Field Installing Optional Rubber Reclaimer Liners, Figure 24 Not available for 300 cfm reclaimers.

The reclaimer must be designed to accept liners and have a removable top.

7.9.1 Remove the flex hoses from the reclaimer inlet and outlet.

7.9.2 Remove the bolts and nuts, securing the reclaimer top, and then remove the top (and top liner if the reclaimer is currently lined).

7.9.3 If the reclaimer is currently unlined, begin at the installation note preceding Paragraph 7.9.8.

7.9.4 Remove the bolts located along the side of the inlet, and remove the inlet baffle.

7.9.5 Wall liner and inlet-side extension are held in place with self-drilling screws; from the outside of the reclaimer, remove the screws. NOTE: The inlet side-liner for a 600 reclaimer is part of the wall liner, fold the straight section for side liner inward enough to remove the liner through the reclaimer top.

7.9.6 Inner cone liners and cone-ring liners are glued onto the inner cone. Pull off the liners to remove them.

7.9.7 Remove old caulking and adhesive from the weldment.

Installation NOTE: The numbers in parentheses (-) shown in Figure 24 and the applicable paragraphs, show the recommended order of installation. When installing the liners, make sure that seams are aligned. The final assembly must be smooth and free of protrusions, edges, and gaps. Any edges will disrupt the air flow, causing wear, and affect the reclaimer's media cleaning efficiency.

7.9.8 (1st) Place the cone-ring liner on the inside of the cone-ring; check fit and trim if needed. Apply medium-set contact cement to the fabric side and install the liner. NOTE: Follow the instructions provided with the adhesive, some adhesives require it to be applied to both contact surfaces. Smooth out the liner to eliminate air pockets.

7.9.9 (2nd) Place the cone liner in the cone with the fabric side down, and check the fit, trim if necessary. Follow the instructions provided with the adhesive and apply medium-set contact cement to the fabric side, and install the cone liner. Smooth out the liner to eliminate air pockets.

7.9.10 (3rd) The inlet-side and wall liner for a 600 reclaimer are one-piece. To remove the wall liner the straight inlet section must be folded inward enough to remove the liner through the top of the reclaimer. The new liner must be folded inward enough to insert it through the reclaimer top. Clamp the wall liner in place, making sure it is flush with the top of the reclaimer body and the extended inlet-side liner is aligned with the reclaimer inlet. While pushing the liner against the weldment, secure replacement liner, with self-drilling screws at each existing hole location. NOTE: To field

install a new, first-time wall liner, use self-drilling screws to secure it at the seam and an inch or two from the top and bottom at each quadrant. Clamp the side-inlet extension against the inlet side and screw it into place.

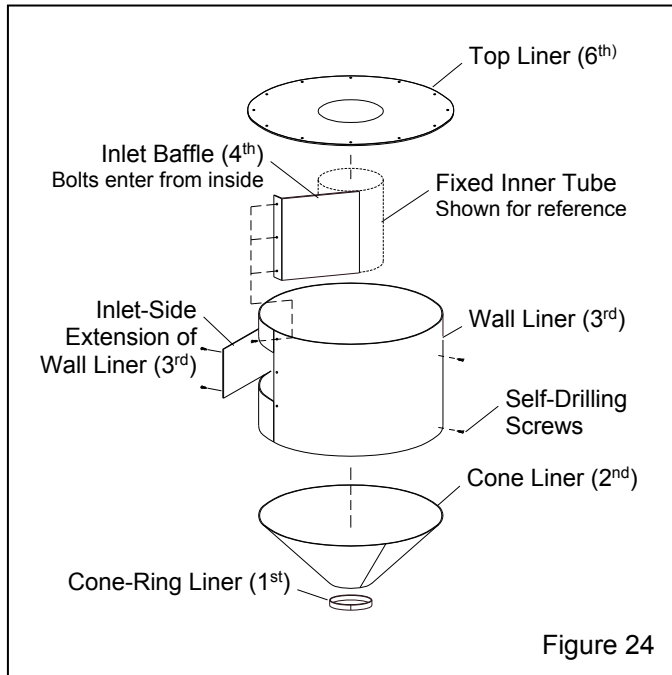

7.9.11 Apply silicone caulking to seal seams around the inlet-side liner and reclaimer weldment. Apply caulking at the seams of the cone-ring liner and cone liner and between the cone liner and wall liner. Wipe the caulking smooth.

NOTICE

All seams between each liner must be sealed, and all seams between the liners and reclaimer weldment must be sealed. Voids will cause premature wear.

7.9.12 (4th) Apply adhesive-backed strip gasket to the edge of the inlet baffle that will fit against the inner tube. Install the inlet baffle; bolts should be installed from the inside of the reclaimer to attach nuts from the outside.

7.9.13 (5th) Slide the top liner over the inner tube and align the holes in the liner with those in the top. Note that the holes around the inlet are spaced differently from the others. Temporarily install a couple of bolts to keep the alignment.

7.9.14 Align the reclaimer top assembly and lower it into place. Secure the top bolts and inlet baffle bolts.

7.9.15 Working through the reclaimer inlet, wipe the caulking seal smooth. Apply additional caulking to the seam between the baffle and wall liner. Re-caulk any voids.

7.9.16 Install flex hoses.

7.9.17 Allow time for the caulking to cure before putting the reclaimer in service

7.10 Reverse-Pulse Dust Collector

Refer to the reverse-pulse dust collector manual as shown on Page 1, Paragraph 1.1.1 for dust collector maintenance.

8.0 TROUBLESHOOTING

⚠ WARNING

To avoid serious injury, observe the following when troubleshooting.

- Turn OFF the air, and lockout and tagout the air supply.
- If checking the controls requires air, always enlist the aid of another person to:
 - Hold the blast gun securely.
 - Operate the foot pedal.
- Never bypass the foot pedal or wedge it in the operating position.
- Never override the door interlock system.

8.1 Poor visibility

8.1.1 Dirty filter cartridge(s). Pulse cartridge and empty dust container regularly. When using an RPC or RPH, refer to the reverse-pulse dust collector manual to adjust pulse pressure and pulse sequence.

8.1.2 Exhauster motor not operating. Check voltage to motor and motor wiring.

8.1.3 Check rotation of exhauster motor; the motor should rotate as indicated by the arrow on the housing. If it does not rotate in the proper direction, **lockout and tagout power** and switch the motor leads as shown on the motor plate. Refer to Section 2.5.

8.1.4 Using friable media that rapidly breaks down, or using media that is too fine or worn out.

8.1.5 Dust collector damper closed too far restricting air movement in cabinet. Adjust static pressure per Section 5.4.

8.1.6 Cabinet air-inlet damper closed too far restricting air movement through the cabinet. Adjust damper per Section 2.6 and 5.6.

8.1.7 Reclaimer door open.

8.1.8 Hole worn in flex hose between cabinet hopper and reclaimer inlet or between the reclaimer and dust collector. Replace hose and route it with as few bends as possible to prevent wear.

8.1.9 Obstruction in flex hose between the cabinet hopper and reclaimer inlet.

8.2 Abnormally high media consumption

8.2.1 Door on reclaimer open or worn door gasket. Air entering the reclaimer around the door will cause media carryover to the dust collector. DO NOT operate unless all doors are closed.

8.2.2 Dust collector ventilation damper open too far. Adjust static pressure per Section 5.4.

8.2.3 Media may be too fine or worn-out.

8.2.4 Using friable media that rapidly breaks down.

8.2.5 Blast pressure too high for the media, causing media to break down.

8.2.6 Hole worn in reclaimer or leak in reclaimer seams. Check entire reclaimer for negative-pressure leaks.

8.2.7 If using media finer than 180-mesh, the inlet baffle of the reclaimer may need to be removed. Refer to Section 1.8.6.

8.2.8 Optional externally-adjustable vortex cylinder out of adjustment. Refer to Section 5.5.

8.3 Reduction in blast cleaning rate

8.3.1 Low media level reducing media flow. Check media level and replenish or replace as needed.

8.3.2 Media/air mixture out of adjustment. Adjust metering valve per Section 5.3.

8.3.3 Reduced air pressure. This may be caused by a malfunctioning regulator, a dirty filter element in the air

filter, partially-closed air valve, leaking air line, or other air tools in use.

8.3.4 Blockage in media hose or gun. Blockage may occur as a result of a damaged or missing reclaimer screen or incorrect metering valve adjustment permitting heavy media flow. Refer to Section 5.3.

8.3.5 Worn gun parts such as nozzle or air jet. Inspect and replace all worn parts.

8.3.6 Worn media hose. Check hose for leaks and soft spots. Replace worn or damaged hose.

8.3.7 Air jet in gun out of adjustment. Check adjustment per Section 5.2.

8.3.8 Moist media. Frequent bridging or blockage in the area of the metering valve can be caused by moisture. Refer to Section 8.5.

8.4 Plugged nozzle

8.4.1 A damaged or missing reclaimer screen will allow large particles to pass and block the nozzle. Replace or reinstall as necessary.

8.4.2 Media mixture too rich. Adjust media/air mixture per Section 5.3.

8.5 Media bridging

8.5.1 Frequent bridging or blockage in the media metering valve can be caused by damp media. Media becomes damp by blasting parts that are slightly oily, or from moisture in the compressed-air line, or from absorption from ambient air.

8.5.2 To avoid contaminating media from the workpiece, all parts put into the cabinet should be clean and dry. If parts are oily or greasy, degrease and dry them prior to blasting.

8.5.3 Moist compressed air may be due to a faulty compressor that overheats, or pumps oil or moisture into the air line, too long an air line permitting moisture to condense on the inside, and from high humidity. Drain the air filter and receiver tank regularly. Ongoing problems with moist air may require the installation of an air dryer or aftercooler in the air supply line.

8.5.4 Absorption. Some media types tend to absorb moisture from the air, especially fine-mesh media in areas of high humidity. Empty the media and store it in an airtight container when cabinet is not in use.

8.5.5 A vibrator attached to the reclaimer cone or media metering valve may help to prevent bridging of fine-mesh media. NOTE: To avoid the possibility of compressing media, a vibrator should be setup to start only when the foot pedal is pressed.

8.6 Blasting does not begin when the foot pedal is pressed.

8.6.1 Door interlocks not engaging. Check adjustment per Section 5.7.

8.6.2 Blocked or leaking control lines. Check all urethane tubing for blockage or leaks.

8.6.3 Foot pedal valve malfunction. Check foot pedal alignment, and inlet and outlet lines for pressure.

8.6.4 Make sure lines are not reversed on the foot pedal or pilot regulator. Refer to the schematic on Page 26, Figure 35.

8.6.5 Pressure regulator may be set too low or OFF. Check pressure on pilot regulator.

8.6.6 Make sure that the air compressor is operating and air supply valves are open.

8.6.7 Check the nozzle to see if it is plugged. Refer to Section 8.4.

8.7 Blasting continues after the foot pedal is released

8.7.1 Make sure the 3-way valve in the foot pedal exhausts air when the pedal is released. If it does not exhaust, check the inbound air line for blockage, if no blockage, replace the valve.

8.8 Blockage in media hose

8.8.1 Media obstructions. Usually caused when the media mixture is too rich. Adjust media/air mixture per Section 5.3.

8.8.2 Wet or damp media. Refer to Section 8.5.

8.9 Media surge

8.9.1 Heavy media flow. Adjust per Section 5.3.

8.10 Poor suction in media hose

8.10.1 Inadequate air supply. Refer to the tables in Paragraphs 1.9.1 and 2.3.2 and make sure cfm and air hose requirements are met.

8.10.2 Air jet needs adjustment. Check adjustment per Section 5.2.

8.10.3 Nozzle is worn. Replace if worn 1/16" or more.

8.10.4 Blockage in media hose or nozzle. Refer to Sections 8.4 and 8.8.

8.10.5 Air jet and nozzle combination may be wrong. Refer to the table in Paragraph 1.9.1.

8.10.6 Air jet sleeve extends past end of air jet. Cut the sleeve to align with the air jet.

8.10.7 Blast pressure too high, refer to Section 5.1.

8.10.8 Nozzle inserted backward; the wider, tapered end of the nozzle should face toward the air jet.

8.11 Air only (no abrasive) from nozzle

8.11.1 Low media level in reclaimer. Check media level and replenish as needed.

8.11.2 Make sure the air hose and media hose are not reversed; the green air hose attaches to the back of the gun and the clear media hose attaches to the bottom of the gun's grip. Refer to Page 24, Figure 29.

8.12 Blow-back through media hose

8.12.1 Blockage in nozzle. Remove the nozzle and check blockage.

8.12.2 Air jet may be too large for nozzle. Refer to the table in Paragraph 1.9.1.

8.12.3 Blast pressure too high, refer to Section 5.1.

8.13 Media buildup in cabinet hopper, does not convey to reclaimer

NOTE: Do not pour media directly into the cabinet hopper, as overfilling may occur. Overfilling will result in media carryover to the dust collector and possible blockage in the conveying hose.

8.13.1 Exhauster motor rotating backwards. The motor should rotate as indicated by the arrow on the exhauster housing. If it does not rotate in the proper direction,

lockout and **tagout** electrical power and switch the motor leads as shown on the motor plate. Refer to the system's wiring schematic. Refer to Sections 2.5.1 and 2.5.2.

8.13.2 Dust collector damper closed too far restricting air movement through cabinet. Adjust static pressure per Section 5.4.

8.13.3 Dust collector filter cartridge(s) blinded. Refer to the dust collector owner's manual.

8.13.4 Hole worn in flex hose between cabinet hopper and reclaimer inlet or between the reclaimer outlet and dust collector inlet. Replace hoses and route them with as few bends as possible to prevent wear.

8.13.5 Reclaimer door open. DO NOT operate unless door is closed.

8.13.6 Obstruction flex hose. Remove hoses and check for blockage.

8.14 Static shocks

8.14.1 Cabinet and/or operator not grounded. Abrasive blasting generates static electricity. The cabinet must be earth-grounded to prevent static buildup. Refer to Sections 2.2.1 and 2.4. If shocks persist, the operator may be building up static. Attach a small ground wire, such as a wrist strap, from the operator to the cabinet.

8.14.2 Gloves wearing thin. Inspect gloves and replace them as needed.

8.14.3 Avoid holding parts off the grate. Static will build-up in the part if not dissipated through the metal cabinet.

8.15 Dust leaking from cabinet

8.15.1 Refer to Section 8.13

8.16 Dust leaking from dust collector

8.16.1 Damaged or loose filter cartridge(s). Inspect filters, replace as needed.

8.16.2 Refer to the dust collector owner's manual for operation of the dust collector

9.0 ACCESSORIES AND REPLACEMENT PARTS

9.1 Optional Accessories

Conversion kits, push-thru reclaimer to pull-thru

Description	Stock No.
Conversion kit to convert push-thru reclaimer to pull-thru. to convert from dry filter to CDC-1 dust collector Kit includes outlet adaptor pipe, gasket, and fasteners.	
for 300 cfm reclaimer	28962
for 600 cfm reclaimer	28963

Conversion kit to convert push-thru reclaimer to pull-thru. to convert from dry filter to RPC or RPH dust collector. (optional for CDC-1 for use with fine mesh media) Kit includes pull-thru adjustable vortex, gasket, and fasteners	
for 600 cfm reclaimer	28629

Description	Stock No.
20" Turntable, without bearing, 25 lb. capacity	12412

Fixed-base Turntable with Bearing, 500 lb. Capacity
Figure 25

Item	Description	Stock No.
(-)	20" dia. assembly, 500 lb. capacity	12411
1.	Turntable 20" diameter 500 lb. capacity	18329
2.	Bearing, 1-1/2" bore	11517
3.	Protector, bearing	13479
4.	Screw, 1/2-NC x 1-1/2" cap	03454
5.	Washer, 1/2" lock	03516
6.	Nut, 1/2-NC hex	03511

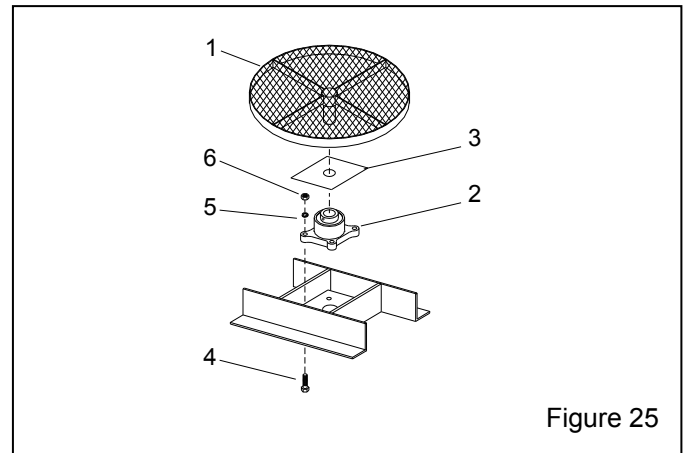

Figure 25

Table, 17.5" x 18.5", 500 lb. capacity, low-profile with inside track, table extends outside	24841
--	-------

Aluminum oxide kit: filed installed, includes light-lined flex hose, #5 boron carbide nozzle, black rubber curtains with grommets and curtain hardware. Does not include rubber reclaimer liners.

- for BNP 55 w/ 300 reclaimer12953
- for BNP 55 w/ 600 reclaimer14129

Rubber curtains, BNP 55, black

- Curtain set23530
- Back curtain14318
- Front curtain14319
- Door curtain, 2 required14320

Rubber curtains, BNP 55, white

- curtain set23540

- Time delay door locks24163
- Lock pins (pkg of 25) for twist-on hose couplings11203
- Adjusting tool, air jet19041
- Manometer kit12528
- Tumble basket, 2-gallon12227
- Anti-fatigue floor-mat, for front of cabinet24744

Reclaimer Liners, Figure 26

Reclaimer must be designed to accept liners and have a removable top.

Item	Description	Stock No.
(-)	Rubber liner sets, 600 cfm	23150
1.	Top liner, 600 cfm	22733
2.	Baffle, lined, 600 cfm	22730
3.	Wall liner, reclaimer body, 600 cfm	22731
4.	Cone liner, 600 cfm	22732
5.	Screw, self-drilling, 10-16 x 3/4"	12722

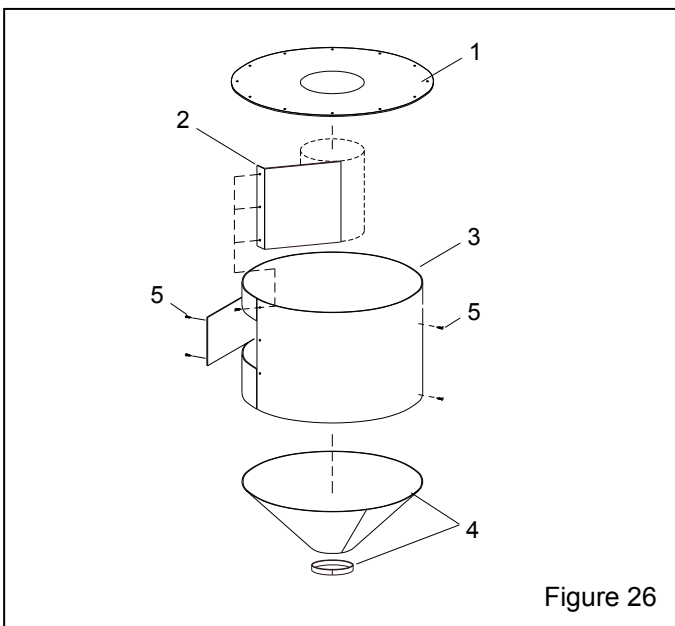

Figure 26

Extension Nozzles, Figure 27

Item	Description	Stock No.
1.	3" Straight extension nozzle No. 5, 5/16" orifice11921 No. 6, 3/8" orifice11922 No. 7, 7/16" orifice11923	
2.	6" Straight extension nozzle No. 5, 5/16" orifice11927 No. 6, 3/8" orifice11928 No. 7, 7/16" orifice11929	
3.	9" Straight extension nozzle No. 5, 5/16" orifice11924 No. 6, 3/8" orifice11925 No. 7, 7/16" orifice11926	
4.	Side-angle extension nozzle assemblies with No. 5 orifice, includes 5, 6, 7, and 8 4" long assembly21311 6" long assembly12374 9" long assembly12373	
5.	Side angle extension nozzle casing 4" long casing11943 6" long casing11940 9" long casing11939	
6.	Tip, side-angle extension12173	
7.	Snap ring, side-angle extension12040	
8.	O-ring, side-angle extension08977	

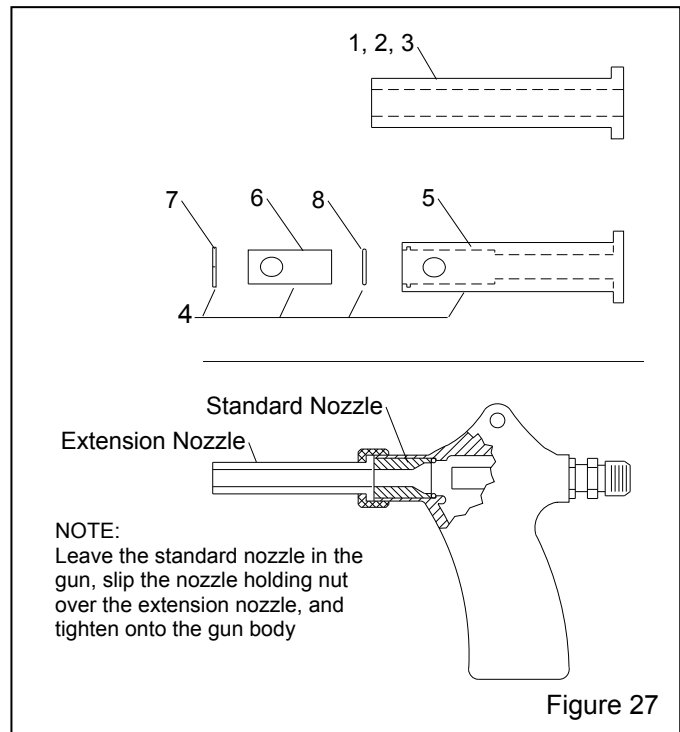

Figure 27

9.2 Cabinet Replacement Parts, Figure 28

Item	Description	Stock No.
1.	Gasket, 5/16" x 1", adhesive-backed, per foot, specify feet required Door, 8 ft. per door,.....00187 Light assembly, 7 ft. required00187 Air-inlet damper, 3 ft. required00187	
2.	Light assembly with cover23255	
3.	Door assembly, left20068	
4.	Door assembly, right20069	
5.	Grate for 5511813	
6.	Latch kit, door20064	
7.	Glove set Band-clamp attachment11215 Quick-Change (clampless attachment) ..28820	
8.	Glove, left hand only Band-clamp attachment.....12710 Quick-Change (clampless attachment) ..28638	
9.	Glove, right hand only Band-clamp attachment.....12711 Quick-Change (clampless attachment) ..28639	
10.	Clamp, glove11576	

11.	Hose, light-lined flex, specify feet required 4" ID for 300 cfm, 7 ft. required 12466 5" ID for 600 cfm, 7 ft. required 12467
12.	Clamp, flex hose for 4" hose 11577 for 5" hose 11578
13.	Grommet, media/air hose 11798
14.	Adaptor pipe universal, flex hose 4" for 300 cfm 23295 5" for 600 cfm 23296
15.	Gasket, flex hose adaptor pipe 4" for 300 cfm 23258 5" for 600 cfm 23259
16.	Actuator bracket, door interlock 19152
17.	Over-travel stop, door interlock 20004
18.	Detent sleeve, door interlock 15042
19.	Air valve, 3 way, door interlock 12202
20.	Regulator, 1/8" NPT pilot 12715
21.	Gauge, pressure 1/8" NPT cbm 01908
22.	Fitting, 1/8" NPT elbow x 1/8" barb 11733
23.	Foot pedal assembly, less tubing 20483
24.	Filter/regulator, suction piping assembly... 12763
25.	Cord with plug, 115 volt..... 11669
26.	Damper, air-inlet 23156

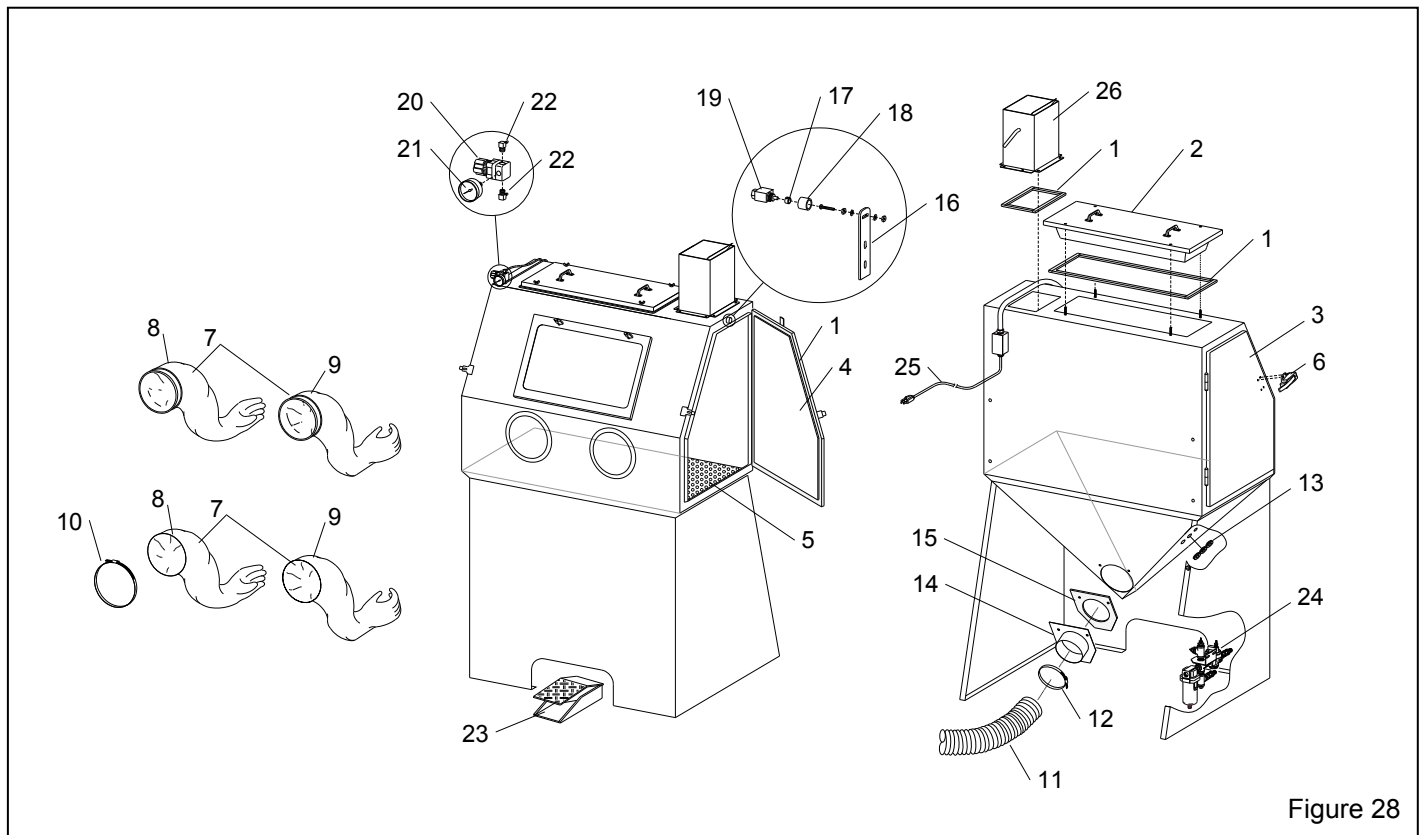

Figure 28

9.3 BNP Gun and Feed Assembly, Figure 29

Item	Description	Stock No.
(-)	BNP Gun assemblies less nozzle, includes items 1 (brass) through 7	
	No. 4 Gun	12301
	No. 5 Gun	12302
	No. 6 Gun	12303
	No. 7 Gun	12304
	No. 8 Gun	12305
1.	Nut, nozzle holding	
	Standard, knurled brass	11914
	Urethane covered	11574
2.	O-ring	08975
3.	Gun body	11802
4.	Lock nut, air jet	11913
5.	Rubber sleeve	12097
6.	Air jet assembly, includes item 5	
	No. 4	12342
	No. 5	12343
	No. 6	12344
	No. 7	12345
	No. 8	12346
7.	Fitting, hose, 3/8" NPT x 1/2" barb	06369
8.	Hose end, 1/2" barb x 1/2" fem. swivel	15002
9.	Nozzle, ceramic	
	No. 5	11930
	No. 6	11931
	No. 7	11932
	Nozzle, tungsten carbide	
	No. 5	13118
	No. 7	12882
	No. 8	11942
	Nozzle, boron carbide	
	No. 5	11935
	No. 6	11936
	No. 7	11937
	No. 8	12894
10.	Hose, 1/2" air, specify ft. required	12472
11.	Hose, media, clear, specify ft. required	12476
12.	Wide-spray nozzle	
	Tungsten carbide, No. 6	11947
	Boron carbide	
	No. 6	11934
	No. 8	11944
13.	Wide-spray nozzle nut	
	Knurled brass	11916
	Urethane covered,	12906
14.	Wide-spray retaining ring	12038
15.	Wide-spray nozzle guard	12295
16.	Adjusting tool, air jet	19041

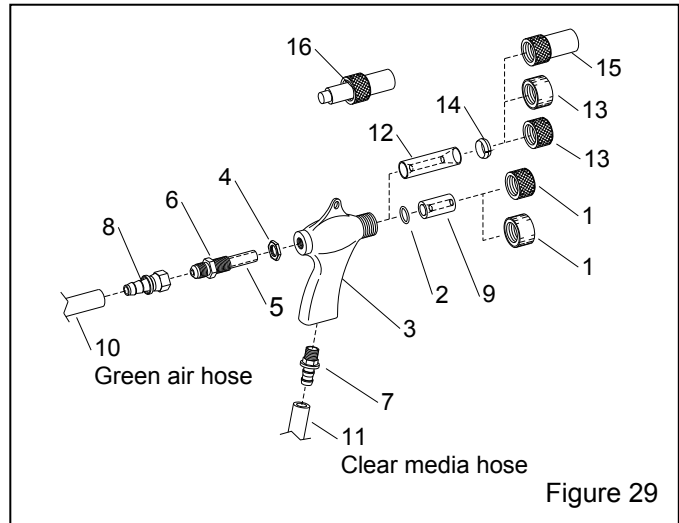

Figure 29

9.4 Suction Inlet Regulator Assembly, Figure 30

Item	Description	Stock No.
(-)	BNP Suction Regulator Assembly	
	Includes all items shown	12763
1.	Filter, 1/2" manual drain air	01308
2.	Regulator, 1/2" pilot operated pressure	11345
3.	Bracket, 1/2" regulator assembly	19231
4.	Nipple, 1/2" x 2	01734
5.	Cross, 1/2" NPT	10254
6.	Lock nut, 1/2"	12713
7.	Bushing, 1/2" NPT x 1/8"	11350
8.	Adaptor, 1/2" NPT x 1/2" flare	11351
9.	Adaptor, 1/8" NPT x 1/8" barb	11732
10.	Bushing, 1/4" NPT x 1/8" brass.....	02010
11.	Hose end, 1/2" barb x 1/2" female swivel ..	15002
12.	Tee, 1/2" NPT	01787
13.	Nipple, 1/2" x close	01733
14.	Plug 1/2" NPT	01759
15.	Nipple, 1/2" x 3	01735
16.	Screw, 1/2-NC x 1/2 set	03471

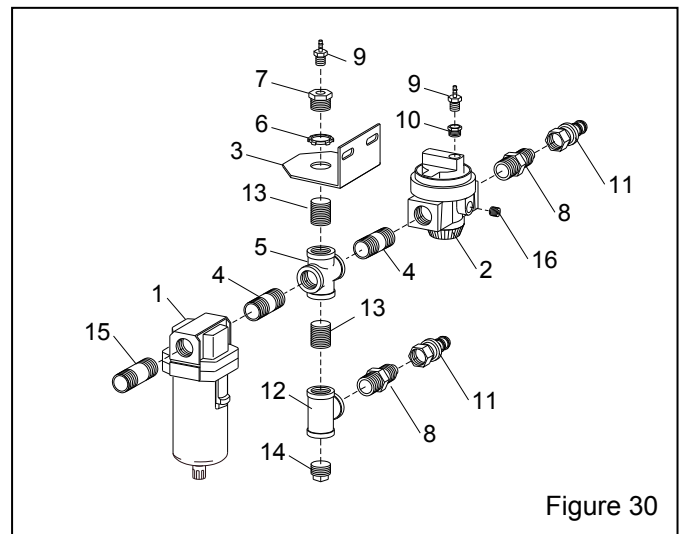

Figure 30

9.5 View Window Assembly, Figure 31

Item	Description	Stock No.
1.	Window glass, 12.5" x 19.5" laminated	12212
2.	Gasket, 5/16" x 3/4", applied to cabinet per foot, 6-feet required	00189
3.	Gasket, 5/32" x 3/4", applied to window frame per foot, 6-feet required	00192
4.	Cover lens, pkg. of 5	06190
5.	Nut, plastic, window frame, 2 required on conventional, 4 on ergo ...	23035
6.	Window frame, quick change for conventional model cabinet	22826
	for ergo model cabinet	25429

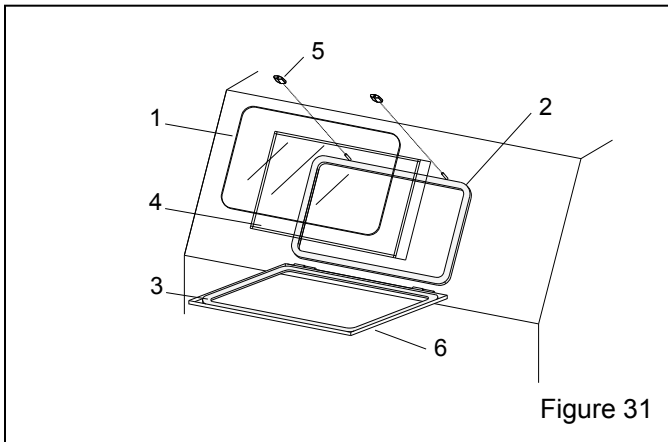

Figure 31

9.6 Light Assembly, Figure 32

Item	Description	Stock No.
(-)	Light assembly with cover	23255
1.	Light fixture (does not include cover or tubes)	24740
2.	Reflector lens	23253
3.	Tube, fluorescent, 17w	24741

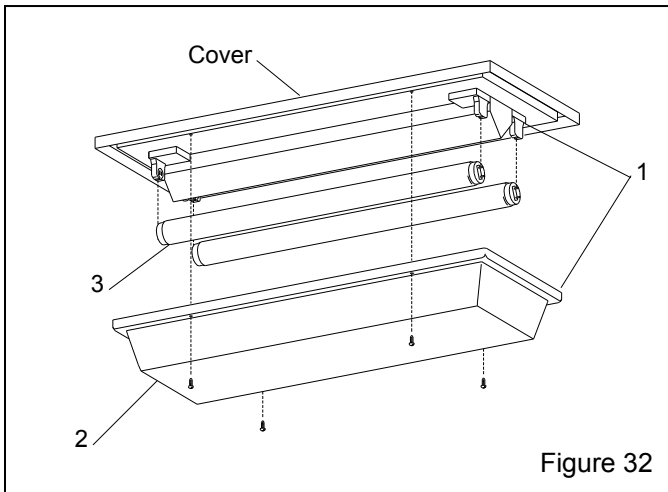

Figure 32

9.7 Foot Pedal Assembly, Figure 33

Item	Description	Stock No.
(-)	Foot pedal assembly, less tubing	20483
1.	Foot pedal casting set, top and base	28379
2.	Valve, 10-32, 3 way n/c	20026
3.	Drive pin, grooved	20109
4.	Screw, sh 1/4 NF x 3/4"	03086
5.	Screw, 10-32 x 1/2" fh	19571
6.	Adaptor, 10-32 thrd. x 1/8 barb	11731
7.	Spring, 1-1/4" x 3-1/2"	20121
8.	Screw, 8-32 x 3/8" thread cutting	11389
9.	Bumper, rubber (feet)	21522

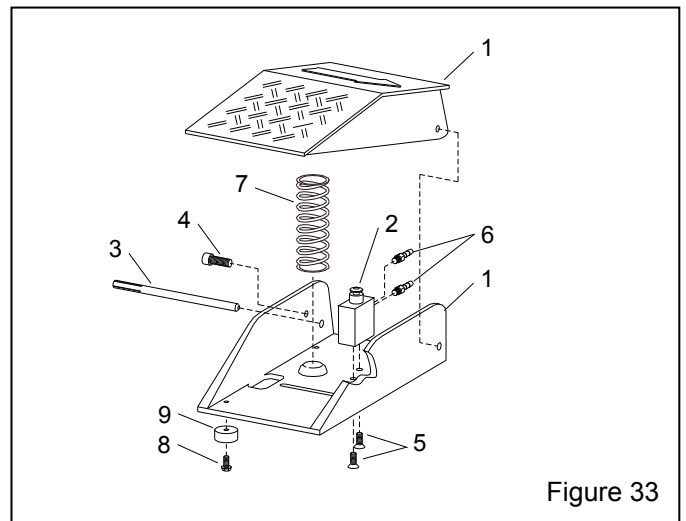

Figure 33

9.8 Metering Valve Assembly, Figure 34

Item	Description	Stock No.
(-)	Metering valve assembly	12417
1.	Metering stem assembly (items 2, 3, & 4) ..	23889
2.	Stem, metering adjusting	23097
3.	Screw, adjusting	23098
4.	Nut, adjusting stem lock	23099
5.	Body, metering valve	11532
6.	Fitting, hose, 3/8" NPT x 1/2" barb	06369
7.	Plug, metering valve	12011

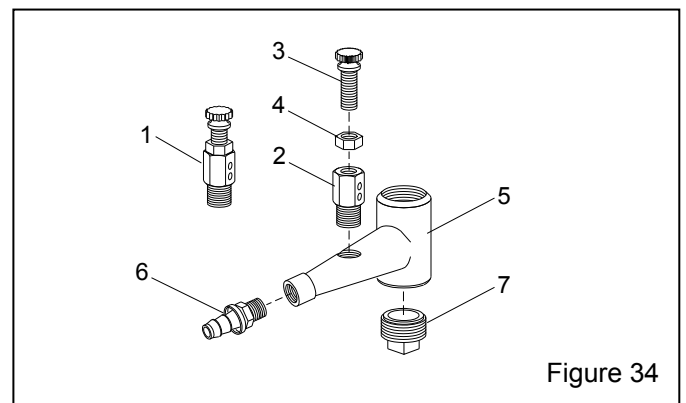

Figure 34

9.9 Cabinet Plumbing Assembly, Figure 35

Item	Description	Stock No.
1.	Valve, 3 way	12202
2.	Adaptor, 1/8" NPT x 1/8" barb	11732
3.	Tubing, 1/8" urethane, specify ft. required	12475
4.	Tubing, twin urethane, specify ft. required	19577
5.	Foot pedal assembly, less tubing	20483
6.	Fitting, 1/8" NPT elbow x 1/8" barb	11733
7.	Bushing 1/2"x 1/8" NPT	11350
8.	Bushing 1/4"x 1/8" NPT	02010
9.	Bracket, mounting	19231

10.	Filter, 1/2" air	01308
11.	Adaptor, 1/2" NPT x 1/2" flare	11351
12.	Hose end, 1/2" barb x 1/2" female swivel	15002
13.	Hose end, 1/2" barb x 3/8" male NPT	06369
14.	Blow-off nozzle	06368
15.	Air hose, 1/2", specify ft. required	12472
16.	Gun assembly, BNP No. 5	12302
17.	Hose, clear urethane, specify ft. required	12476
18.	Regulator, 1/2" pilot operated	11345
19.	Regulator, 1/8" pilot	12715
20.	Gauge, pressure	01908
21.	Metering valve assembly	12417

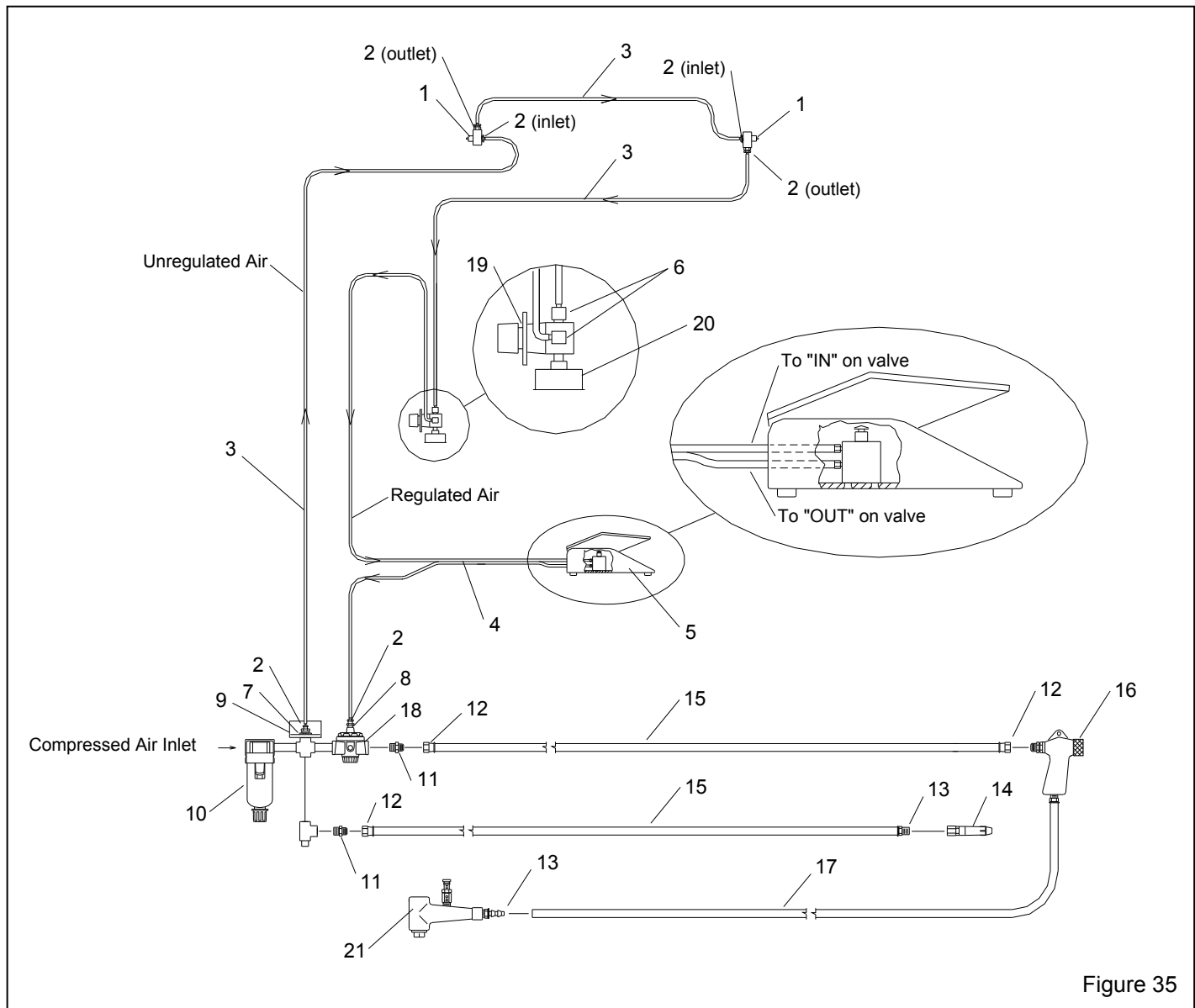

Figure 35

9.10 Reclaimer, Replacement

Replacement reclaimers are pull-thru type for use with reverse-pulse dust collectors; they include the hose inlet, screen, and wear plate, they do not include metering valve flex hoses, hose clamps, or mounting brackets. Order separately when needed.

Description	Stock No.
300 cfm reclaimer w/outlet pipe adaptor	28965
600 cfm reclaimer w/outlet pipe adaptor	28966
600 cfm reclaimer w/external adjustable vortex.....	21304

NOTE: Externally adjustable vortex cylinders are options when cabinets are provided with CDC-1 dust collectors; they are standard when cabinets are provided with an RPC or RPH dust collector.

9.11 300 and 600 CFM Reclaimer Replacement Parts, Figure 36

Item	Description	Stock No.
1.	Gasket, 5/16" x 1" adhesive-backed, per foot 3 ft. required for 300 cfm reclaimer.....	00187
	4 ft. required for 600 cfm reclaimer.....	00187
2.	Screen assembly, 8-mesh	21265
3.	Gasket, door	11745
4.	Inlet pipe adaptor 300 cfm, 4"	12365
	600 cfm, 5"	12361

5.	Gasket, inlet adaptor 300 cfm	11746
	600 cfm	11779
6.	Wear plate, rubber-lined w/mounting screws 300 cfm	14060
	600 cfm	13011
7.	Adaptor, outlet pipe 300 cfm	18475
	600 cfm	20344
8.	Spring latch assembly	12263
9.	Door assembly, w/gasket and latch	14271
*10.	Clamp, hose 4-1/2", for 4" ID hose, 300 cfm	11577
	5-1/2", for 5" ID hose, 600 cfm	11578
*11.	Hose, light-lined flex, per foot, specify length 4" ID for 300 cfm	12466
	5" ID for 600 cfm	12467
*12.	Hose, unlined flex, per foot, specify length 5" ID for 300 cfm	12449
	6" ID for 600 cfm	12452
*13.	Clamp, hose 5-1/2", for 5" ID hose, 300 cfm	11578
	6-1/2", for 6" ID hose, 600 cfm	00750
*14.	Bracket, reclaimer mount, each for BNP 55	12847
*15.	Metering valve assembly	12417
†16.	Vortex cylinder assembly, external adjust. 600 cfm	19080

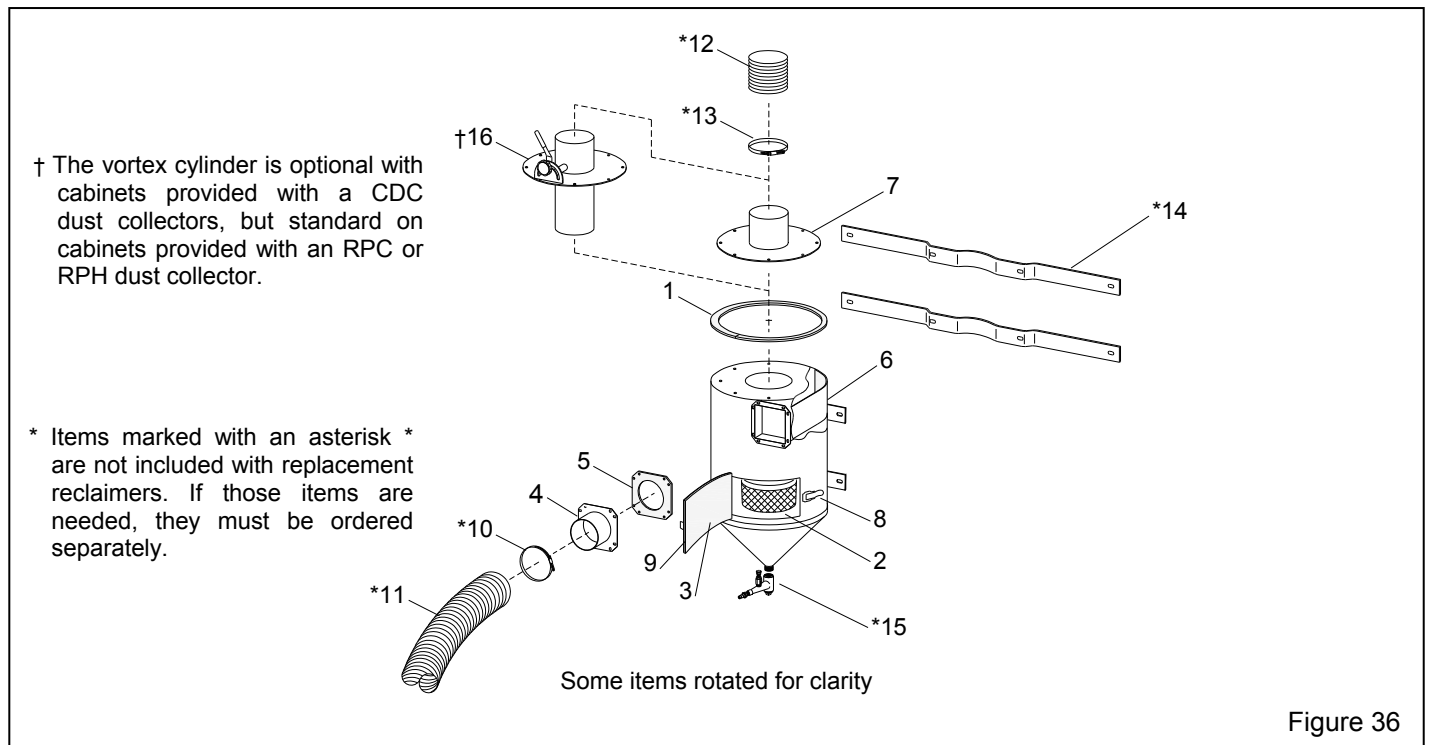

Figure 36