

**CLASSIC BLAST MACHINE  
1.5 CU. FT. TO 20 CU. FT. CAPACITY  
WITH PNEUMATIC TLR REMOTE CONTROLS  
O. M. 22501**

DATE OF ISSUE: 02/99  
REVISION: H, 07/16

 **WARNING**

**Do not use this equipment until you have READ this MANUAL and YOU UNDERSTAND its contents. \***

**These WARNINGS are included for the health and safety of the operator and those in the immediate vicinity.**

**\*If you are using a Clemco Distributor Maintenance and Parts Guide, refer to the orange warnings insert preceding the Index before continuing with the enclosed instructions.**

**Electronic files include a Preface containing the same important information as the orange cover.**

© 2016 CLEMCO INDUSTRIES CORP.  
One Cable Car Dr.  
Washington, MO 63090  
Phone (636) 239-4300  
Fax (800) 726-7559  
Email: [info@clemcoindustries.com](mailto:info@clemcoindustries.com)  
[www.clemcoindustries.com](http://www.clemcoindustries.com)



## **WARNING**

- Employers are responsible for identifying all job site hazards, educating and training all persons who will operate and maintain these products, and ensuring that all blast operators and their assistants understand the warnings and information contained in these instructions relating to safe and proper operation and maintenance of this equipment.
- Serious injury or death can result from failure to comply with all Occupational Safety and Health Administration (OSHA) regulations and all manufacturer's instructions.
- This equipment is not intended for use in any area considered hazardous per National Electric Code NFPA 70 2011, Article 500.
- Read this document and follow all instructions before using this equipment.

OSHA regulations relating to abrasive blasting are contained in the Code of Federal Regulations, Title 29 (29 CFR 1910 General Industry; 1915 Maritime; 1926 Construction). The most pertinent include: 1910.94 Ventilation, 1910.95 Occupational Noise Exposure, 1910.132 Personal Protective Equipment, 1910.133 Eye and Face Protection, 1910.134 Respiratory Protection, 1910.135 Head Protection, 1910.244 (b) Remote Controls. Consult [www.osha.gov](http://www.osha.gov) for complete information.

### **NOTICE TO PURCHASERS AND USERS OF OUR PRODUCTS AND THIS INFORMATIONAL MATERIAL**

Clemco proudly provides products for the abrasive blast industry and is confident that industry professionals will use their knowledge and expertise for the safe and efficient use of these products.

The products described in this material, and the information relating to these products, are intended for knowledgeable, experienced users.

No representation is intended or made as to: the suitability of the products described here for any purpose or application, or to the efficiency, production rate, or useful life of these products. All estimates regarding production rates or finishes are the responsibility of the user and must be derived solely from the user's experience and expertise, not from information contained in this material.

It is possible that the products described in this material may be combined with other products by the user for purposes determined solely by the user. No representations are intended or made as to the suitability of or engineering balance of or compliance with regulations or standard practice of any such combination of products or components the user may employ.

Abrasive blast equipment is only one component of an abrasive blasting job. Other products, such as air compressors, air filters and receivers, abrasives, scaffolding, hydraulic work platforms or booms, equipment for lighting, painting, ventilating, dehumidifying, parts handling, or specialized respirators or other equipment, even if offered by Clemco, may have been manufactured or supplied by others. The information Clemco provides is intended to support the products Clemco manufactures. Users must contact each manufacturer and supplier of products used in the blast job for warnings, information, training, and instruction relating to the proper and safe use of their equipment.

### **GENERAL INSTRUCTIONS**

This material describes some, but not all, of the major requirements for safe and productive use of blast machines, remote controls, respirator systems, and related accessories. All equipment and accessories must be installed, tested, operated and maintained only by trained, knowledgeable, experienced users.

The blast operator and all workers in the vicinity must be properly protected from all job site hazards including those hazards generated by blasting.

Work environments involving abrasive blasting present numerous hazards. Hazards relate to the blast process from many sources that include, but are not limited to, dust generated by blasting or from material present on the surface being blasted. The hazards from toxic materials may include, but are not limited to, silica, cyanide, arsenic, or other toxins in the abrasives or in the coatings, such as lead or heavy metals. Other hazards from toxins include, but are not limited to, fumes from coating application, carbon monoxide from engine exhaust, contaminated water, chemicals or asbestos. In addition, physical hazards that may be present include, but are not limited to, uneven work surfaces, poor visibility, excessive noise, and electricity. Employers must identify all job site hazards and protect workers in accordance with OSHA regulations.

Never modify Clemco equipment or components or substitute parts from other manufacturers for any Clemco components or parts. Any unauthorized modification or substitution of supplied-air respirator parts violates OSHA regulations and voids the NIOSH approval.

### **IMPORTANT**

Contact Clemco for free booklets:

*Blast Off 2 – Guide to Safe, Productive, and Efficient Abrasive Blasting, and Abrasive Blasting Safety Practices – Guide to Safe Abrasive Blasting.*

Clemco Industries Corp. One Cable Car Drive Washington MO 63090

Tel: 636 239-4300 — Fax: 800 726-7559

Email: [info@clemcoindustries.com](mailto:info@clemcoindustries.com)

Website: [www.clemcoindustries.com](http://www.clemcoindustries.com)

# OPERATIONAL INSTRUCTIONS

### *OPERATOR SAFETY EQUIPMENT*

## **WARNING**

- OSHA regulation 1910.134 requires appropriate respiratory protection for blast operators and workers in the vicinity of blasting. These workers must wear properly-fitted, properly-maintained, NIOSH-approved, respiratory protection that is suitable for the job site hazards. Blast respirators are to be worn only in atmospheres not immediately dangerous to life or health from which wearers can escape without use of the respirator.
- The employer must develop and implement a written respiratory protection program with required worksite- specific procedures and elements for required respirator use. The employer must provide effective training to employees who are required to use respirators. The training must be comprehensive, understandable, and recur annually, and more often if necessary.
- NEVER use abrasives containing more than one percent crystalline silica. Fatal diseases, such as silicosis, asbestosis, lead or other poisoning, can result from inhalation of toxic dusts, which include, but are not limited to, crystalline silica, asbestos, and lead paint. Refer to NIOSH Alert 92-102; and OSHA CPL 03-00-007: “National Emphasis Program – Crystalline Silica”, in which OSHA describes policies and procedures for implementing a national emphasis program to identify and reduce or eliminate health hazards from exposure to crystalline silica. Numerous topics associated with the hazards of crystalline silica in silica blasting sand can be found on [http:// osha.gov/](http://osha.gov/). Clemco urges users of silica blasting sand to visit this website, and read and heed the information it contains.
- Always make sure the breathing air supply (respirator hose) is not connected to plant lines that supply gases that include, but are not limited to, oxygen, nitrogen, acetylene, or other non-breathable gas. Never modify or change respirator air line connections without first testing the content of the line for safe breathing air. Failure to test the line may result in death to the respirator user.

- Breathing air quality must be at least Grade D, as defined by the Compressed Gas Association specification G-7.1, per OSHA Regulation 29 CFR 1910.134. When compressed air is the breathing air source, a Clemco CPF (suitable sorbent bed filter) should be used. Respirator hose connecting the respirator to the filter must be NIOSH approved. Non- approved hose can cause illness from chemicals employed to manufacture the hose.

- All workers must always wear NIOSH-approved respirators when any dust is present. Exposure to dust can occur when handling or loading abrasive, blasting, cleaning up abrasive, or working in the vicinity of blasting. Before removing the respirator, test the air with a monitoring device to ensure it is safe to breathe.

- Clemco respirators DO NOT remove or protect against carbon monoxide or any other toxic gas. Monitoring devices must be used in conjunction with the respirator to ensure safe breathing air. Always locate compressors and ambient air pumps where contaminated air will not enter the air intake.

- Always use Clemco lenses with Clemco respirators; installing non-approved lenses voids the NIOSH approval. Respirator lenses are designed to protect the wearer from rebounding abrasive; they do not protect against flying objects, heavy high-speed materials, glare, liquids, or radiation.

### *INDUSTRY ORGANIZATIONS*

For additional information, consult:

Occupational Safety and Health Administration (OSHA) - [www.osha.gov](http://www.osha.gov)  
Compressed Gas Association (CGA) - [www.cganet.com](http://www.cganet.com)  
The Society for Protective Coatings (SSPC) - [www.sspc.org](http://www.sspc.org)  
National Association of Corrosion Engineers (NACE) - [www.nace.org](http://www.nace.org)  
American Society for Testing and Materials (ASTM) - [www.astm.org](http://www.astm.org)  
National Institute of Occupational Safety and Health (NIOSH) - [www.niosh.gov](http://www.niosh.gov)  
American National Standards Institute (ANSI) - [www.ansi.org](http://www.ansi.org)

# PREFACE

## *BLAST MACHINES AND REMOTE CONTROLS*

### **WARNING**

OSHA regulation 1910.169 describes the necessity of pressure relief valves on compressed air equipment. Do not operate blast machines with air compressors that are not equipped with properly functioning pressure relief valves.

OSHA regulation 1910.244(b) requires the use of remote controls on blast machines.

Serious injury or death can result from many sources, among them:

- Involuntary activation of the remote controls. Never modify or substitute remote control parts; parts are not compatible among different manufacturers. Welding hose is not suitable for remote control hose. Its ID and material composition make it unsafe for remote control use.
- Exceeding the maximum working pressure. Clemco blast machines are built to ASME-code and carry a 'U' or 'UM' stamp, and National Board/serial number. Every machine is marked with its maximum working pressure. Never exceed the maximum working pressure limits of the blast machine.
- Uncontrolled blast stream. High-velocity abrasive particles will inflict serious injury. Always point the blast nozzle in the direction of the blast surface only. Keep unprotected workers out of the blast area.
- Welding on the blast machine. Never weld on the blast machine; welding voids the National Board approval and may affect the dimensional integrity of the vessel.
- Moving the blast machine. Never manually move a blast machine containing abrasive, any machine containing abrasive must be moved with appropriate mechanical lifting equipment.

## *HOSES, COUPLINGS, AND NOZZLE HOLDERS*

- The inside diameter (ID) of air hoses, fittings, and connections should be at least four times larger than the nozzle orifice size. Blast hose ID should be three to four times the size of the nozzle orifice. Example: a #6 nozzle (3/8" diameter orifice) calls for 1-1/2" ID blast hose and 1-1/2" ID or larger compressor hose. All hose runs should be kept as short as possible and run in as straight a line as possible to reduce pressure loss.
- To install, squarely cut the end of the hose so that it fits snugly against the coupling or hose end shoulder. Always use the screws recommended by the manufacturer ensuring that they do not penetrate the inner wall. Make sure the couplings tightly fit the hose. Install cotter pins at every connection or use couplings with built-in lock-springs to prevent disengagement. Install safety cables at all connections to prevent whipping if hoses disengage or blow out.

## *MAINTENANCE AND REPAIR*

- Completely read and follow all service instructions and recommended maintenance intervals. Always shut off compressor and depressurize blast machine before performing any maintenance. At every service interval, clean all filters, screens, and alarm systems. If spring-loaded abrasive valves are used, always cage spring before disassembly.

## *WARRANTY*

The following is in lieu of all warranties, express, implied or statutory, and in no event shall seller or its agents, successors, nominees or assignees, or either, be liable for special or consequential damage arising out of a breach of warranty. This warranty does not apply to any damage or defect resulting from negligent or improper assembly or use of any item by the buyer or its agent or from alteration or attempted repair by any person other than an authorized agent of seller. All used, repaired, modified, or altered items are purchased "as is" and with all faults. In no event shall seller be liable for consequential or incidental damages. The sole and exclusive remedy of buyer for breach of warranty by seller shall be repair or replacement of defective parts or, at seller's option, refund of purchase price, as set forth below

1. Seller makes no warranty with respect to products used other than in accordance hereunder.
  2. On products seller manufactures, seller warrants that all products are to be free from defects in workmanship and materials for a period of one year from date of shipment to buyer, but no warranty is made that the products are fit for a particular purpose.
  3. On products which seller buys and resells pursuant to this order, seller warrants that the products shall carry the then standard warranties of the manufacturers thereof, a copy of which shall be made available to the customer upon request.
  4. The use of any sample or model in connection with this order is for illustrative purposes only and is not to be construed as a warranty that the product will conform to the sample or model.
  5. Seller makes no warranty that the products are delivered free of the rightful claim of any third party by way of patent infringement or the like.
  6. This warranty is conditioned upon seller's receipt within ten (10) days after buyer's discovery of a defect, of a written notice stating in what specific material respects the product failed to meet this warranty. If such notice is timely given, seller will, at its option, either modify the product or part to correct the defect, replace the product or part with complying products or parts, or refund the amount paid for the defective product, any one of which will constitute the sole liability of the seller and a full settlement of all claims. No allowance will be made for alterations or repairs made by other than those authorized by seller without prior written consent of seller. Buyer shall afford seller prompt and reasonable opportunity to inspect the products for which any claim is made as above stated.
- Except as expressly set forth above, all warranties, express, implied or statutory, including implied warranty of merchantability, are hereby disclaimed.

# PREFACE

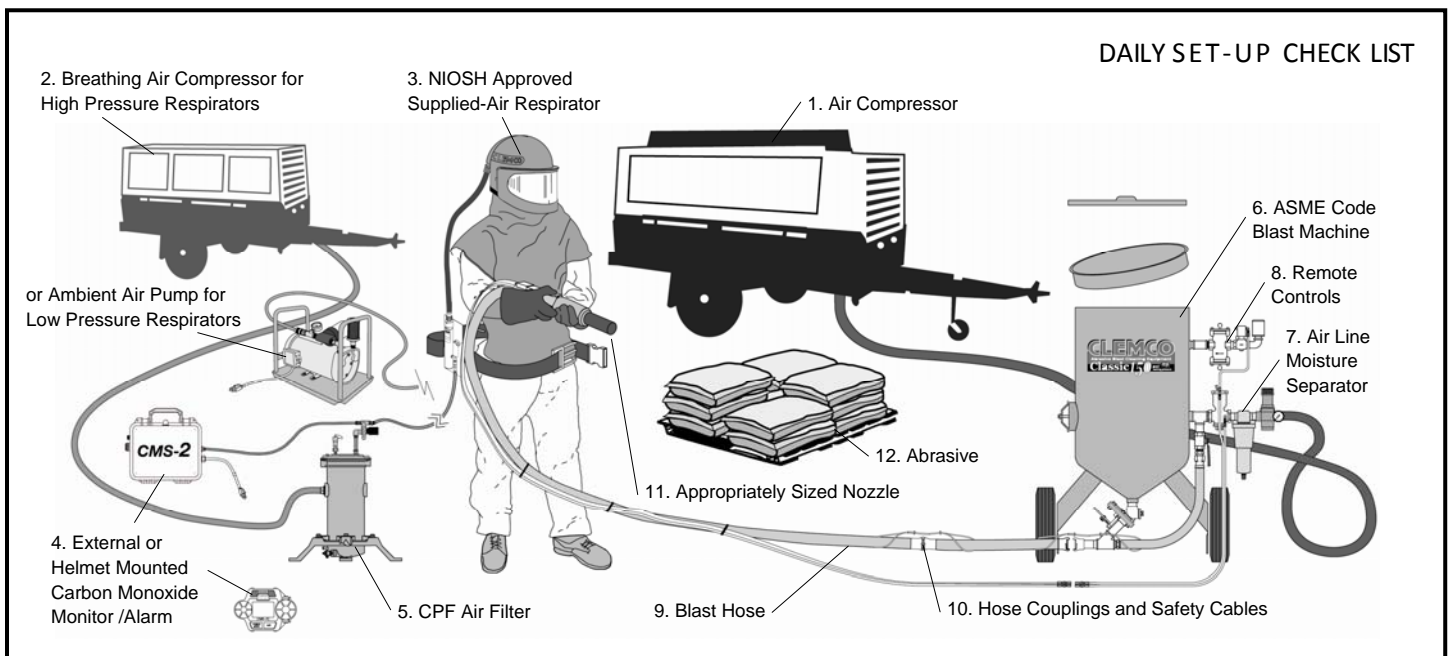

DAILY SET-UP CHECK LIST

Make sure all blast operators are properly trained and suitably attired with a blast suit, safety boots, leather gloves, respiratory and hearing protection. Every day before start up, check all equipment components, including piping, fittings, and hoses, and valves, for leaks, tightness, and wear. Repair or replace as needed. Use the following checklist.

- 1. PROPERLY-MAINTAINED AIR COMPRESSOR** sized to provide sufficient volume (cfm) at given pressure for nozzle and other tools. ADD 50% volume (cfm) reserve to allow for nozzle wear. Use large compressor outlet and air hose (at least 4 times the nozzle orifice diameter). For oil-lubricated compressors, the employer shall use a high-temperature or carbon monoxide alarm, or both, to monitor carbon monoxide levels. If only high-temperature alarms are used, the air supply shall be monitored at intervals sufficient to prevent carbon monoxide in the breathing air from exceeding 10 ppm. Follow the manufacturer's checklist and maintenance instructions.
- 2. BREATHING-AIR COMPRESSOR** (or oil-less ambient air pump) capable of providing Grade D quality air, located in a dust free area. Read # 1 above.
- 3. CLEAN, PROPERLY-MAINTAINED NIOSH-APPROVED SUPPLIED-AIR RESPIRATOR** worn by blast operators, and other workers exposed to blast dust. Make sure all respirator components are in place — all lenses, inner collar, and cape. Thoroughly inspect all components for wear. The NIOSH approval (approval number is listed in the owner's manual) is for a complete assembly from point of attachment on the CPF (sorbet bed) filter to the complete respirator. Substitution of any part voids the NIOSH approval.
- 4. CARBON MONOXIDE MONITOR/ALARM** installed at the CPF filter or inside the supplied-air respirator for monitoring for the presence of deadly CO gas and warning the operator(s) when the CO level reaches an unacceptable level. When an ambient air pump is used for breathing air, a CO monitor provides a measure of safety. Read # 1 above.
- 5. BREATHING-AIR FILTER (OSHA-REQUIRED sorbet bed filter)** for removal of moisture and particulate matter in the compressed air breathing-air supply. Monitor the condition of the cartridge and replace when odor is detected or at 3 month intervals, whichever comes sooner. The breathing air filter does NOT detect or remove carbon monoxide (CO). Always install a CO monitor/alarm.
- 6. BLAST MACHINE** (bearing U or UM stamp, National Board Number, and Maximum Working Pressure) sized to hold a 30-minute abrasive supply. Examine pop-up valve for alignment. Check piping, fittings, screens, valves for tightness, leaks, and wear. Always ground the machine to eliminate hazard of static shock. Install a blast machine screen to keep out foreign objects. Use a blast machine cover if left outdoors overnight. Never exceed the maximum working pressure of the vessel.
- 7. AIR LINE FILTER** (moisture separator) installed as close as possible to the blast machine inlet and sized to match the size of the inlet piping or larger air supply line. Clean filter and drain often. Damp abrasive causes operational problems.
- 8. REMOTE CONTROLS** are required by OSHA and must be in perfect operating condition. Test and check all components to ensure all parts are present and fully functional. Use genuine replacement parts. NEVER mix parts from different manufacturers. Never use welding hose for remote control hose.
- 9. BLAST HOSE** should have an inside diameter sized to suit the blast nozzle. The ID should be three to four times the size of the nozzle orifice diameter. Blast hose should be arranged in as straight a line as possible from the blast machine to the work area, avoiding sharp bends.
- 10. COUPLINGS AND NOZZLE HOLDERS** should fit snugly on the hose and be installed with manufacturer recommended screws. Coupling lugs must snap firmly into locking position. Gasket must always be used to form a positive seal, and cotter pins must be installed. Replace gasket when wear, softness or distortion is detected. Check nozzle holder for thread wear; replace at any sign of wear. Install safety cables at all connections.
- 11. NOZZLE** orifice size should be checked and nozzle replaced when worn 1/16" from original size. (No. 5 nozzle has 5/16" orifice diameter; replace when it measures 3/8"). Threads should be inspected daily for wear and nozzle should be replaced when wear is detected. Always use a nozzle washer.
- 12. ABRASIVE** must be a material specifically manufactured for blasting. It should be properly sized for the job. Check material safety data sheet for free-silica, cyanide, arsenic, lead and other toxins and avoid use when these toxic, harmful substances are present.
- SURFACE TO BE BLASTED** should be examined for hazardous substances. Take appropriate protective measures as required by OSHA to ensure the blast operator, other workers in the vicinity, and any bystanders are properly protected.

**1.0 INTRODUCTION**

**1.1 Scope of manual**

**1.1.1** This manual covers installation, operation, maintenance, troubleshooting, and replacement parts for Clemco blast machines ranging in size from 1.5 cu ft. through 20 cu ft. with TLR-100/300, and TLR-100/300D pneumatic remote controls and standard FSV abrasive metering valve. These instructions also contain important safety information required for safe operation of the machine. The following separate instruction manual is provided for the remote control handle.

RLX control handle .....Manual No. 10574

**NOTE:** Separate operation instructions are included when optional valves are provided.

The optional abrasive cut-off system (ACS) uses a pneumatically-operated abrasive metering valve. Separate operation instructions are included for the metering valve when ACS systems are provided.

**1.1.2** This manual contains important safety information. All operators and personnel involved with the abrasive blast process must read and understand the contents of these instructions, including the orange cover. It is equally important that the operator is trained and qualified to safely operate the blast machine and remote controls and all other equipment used with the blast machine.

**1.1.3** All personnel involved with the abrasive blasting process must be made aware of the hazards associated with abrasive blasting. The Clemco booklet "Abrasive Blasting Safety Practices" is included with every blast machine; It contains important safety information about abrasive blasting that may not be included in equipment operation manuals. The booklet is available in both English and Spanish; to request copies, email [info@clemcoindustries.com](mailto:info@clemcoindustries.com).

**1.2 Safety Alerts**

**1.2.1** Clemco uses safety alert signal words, based on ANSI Z535.4-2011, to alert the user of a potentially hazardous situation that may be encountered while operating this equipment. ANSI's definitions of the signal words are as follows:



**This is the safety alert symbol. It is used to alert you to potential physical injury hazards. Obey all safety messages that follow this symbol to avoid possible injury or death.**

**NOTICE**

**Notice indicates information that is considered important, but not hazard-related, if not avoided, could result in property damage.**

**CAUTION**

**Caution indicates a hazardous situation that, if not avoided, could result in minor or moderate injury.**

**WARNING**

**Warning indicates a hazardous situation that, if not avoided, could result in death or serious injury.**

**DANGER**

**Danger indicates a hazardous situation that, if not avoided, will result in death or serious injury.**

**1.3 Components and Operating Principles**

**1.3.1 Components**

**1.3.1.1** The primary components of the blast machine and the remote control system are shown in Figure 1. Additional components of the remote controls are shown in Figure 2. Additional parts used with optional ACS abrasive cut-off system are shown in Figure 5.

**1.3.2 Blast Machine**

**1.3.2.1** Clemco blast machines (pressure vessels) are certified to conform to the ASME (American Society of Mechanical Engineers) Boiler and Pressure Vessel Code, Section VIII, Division 1. It is the owner's responsibility to maintain the integrity of the vessel in accordance with the requirements of state regulations. Regulations may include regular inspection and hydrostatic testing as described in National Board inspection code and jurisdictional regulations and/or Laws.

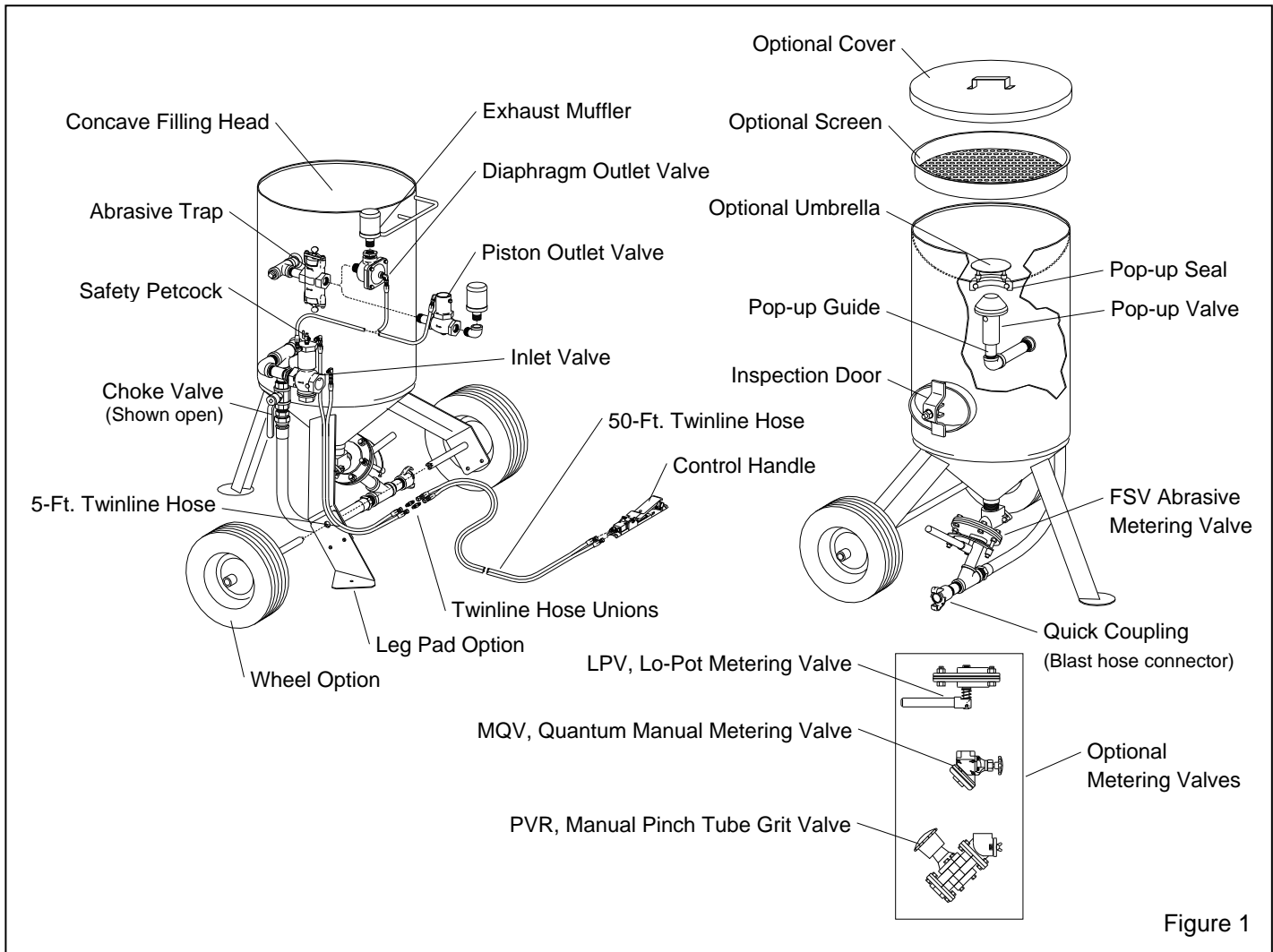

Figure 1

**⚠ WARNING**

**Welding, grinding, or drilling on the blast machine could weaken the vessel. Compressed air pressure could cause a weakened blast machine to rupture, resulting in death or serious injury. Welding, grinding, or drilling on the vessel, without a National Board R stamp, voids the Clemco ASME certification.**

**1.3.2.2** All welding repairs to the vessel must be performed by certified welders at shops holding a National Board R Stamp. Welding performed by any welder not properly qualified per the ASME code voids the Clemco ASME certification.

**1.3.2.3** Do not exceed the maximum working pressure rating (PSI) of the blast machine. The maximum pressure rating is stamped into ASME nameplate which is welded to the side of the vessel.

**⚠ WARNING**

**Excessive compressed air pressure could cause a blast machine to rupture. To prevent serious injury or death, do not exceed the rated pressure of the blast machine.**

**1.3.2.4** OSHA does not require pressure relief valves on blast machines when air compressors supplying air to the blast machines are built to ASME<sup>(1)</sup> code and comply with OSHA<sup>(2)</sup> regulations. OSHA regulation 1910.169 refers to the ASME code when describing the necessity of pressure relief valves on compressed air equipment. **DO NOT** operate blast machines with air compressors that are not equipped with properly-functioning pressure relief valves.

<sup>(1)</sup> American Society of Mechanical Engineers, Boiler and Pressure Vessel Code, Section VIII, Division 1,

<sup>(2)</sup> Occupational Safety and Health Administration, 29 CFR 1910, 169.

1.3.3 Remote Controls

**⚠ WARNING**

**Never modify or substitute remote control parts. Parts from other manufacturers are not compatible with Clemco equipment. If ANY part of the remote control system is altered, involuntary activation could occur, causing serious injury.**

1.3.3.1 A remote control system is an OSHA-required safety device; it is required when an operator mans the nozzle. The remote controls allow the blast operator to pressurize the machine to start blasting, and depressurize it to stop blasting, at the nozzle.

1.3.3.2 The control handle, located near the blast nozzle, is the activator for the remote control system. When the operator intentionally or unintentionally removes hand-held pressure from the control handle, the machine depressurizes and blasting stops. The remote control system “fails to safe”, which means when an interruption in the control-air circuit occurs for reasons such as a break in the line, the compressor stops running, or the operator drops the blast hose, the

remote control deactivates the blast machine and blasting stops.

1.3.3.3 The components of the remote control system are shown in Figures 1 and 2. They include the inlet valve, piston or diaphragm outlet valve (the piston valve is used in most applications, the diaphragm valve is recommended for use with fine mesh or aggressive abrasive), RLX control handle, 50-ft. and 5-ft. long twinline control hoses, 2 control hose unions, and an 18-inch-long interconnecting hose.

**⚠ WARNING**

**Moist air that freezes could cause blockage at the control handle or in the control lines. Blockage could cause involuntary activation of the remote controls, or prevent the controls from deactivating upon release of the control handle. This situation could result in serious injury or death. If remote controls are operated in freezing or near-freezing weather, install a Clemco Anti-Freeze Injector, stock no. 05537, on the remote control air-supply line.**

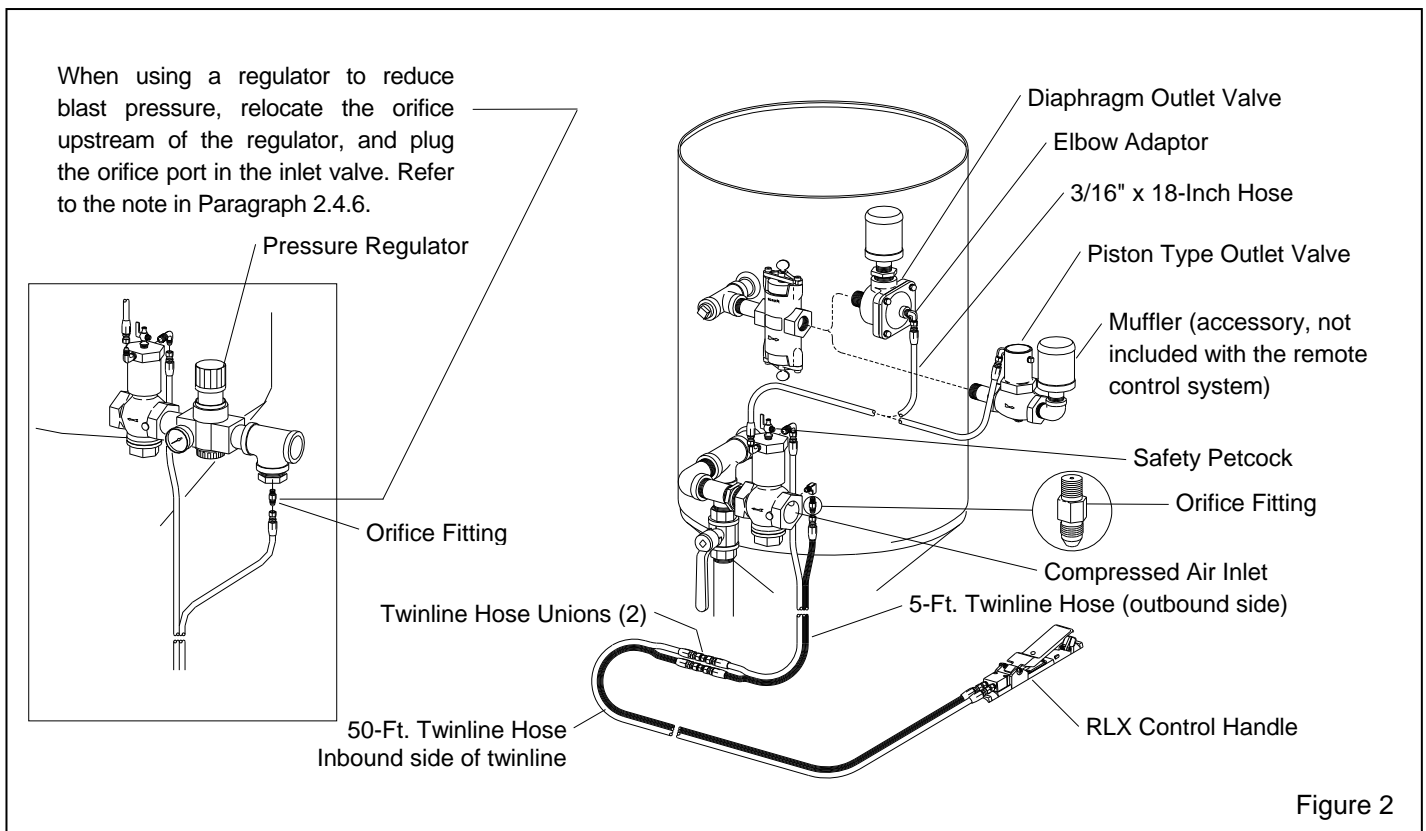

Figure 2



**1.3.3.4** TLR Remote Controls are pressure-release-style systems, which control the pressurization and depressurization of the blast machine. Pressurization, which starts blasting, occurs when the control handle is pressed, and depressurization, which stops blasting, occurs when the handle is released.

**1.3.3.5** Clemco remote controls operate pneumatically on a return-air principle. A stream of control air travels from the orifice on the inlet valve, down the outbound twinline (Shown shaded in Figure 2) and escapes through the opening located under the control handle lever. The normally-closed inlet valve remains closed, and the normally-open outlet valve remains open. As long as air escapes through the handle's opening, the remote control system remains inactive. When the lever is pressed, a rubber button seals the opening, and outbound air returns through the inbound line to open the inlet valve and close the outlet valve. This action pressurizes the blast machine and begins the blasting. Releasing the handle exhausts the control air, which causes the inlet valve to close, and the outlet valve to open to depressurize the blast machine and stop the blasting.

### **1.3.4 Abrasive Cut-off (ACS) Option**

**1.3.4.1** The abrasive cut-off switch is mounted on the control handle. It closes the metering valve so that air alone, without abrasive exits the nozzle. This feature is used to clear the blast hose and to blow-down the blast surface.

**NOTE:** The ACS feature requires a pneumatically-operated abrasive metering valve. It is not available on Lo-Pot blast machines, which do not have adequate clearance for the metering valve.

**1.3.4.2** Parts used with an optional ACS system are shown in Figure 5. In addition to the standard remote controls, an ACS system also includes a 50-ft. single-line hose, and additional 18-inch-long interconnecting hose, an RLX control handle with ACS air switch assembly, and pneumatically-operated metering valve. The metering valve supplied with the system may differ from the one shown. **NOTE:** A separate owner's manual is supplied with the valve.

### **1.3.5 Electric Control Option**

**1.3.5.1** Electric remote controls (electro-pneumatic) are recommended when the nozzle and remote control handle are farther than 100 feet from the blast machine. Pressure drop of pneumatic systems over longer distances increases response time, which prevents fast, safe operation. Contact your local Clemco Distributor for additional information.

## **1.4 Abrasive**

### **WARNING**

**Obtain Safety Data Sheets (SDS) for the blast abrasive. Abrasive blasting with sands containing crystalline (free) silica can lead to serious or fatal respiratory disease. As NIOSH recommends, do not use abrasives containing more than trace amounts (more than one percent) free silica.**

**NOTE:** Use only abrasives specifically manufactured for blasting, that are compatible with the surface being blasted. Abrasive produced for other applications may be inconsistent in size and shape, and contain particles that could jam the abrasive metering valve, or cause irregular wear.

**1.4.1** Selection of blasting abrasive can play a significant part in the health risk, productivity, and maintenance of the blast machine. **DO NOT USE** abrasives containing more than one percent crystalline (free) silica. Obtain safety data sheets (SDS) for the blasting abrasive prior to blasting, paying particular attention to the health risks and presence of any hazardous/toxic substances.

**1.4.2 Abrasive Size:** The choice of abrasive size depends on the desired profile, cleaning rate, nozzle size and availability of clean dry air. Generally, larger and denser abrasives provide a deeper profile, while smaller abrasives clean faster. Most abrasive blasting is done with abrasive sizes between 16 and 80 mesh. Larger sizes may be used if the nozzle orifice is large enough to prevent particles to pass without jamming. Finer abrasive is especially sensitive to moisture and requires very dry air to prevent bridging in the metering valve.

**1.4.3 Sand:** Sand should never be used because of the respiratory hazards associated with abrasives containing free silica.

**1.4.4 Slags:** Slag abrasives are compatible with the blast machine and accessories. Obtain safety data sheets (SDS).

**1.4.5 Steel:** Steel shot and steel grit may be used with machines fitted with an optional Quantum or manual PVR pinch-tube metering valve. Optional valves are shown in Section 7.5. Shot applications may require the use of a pneumatically-operated metering valve such as the Sentinel or Auto-Quantum, to prevent surging at startup.

**1.4.6 Silicon Carbide, Aluminum Oxide, and Garnet:** These are the most aggressive, high-volume abrasives in the blasting industry. Aggressive abrasives such as these may be used, but the service life on any equipment components which come in contact with the abrasive will be reduced. Use a nozzle lined with boron carbide with these abrasives.

**1.4.7 Glass Bead:** Most beads are treated to ensure free-flow operation even under moderately high-humidity. Glass beads subjected to excessive moisture may be reused after thorough drying and breaking up of any clumps. Clean, dry air is a necessity. Glass bead applications may require the use of a pneumatically-operated metering valve, such as the Sentinel or Auto-Quantum, which can help to prevent surging at startup.

**1.4.8 Lightweight Abrasive:** Plastic media and most agricultural media may occasionally be used in a standard blast machine. Exclusive use of plastic, and some lightweight media, requires a blast machine with a 60° conical bottom to maintain continuous media flow.

**2.0 INITIAL SET-UP**

**2.1 Storage Hopper**

**2.1.1** When a storage hopper is installed above the blast machine, an umbrella, mounted above the pop-up opening is required. Refer to Section 7.5, Item 22 for optional bolt-on umbrella.

**2.2 Set Up for Multiple Blast Machines Operating From a Common Compressed Air Supply**

**⚠ CAUTION**

If multiple machines are operating from a common compressed air supply, and a machine is under pressure, when another machine is pressurized, the sudden, increased demand for air could reverse air flow from the machine that is under pressure, and contaminate the compressed air supply with abrasive-laden air. Install check valves at the piping inlet to prevent the reversal of air.

**2.2.1** Where multiple blast machines are operating from a single air source, install a ball-cone check valve at the air supply on each machine. Refer to the illustration in Figure 3 to install a check valve on a blast machine.

**2.2.2** If the machines are placed close together, use a receiver tank or manifold and run separate air lines from it to each machine. The check valves may be located on the receiver tank outlets if the air line goes directly to the blast machine and nowhere else.

Note: Do not use a swing check valve, as the swing gate may break in blast machine applications. When installing the valve, make sure the directional arrow is pointing in the direction of the air flow (toward the machine).

**2.2.3** Use a Clemco ball-cone check valve shown below. A smaller-size valve could restrict air movement and reduce nozzle pressure.

- TLR-100 with 1-NPT inlet valve  
use 1-1/4-NPT check valve ..... Stock No. 02088
- TLR-300, with 1-1/2-NPT inlet valve  
use 1-1/2-NPT check valve ..... Stock No. 02296

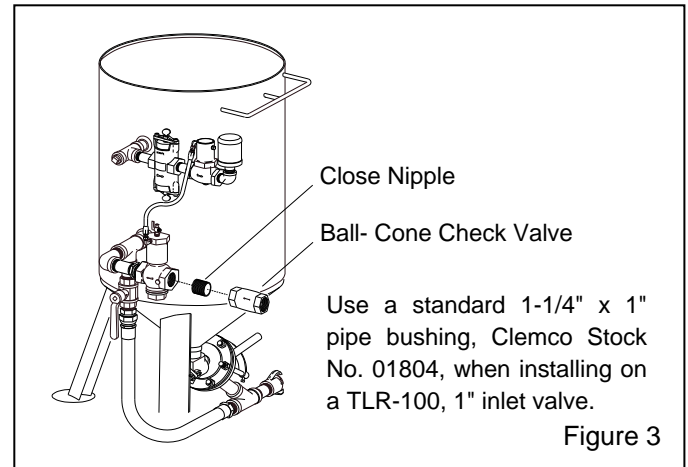

**2.3 Blast Machine Set-Up**

**⚠ WARNING**

Clemco supplies an exhaust muffler with all blast machines of 2 cu. ft. capacity and larger. The muffler reduces exhaust noise and prevents abrasive from exhausting upward or sideways into the air. When the blast machine is depressurized, the muffler body pops up to diffuse the air and abrasive. When the machine is fully depressurized, the muffler body drops, permitting trapped abrasive to empty. For the muffler to work properly, it must be installed with the body facing up, as shown in Figure 1.

If an application requires the muffler to be removed, the exhaust piping must be plumbed to direct exhausting air in a direction that ensures no persons will be exposed to high velocity air and abrasive, which escapes when the blast machine is depressurized.

**2.3.1** Install an optional filter (moisture separator) to the inlet valve. The filter is recommended at this location to remove condensed moisture from air before it enters the machine.

**2.3.2** Install an air-supply hose fitting to the inlet valve (or air filter), that is compatible with the compressed-air supply hose. NOTE: For best blasting performance, the ID of the air-supply hose should be at least 4 times the diameter of the nozzle orifice. A smaller diameter hose could result in a reduction in nozzle pressure. Refer to the table in Paragraph 3.2.2.

#### 2.4 Prepare Blast Hose and Remote Control Hose Connections.

When installing the Optional ACS feature, refer to Section 2.5 for additional instructions.

### **⚠ WARNING**

Where two or more blast machines are used in close proximity, care must be taken when tracing and connecting control lines and blast hose. Cross connecting control hose or blast hose could lead to serious injury, death, or property damage from unintentional actuation of a blast machine. To prevent cross connecting blast hose and control hose, the hoses should be of equal lengths and the hoses and blast machine couplings clearly marked, using optional hose identification kits, stock no. 15890 for use with two blast machines, or stock no. 15891, for up to four machines. Mark each hose and corresponding connection per the instructions supplied with the kit, and carefully trace and verify each connection before operating.

### **⚠ WARNING**

Moist air that freezes could cause blockage at the control handle or in the control lines. Blockage could cause involuntary activation of the remote controls, or prevent the controls from deactivating upon release of the control handle. This situation could result in serious injury or death. If remote controls are operated in freezing or near-freezing weather, install a Clemco Anti-Freeze Injector, stock no. 05537, on the remote control air-supply line.

Note: Control hoses come with reusable hose ends. Excess hose may be cut-to-fit and recoupled, refer to Section 5.11.

**2.4.1** Uncoil the blast hose and lay the 50-foot twinline hose alongside it.

**2.4.2** Band the control handle to the blast hose close to the nozzle holder, as shown in Figure 4, using the two nylon ties provided. After the control is firmly attached, clip the tie ends to avoid snags or interference with the operation of the control handle.

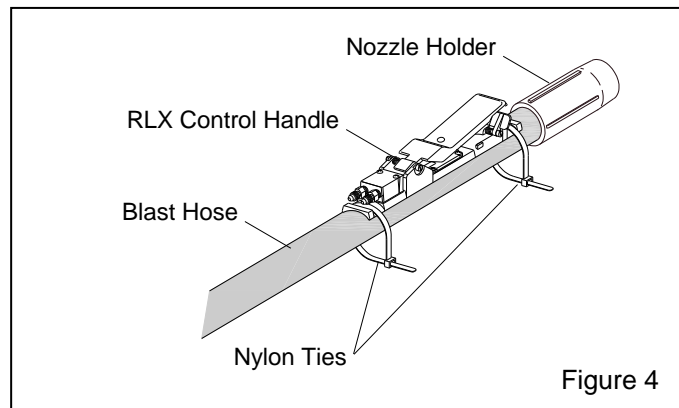

Figure 4

**2.4.3** Attach the 50-foot twinline hose to the two fittings on the control handle; either side of the hose can be attached to either fitting. When using the ACS option, attach the single line hose noted in Section 2.5.

NOTE: When attaching Clemco twinline hose to any Clemco valves; either side of the hose can be attached to either twinline fitting the valve.

**2.4.4** Working backward from the control handle, band or tape the twinline hose to the blast hose every four to six feet, and as close to the couplings as possible.

**2.4.5** Temporarily connect the blast hose to the quick coupling on the blast machine.

**2.4.6** Attach the 5-ft. twinline control hose to the inlet valve as shown in Figure 2; one side of the hose connects to the unused upper elbow, the other to the orifice fitting

NOTE: When using a pressure regulator to reduce blast pressure below 60 psi (80 psi when using an ACS), relocate the orifice upstream of the regulator as shown in the insert in Figure 2, and plug the orifice port in the inlet valve. This allows the pneumatic control circuit to operate at line pressure.

**2.4.7** Connect the two hose unions to the other end of the 5-ft. hose and place the ends next to the blast hose coupling.

**2.4.8** Band the 5-foot twinline control hose, on the blast machine side of the unions, to the quick coupling nipple.

**2.4.9** Attach the 50-foot twinline hose to the unions on the 5-ft. twinline.

**2.4.10** Make sure that all fittings are tight. Leaks will cause the system to malfunction.

NOTE: When removing the blast hose from the machine, disconnect the 50-foot twinline hose at the unions. When attaching the blast hose make sure all twinline fittings are tight. Make sure coupling gaskets are in place and in good condition before connecting the blast hose to the blast machine. Use safety lock-pins or safety wire to lock the couplings together and prevent accidental separation while under pressure, and safety cables to prevent hose from whipping should separation occur.

## 2.5 Set Up for Optional ACS Ref. Figure 5

**2.5.1** Attach the 18-inch long hose to the fitting on the metering valve.

**2.5.2** Attach the 50-foot long single-line hose to the ACS air switch assembly located on the RLX control handle.

**2.5.3** Use one of the three unions to attach the 50-foot hose to the 18-inch long hose.

## 3.0 OPERATION

### 3.1 Transporting and moving

## **⚠ WARNING**

Failure to observe the following warnings before transporting or moving a blast machine could result in serious injury or death.

- Always empty the blast machine before lifting or hoisting.
- Never hoist the machine by the handle or piping, or with a sling through the handle or piping.
- Always use lift equipment that is rated higher than the weight of the machine and accessories.
- When transporting a machine on a pallet, always secure the machine to a sturdy pallet.
- Always securely anchor the machine to the transport vehicle.
- Anyone using material handling equipment to move, transport, or lift the machine must be trained and experienced with the hazards associated with handling this type of machinery.

### 3.1.1 Transporting a blast machine

**3.1.1.1** Always empty the machine before transporting. Transporting a machine containing abrasive may increase the weight to an unsafe handling limit, and could cause abrasive to settle in the piping.

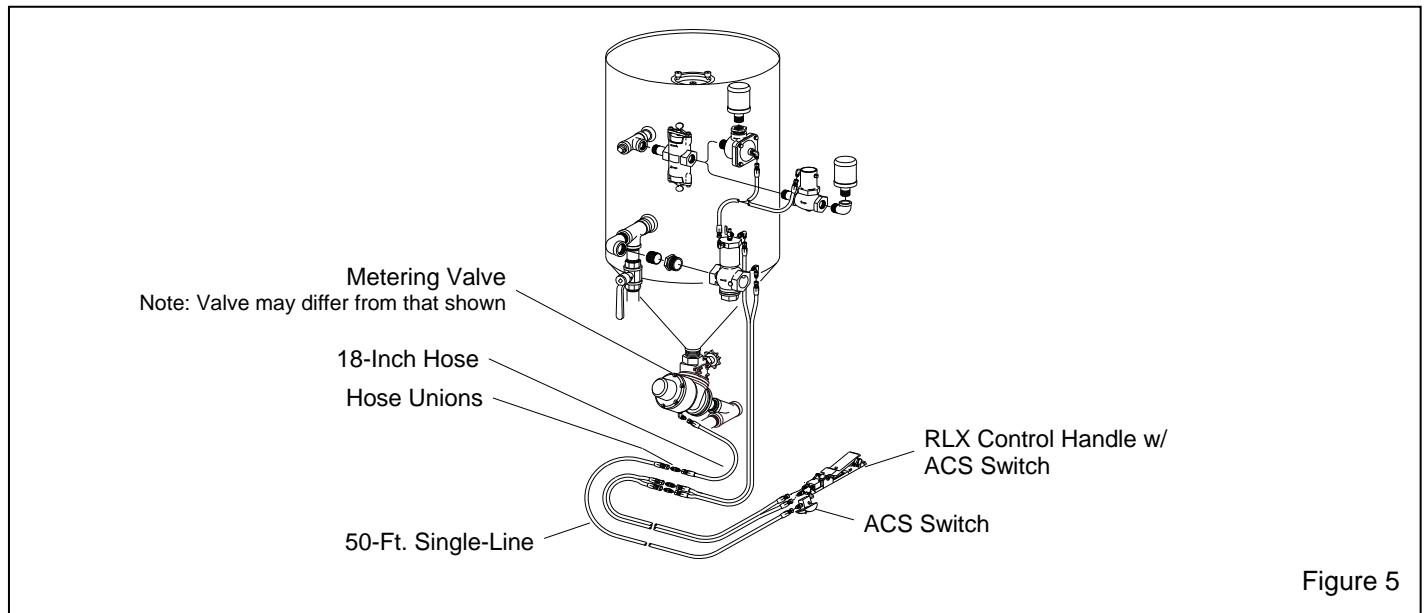

Figure 5

3.1.2 Moving a blast machine

**⚠ WARNING**

**Never attempt to manually move a blast machine when it contains abrasive. Empty machines, up to 6 cu. ft. capacity, may be moved when the following criteria are met:**

3.1.2.1 An empty machine may be moved manually, on level flat surfaces, by at least two people.

**⚠ WARNING**

**Do not manually move the machine on an incline, or on a slippery or irregular surface that could cause the operator to slip or lose balance. Sudden weight shifts when the machine is tilted on an incline and slipping or tripping while moving the machine will cause the operator to lose control of the machine, causing severe injury and property damage.**

3.1.2.2 To avoid tripping hazards that may be out of view, always move the machine by pushing it in a forward direction. Do not back-up while moving the machine,

3.1.2.3 The Clemco Mule (Stock No. 20331) is designed to assist in moving empty 1.5 cu. ft. to 6 cu. ft. capacity Clemco blast machines. Contact a Clemco Distributor for additional information.

3.2 Set-Up for Operation

3.2.1 Locate the compressor upwind from the blasting operation to prevent contaminated air from entering the compressor intake.

3.2.2 Attach an air line from the compressor to the hose fitting installed on the blast machine inlet. For best blasting performance, use the following guidelines:

Nozzle Orifice Size	Recommended Air Supply Line
No. 3, 3/16"	1" ID or larger
No. 4, 1/4"	1" ID or larger
No. 5, 5/16"	1-1/4" ID or larger
No. 6, 3/8"	1-1/2" ID or larger
No. 7, 7/16"	2" ID or larger
No. 8, 1/4"	2" ID or larger

Refer to the compressed air and abrasive consumption table in Figure 7 for approximate air consumption.

3.2.3 Make sure the coupling gaskets are in place (and in good condition) before connecting the blast hose to the quick coupling on the blast machine. Use safety lock-pins or safety wire, to lock the couplings together and prevent accidental separation during blasting.

3.2.4 Make sure that all compressed-air supply hose connections are secured with safety lock pins and safety cables to prevent accidental disconnection and hose whipping. Lock pins and safety cables are listed in Section 7.2.

**⚠ WARNING**

**Hose disconnection while under pressure could cause serious injury or death. Use safety lock-pins and safety cables on all hose coupling connections to prevent couplings from accidental disconnection.**

3.2.5 Attach the ends of the 50-foot twinline hose to the unions previously connected to the 5-foot twinline hose. Either side of the hose can be attached to either fitting.

3.2.6 Check all fittings to make sure they are wrench-tight. Leaks will cause the system to malfunction.

3.2.7 Make sure the choke valve is open (handle inline with the piping as shown in Figure 10).

3.2.8 Close the abrasive metering valve. FSV and Lo-Pot metering valves are closed when the handle is all the way to either side of center. Quantum and PVR grit valves are closed when the metering knob is turned fully clockwise.

3.2.9 Make sure that the safety petcock located on the inlet valve is open. Open position is when the lever is inline with the petcock, as shown in Figure 6.

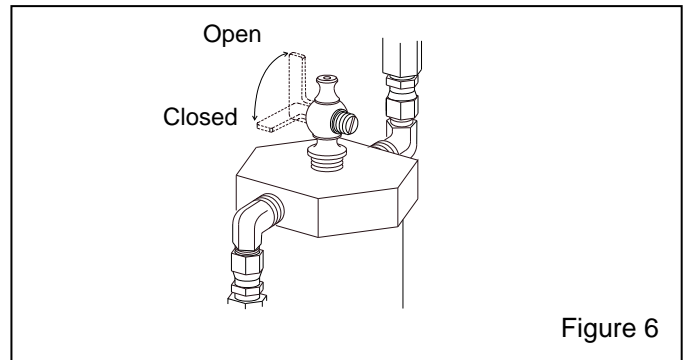

Figure 6

Compressed Air and Abrasive Consumption									
Consumption rates are based on abrasives that weigh 100 pounds per cubic foot									
Nozzle Orifice Size (in.)	Pressure at the Nozzle (psi)								Air, Power and Abrasive Requirements
	50	60	70	80	90	100	125	140	
No. 3 3/16"	26	30	33	38	41	45	55	61	Air (cfm)
	150	171	196	216	238	264	319	353	Abrasive (lbs/hr)
	6	7	8	9	10	10	12	14	Compressor (hp)
No. 4 1/4"	47	54	61	68	74	81	98	108	Air (cfm)
	268	312	354	408	448	494	608	676	Abrasive (lbs/hr)
	11	12	14	16	17	18	22	24	Compressor (hp)
No. 5 5/16"	77	89	101	113	126	137	168	186	Air (cfm)
	468	534	604	672	740	812	982	1085	Abrasive (lbs/hr)
	18	20	23	26	28	31	37	42	Compressor (hp)
No. 6 3/8"	108	126	143	161	173	196	237	263	Air (cfm)
	668	764	864	960	1052	1152	1393	1538	Abrasive (lbs/hr)
	24	28	32	36	39	44	52	59	Compressor (hp)
No. 7 7/16"	147	170	194	217	240	254	314	347	Air (cfm)
	896	1032	1176	1312	1448	1584	1931	2138	Abrasive (lbs/hr)
	33	38	44	49	54	57	69	77	Compressor (hp)
No. 8 1/2"	195	224	252	280	309	338	409	452	Air (cfm)
	1160	1336	1512	1680	1856	2024	2459	2718	Abrasive (lbs/hr)
	44	50	56	63	69	75	90	101	Compressor (hp)

- For nozzle sizes 3/8" to 1/2", blast machines should be equipped with 1-1/4" or larger piping and inlet valve to prevent pressure loss.
- Air requirements were measured by a flow meter under actual blasting conditions, and are therefore lower than figures for air alone, with no abrasive.
- Horsepower requirements are based on 4.5 cfm per horsepower.
- Figures are for reference only, and may vary for different working conditions. Several variables, including metering valve adjustments, can affect abrasive flow.
- Figures show approximate compressed air and abrasive consumption when nozzles are new. Consumption will increase as the nozzle wears.

Figure 7

**⚠ WARNING**

**To prevent severe injury from accidental activation of the blast machine, open the safety petcock when the blast machine is not in use. Opening the petcock prevents unintentional blasting. The control handle cannot activate the machine when the petcock is open.**

**3.2.10** Make sure that the remote control handle lever is in the up (no blast) position, as shown in Figure 8, and that the handle lever and safety lock move freely.

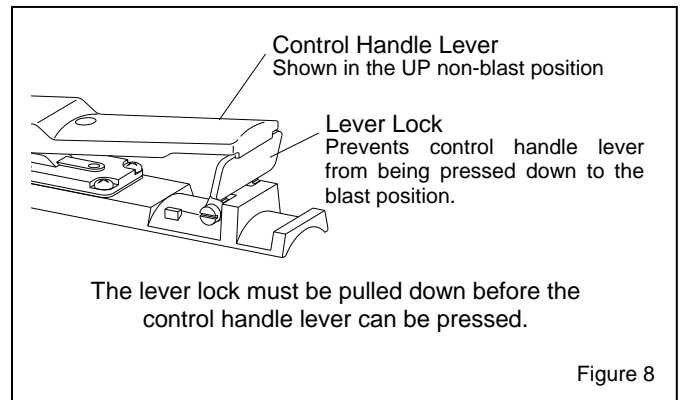

Figure 8

---

**⚠ WARNING**

---

**A separate manual is supplied with the remote control handle. Do not operate the machine before reading the remote control handle operating instructions.**

---

**3.2.11** Make sure that the handle lever will not seal the opening on the control handle, unless the safety lever lock is folded down.

---

**⚠ WARNING**

---

**Malfunctioning control handles could cause unintentional actuation of a blast machine, or prevent a machine from deactivating upon release. Malfunctioning control handles must be taken out of service immediately and repaired or replaced. Serious injury or death could result from unintentional blasting.**

---

**3.2.12** Close the air valve on the compressor. Start the compressor, and bring it to operating temperature and pressure. The pressure must be more than 50 psi, but must not exceed the blast machine's rated pressure.

**3.2.13** Slowly open the compressor air valve to pressurize the air-supply line. Listen for noise that indicates any open lines or leaks.

**3.2.14** Load abrasive into the machine by following the instructions in Section 3.9.

**3.2.15** Do not allow anyone near the blast machine except machine tenders, who are appropriately attired in approved personal protective equipment as noted in Section 3.3.

**3.2.16** When the blast operator is ready to blast, either the operator, or the machine tender, while standing back and facing away from the concave filling head of the blast machine and the exhaust muffler, closes the safety petcock. Closing the petcock prepares the machine for remote activation by the control handle. Air should be heard escaping from the orifice under the control handle lever but from nowhere else. The air escaping at the handle is an audible signal that means air is supplied to the blast machine, which activate when the control handle is pressed.

---

**3.3 Blasting Attire**

---

---

**⚠ WARNING**

---

**Before blasting, test the coating and substrate for toxic materials, such as lead or other heavy metals, or asbestos. These hazards require special measures to protect the operators and the environment.**

**No dust is safe to breathe. Abrasive blasting produces harmful dust. Failure to wear approved respirators could result in serious lung disease or death. Blast operators must wear properly-fitted and maintained NIOSH-approved, type-CE supplied-air respirators approved for abrasive blasting.**

**During abrasive blasting, abrasive particles and dust in the area around the blast machine and blast nozzle become airborne. Everyone in the vicinity of abrasive blasting must wear properly-maintained, NIOSH-approved, respiratory protection and eye protection appropriate for the job site hazards.**

**Noise generated by compressed air could cause hearing damage. Everyone in the blasting area must wear approved hearing protection.**

---

**3.3.1** Operators and **anyone else that may be exposed to the hazards generated by the blasting process** must wear appropriate protective gear, including abrasive-resistant clothing, leather gloves, eye and hearing protection, and a NIOSH-approved type-CE supplied-air respirator.

**3.3.2** Don protective blasting attire outside the blast area, in a clean non-hazardous environment, free of contaminants, where the air is safe to breathe.

**3.4 Pressurize Blast Machine to Start Blasting**

**3.4.1** Don all protective blasting attire per Section 3.3.

**3.4.2** When the blast operator is ready to blast, the operator or the machine tender must close the safety petcock. Closing the petcock prepares the machine for remote operation and activation by the control handle. Air should be heard escaping from the orifice under the control handle lever but nowhere else. The air escaping at the control handle is an audible signal meaning air is supplied to the blast machine, which will activate when the control handle is pressed.

**3.4.3** Hold the blast hose securely and point the nozzle only toward objects intended to be blasted.

**3.4.4** Fold down the safety lever lock and press the remote control handle as shown in Figure 9. Within a few seconds, the pop-up valve will automatically close, and the blast machine will pressurize to start blasting.

## **⚠ CAUTION**

**Be prepared for recoil from the blast hose. Blasting should begin within a few seconds after pressing the control handle lever.**

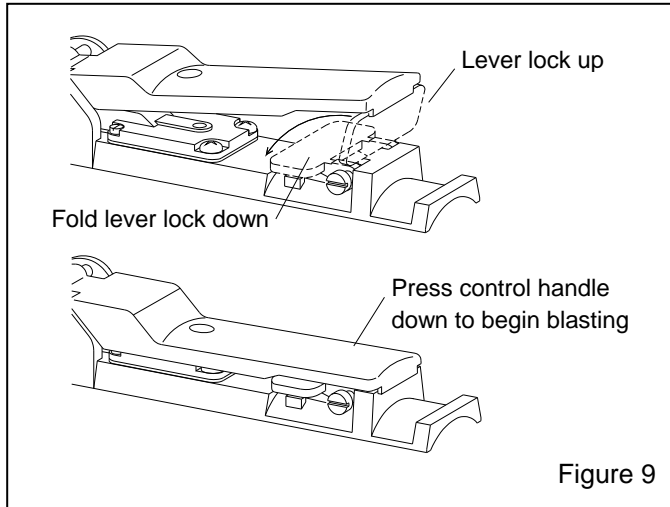

Figure 9

## **⚠ WARNING**

**OSHA requires the use of remote controls on all blast machines when an operator controls the nozzle. To comply with OSHA regulations, the remote control handle, which starts and stops the flow of air and abrasive, must be held down manually. Never tie down the control handle lever or attempt to bypass any part of the remote control system. Doing so will defeat the purpose of the fail-to-safe feature of the remote control. Serious injury or death could result from uncontrolled blasting. Ref. 29 CFR 1910.244 (b).**

**3.4.5** If the abrasive metering valve is closed as instructed, only air will exit the nozzle. Adjust abrasive flow per Section 3.5.

### **3.5 Adjust Abrasive Metering Valve**

**NOTE:** The following instructions explain the adjustment of handle-type FSV and LPV (Lo-Pot) metering valves. Knob-type valves are adjusted by turning the knob clockwise for less abrasive, or counterclockwise for more abrasive. Separate manuals are provided with optional valves.

**3.5.1** Abrasive flow is adjusted at the metering valve located at the bottom of the blast machine.

**3.5.2** Begin adjustments with the metering valve closed. Closed. The FSV and LPV metering valves are closed when the handle is turned to either side of center until it hits the stops. The optional Quantum or PVR grit valve are closed when the metering knob is turned fully clockwise.

**3.5.3** While the operator is blasting, the machine tender increases abrasive flow by moving the handle toward center, no more than 1/4" at a time, allowing time for the flow to stabilize before readjusting.

**3.5.4** Optimum abrasive flow depends on the type and size of abrasive and blasting pressure, and can best be determined by experience. Use as little abrasive as possible while maintaining the maximum cleaning rate. The air/abrasive mixture should be mainly air. As a rule, the stream of abrasive coming out of the nozzle should barely discolor the air when seen against a contrasting background.

**3.5.5** Once the correct flow is attained, loosen the wing nut on the gauge unit and move the handle bolt spacer against the metering handle. This allows the handle to be moved (opened or closed) and returned to the same setting.

### **3.6 Operation and Function of the Choke Valve Refer to Figure 10**

**3.6.1** Always fully open the choke valve while blasting; open is when the handle is vertical and inline with the piping as shown in Figure 10.

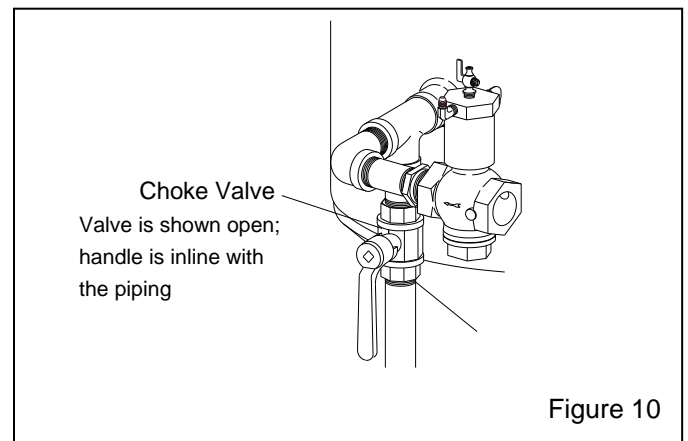

Figure 10

**3.6.2** Closing the choke valve while blasting, lowers pressure in the pusher line from the pressure in the vessel. Closing the choke valve clears the valve of minor



blockage such as damp abrasive, or is used to rapidly empty the machine at the end of the day.

**NOTICE**

**Do not blast with choke valve closed or partially closed. Prolonged blasting with the choke valve partially closed will accelerate wear on the metering valve.**

**3.7 Operation of the Optional Abrasive Cut-Off Switch (ACS), Refer to Figure 11**

**NOTE:** The ACS feature requires a pneumatically-operated abrasive metering valve. When set up at the nozzle end of the blast hose, the operator toggles the switch to remotely open and close the metering valve.

**3.7.1** The ACS serves two purposes:

1. Clearing abrasive from the blast hose when blasting is finished. This is helpful in a lot of applications and necessary when blasting vertically to prevent abrasive from collecting in low spots in the blast hose, eliminating excessive abrasive slugging at startup.
2. Blowing abrasive off the blasted surface. **NOTE:** Small amounts of residual abrasive may exit the nozzle with the air, requiring blowing off or otherwise cleaning surface outside the blasting area prior to painting.

**3.7.2** The abrasive cut-off switch is situated directly behind the control handle. The switch may be flipped open or closed at any time, but will not operate the metering valve unless the control handle is pressed.

**3.7.2.1 Blast Mode:** Moving the ACS toggle away from the nozzle to the "ON" ("CYL" port) position, sends control-air to the abrasive metering valve, opens the valve and the blast machine operates normally, with air and abrasive coming out the nozzle.

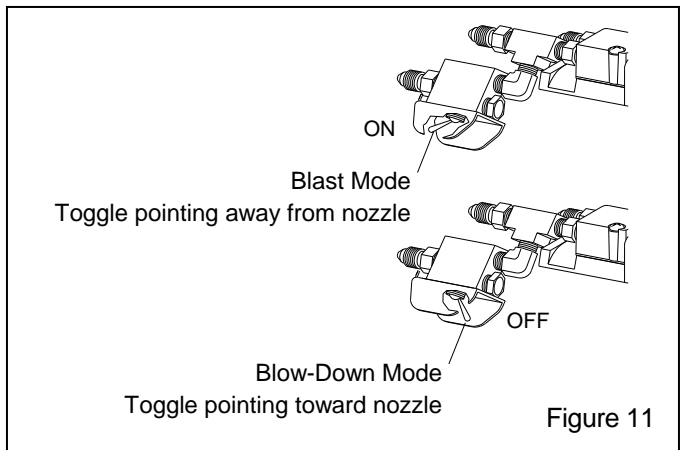

**3.7.2.2 Blow-Down Mode:** Moving the ACS toggle toward the nozzle, to the "OFF" position, cuts off the control-air to the abrasive metering valve, closes the valve and stops the abrasive flow. This action allows air alone to exit the nozzle, useful for clearing the blast hose before shutting down, and blowing abrasive and water off the blasted surface.

**WARNING**

**OSHA sets exposure limits for people and the environment. Airborne dust could increase the exposure levels beyond permissible limits. OSHA prohibits blowing with compressed air as a cleaning method for lead-based paint dust or other hazardous dust, unless the compressed air is used in conjunction with a ventilation system designed to capture the volume of airborne dust created by the compressed air, 29 CFR 1926 (h). The ACS is for blowing off abrasive from a blasted surface, NOT as a general area clean-up tool.**

**3.8 Stop Blasting**

**3.8.1** To stop blasting, release the control handle lever. The outlet valve opens, and the blast machine depressurizes. The pop-up valve automatically drops when air is expelled from the machine.

**3.8.2** When the control handle lever is released, the safety lever-lock will flip up to lock the handle lever in the up (no blast) position. Make sure the safety lever-lock is up to prevent the handle lever from engaging.

**3.8.3** Always open the safety petcock during work breaks and before filling the blast machine. Opening the petcock prevents unintentional blasting.

**3.8.4** When finished blasting, shutdown per Section 3.11.

**3.9 Loading Abrasive into the Blast Machine**

**WARNING**

**Obtain safety data sheets (SDS) for the blast abrasive. Abrasive blasting with sands containing crystalline (free) silica can lead to serious or fatal respiratory disease. As NIOSH recommends, do not use abrasives containing more than trace amounts (more than one percent) of free silica.**

**3.9.1** Load abrasive by pouring it into the concave head. Use a screen (screen comes with blast machine packages) placed over the head to prevent objects from falling inside. Foreign objects will jam the machine. Abrasive flows through the filling port into the machine. Keep the abrasive level below the pop-up valve to prevent abrasive above the pop-up valve from being forced up and out of the machine when it pressurizes.

---

## WARNING

---

**When approaching an idle blast machine, and before loading the blast machine with abrasive, always check to make sure the safety petcock is open. If it is closed, open it while standing back and facing away from the concave head and exhaust muffler. This step is especially important if one worker (a machine tender) loads the machine with abrasive while another worker (the blast operator) controls the blasting. The blast operator could pressurize the machine before the machine tender has moved away from the machine. During pressurization, abrasive could be forced out of the top of the machine, and cause injury.**

---

**3.9.2** When ready to blast, the operator or machine tender, while standing back and facing away from the concave filling head and exhaust muffler, closes the safety petcock.

**3.9.3** Begin blasting or resume blasting per Section 3.4.

### **3.10 Emptying the Machine of Abrasive**

**3.10.1** Condensation dampens abrasive and causes flow problems. When working in environments subject to extreme temperature changes, or very humid conditions, condensation may develop inside the machine. To help prevent flow problems from moist abrasive, empty the machine of all abrasive when shutting down for the day. To avoid the need to empty abrasive, load only as much abrasive as will be used during the work period. If the machine must be purged of abrasive, do the following:

**3.10.2** With the blast machine OFF, turn the blast pressure to approximately 40-50 psi, close the choke valve, and fully open the abrasive metering.

**3.10.3** To prevent wear to the nozzle holder threads, the nozzle should be firmly attached to the nozzle holder. Removing the nozzle is not recommended. If circumstances require the nozzle to be removed, also

remove the nozzle washer. Purging the machine without a nozzle in place will erode the thread area of the nozzle holder. Thread wear could cause a hazardous condition when the nozzle is reinstalled and blasting begins.

---

## WARNING

---

**The threads on the nozzle and nozzle holder must be inspected each time the nozzle is secured to the holder. A loose-fitting nozzle may eject under pressure and cause severe injury. Check the threads for wear, and make sure the nozzle holder securely holds the nozzle. The nozzle washer must also be inspected for wear. When nozzle washers are worn, abrasive could erode nozzle threads.**

---

**3.10.4** Point the nozzle into a drum or suitable storage or disposal container, or toward the direction where the abrasive is to be disposed.

**3.10.5** Hold the hose securely and pressurize the machine by activating the control handle. Be prepared for severe surging and recoil of the hose.

**3.10.6** When the machine is empty, release the control handle lever, open the safety petcock located on the inlet valve, and open the choke valve.

**3.10.7** If the nozzle was removed, thoroughly inspect the nozzle holder threads for wear before installing the nozzle washer and reattaching the nozzle.

### **3.11 Shutdown**

**3.11.1** Empty the blast machine per Section 3.10.

**3.11.2** When finished blasting, and after cleanup is completed, remove the respirator and protective clothing outside the blasting area, in a clean environment where the air is safe to breathe.

**3.11.3** Close the compressed-air supply valve at the compressor.

**3.11.4** Drain receiver tank, filters, and water collecting devices, and bleed the compressed-air supply hose.

**3.11.5** Shutdown the compressor.

**3.11.6** Cover the blast machine when not in use. Refer to Section 7.1 for optional covers.

## 4.0 PREVENTIVE MAINTENANCE

**NOTE:** The following preventive maintenance instructions pertain to the blast machine and remote controls only. Read the owners manuals for the control handle and all blast accessories, for their inspection and maintenance schedules.

### 4.1 Daily or More Frequent Inspection

**4.1.1** With the air OFF before blasting, do the following:

- Empty the abrasive trap and clean the abrasive trap screen. Do this at least twice a day, or more often if the machine is frequently cycled. Failure to clean the abrasive trap on a regular basis is a major cause of system malfunction. Refer to Section 5.6.
- Make sure couplings are secure and lock pins and safety cables are in place.
- Inspect the RLX control handle; look for the following:
  - The control handle lever must not seal the opening on the control unless the safety lever lock is folded down.
  - The **control handle lever** must return to the UP position when released.
  - The **safety lever lock** must return to the UP position when the handle lever is released.
  - Both the handle lever and safety lever lock must move freely with no drag or binding.

## WARNING

**Malfunctioning control handles could cause unintentional actuation of a blast machine, or prevent a machine from deactivating upon release. Malfunctioning control handles must be taken out of service immediately and be repaired or replaced. Serious injury or death could result from unintentional blasting.**

**4.1.2** Do the following during blasting:

- Check the control handle for leaks.
- Inspect all couplings and coupling gaskets for leaks.
- Check the blast machine vessel for leaks. If leaks are found around the pop-up valve, inspection door, pipefittings ports on the side of the machine or at the bottom of the cone, stop blasting immediately and repair or replace worn parts.

## NOTICE

**If leaks are allowed to continue, abrasive erosion could cause extensive or irreparable damage to the blast machine.**

- Check all external piping, control hoses, and valves for leaks. If leaks are found, stop blasting and repair.
- At the first sign of a leak, stop blasting and repair or replace worn parts.

## WARNING

**Leaks around couplings and nozzle holders indicate worn or loose-fitting parts. Nozzle holders and couplings that do not fit tightly on hose and nozzles that do not fit tightly in nozzle holders could disconnect while under pressure. Impact from flying objects (nozzles, couplings, hoses, or abrasive) disconnected by pressure during operation could cause severe injury.**

### 4.2 Weekly Inspection

**4.2.1** With the air OFF, before blasting, do the following:

- Inspect the blast hose for wear; squeeze the hose every three to four feet, look for soft spots. Soft spots mean the hose is worn. Replace the blast hose before the tube wears as far as the fabric plies.

## WARNING

**Worn blast hose could suddenly burst. Couplings and nozzle holders may not adequately grip worn hose, causing them to blow off under pressure. Compressed air and abrasive escaping from a burst hose, or disconnected coupling or nozzle holder, could cause severe injury.**

- Remove the nozzle for inspection. Replace with a new nozzle if the diameter is worn 1/16" or more, or if the liner is cracked.
- Make sure the nozzle washer is not worn and in place.

---



---

## WARNING

---

The threads on the nozzle and nozzle holder must be inspected each time the nozzle is secured to the holder. A loose fitting nozzle may eject under pressure and cause severe injury. Check the threads for wear, and make sure the nozzle holder securely holds the nozzle. The nozzle washer must also be inspected for wear. When nozzle washers are worn, abrasive could erode nozzle threads.

---

- When an air filter is used, inspect the filter element, and clean the bowl.

#### 4.2.2 During blasting, do the following:

- Inspect all control hoses and valves for leaks. If leaks are found, stop blasting and repair.

#### 4.2.3 After blasting inspect the following:

- Note the time it takes to fully depressurize the machine after the control handle is released. When depressurizing time increases noticeably, inspect the exhaust muffler per Section 5.10.

### 4.3 Monthly Inspection

4.3.1 With the air OFF, before blasting, do the following:

- Check the pop-up valve's urethane coating for cracks and grooves. Replace the pop-up valve at the first sign of wear, per Section 5.8.
- Inspect the rubber pop-up seal, and replace at the first sign of wear, drying, or cracking, per Section 5.9.

### 4.4 Periodic Inspection

4.4.1 The remote control system is a safety device. For safe operation and to avoid unscheduled down-time, periodically inspect the internal parts of the inlet valve, outlet valve, and abrasive trap. Inspect for wear and lubricate o-rings, pistons, springs, seals, and castings. Refer to Service Maintenance in Sections 5.3, 5.4 or 5.5, and 5.6.

4.4.2 The control handle is the actuator of the remote control system. Periodically clean around the springs, handle lever, and safety lever lock to ensure that the unit is free of abrasive and debris that may cause the handle lever or safety lever lock to bind. Refer to the RLX owner's manual for service instructions.

### 4.5 Lubrication

4.5.1 Once per week while the air is OFF, put one or two drops of light weight machine oil in the inlet valve through the safety petcock. This will lubricate the piston and o-rings in the inlet and outlet valves.

---

## 5.0 SERVICE MAINTENANCE

---

## WARNING

---

To avoid serious injury from the sudden release of compressed air, observe the following before performing any maintenance.

- Depressurize the blast machine.
  - Turn OFF the compressed air supply.
  - Lockout and tagout the compressed air supply.
  - Bleed the air-supply line to the blast machine.
- 

### 5.1 Removing Damp Abrasive from the Blast Machine

5.1.1 To clear a minor blockage caused by damp abrasive, during operation, rapidly open and close the choke valve several times.

5.1.2 For more difficult blockages, proceed as follows: Refer to Section 5.2 to check for obstructions in the metering valve.

5.1.3 With the blast machine depressurized, disconnect the blast hose and remove the gasket from the quick coupling on the machine.

5.1.4 Place the machine so that the outlet is pointed away from any objects or persons.

---

## WARNING

---

Place the machine so the outlet is pointed away from any objects or persons. Stand clear of the path of exiting abrasive. It may come out at high velocity. Impact from exiting abrasive could cause severe injury.

---

5.1.5 Close the choke valve and fully open the abrasive metering valve. Pressurize the machine to force out any damp abrasive.

5.1.6 When the obstruction has been removed, depressurize the machine. Remove the nozzle and nozzle washer, and reattach the hose. Open the choke valve and close the abrasive metering valve. Pressurize the machine to clear the hose. When the hose is cleared, depressurize the machine so the nozzle and nozzle washer can be reattached.

**⚠ WARNING**

**The threads on the nozzle and nozzle holder must be inspected each time the nozzle is secured to the holder. A loose-fitting nozzle may eject under pressure and cause severe injury. Check the threads for wear, and make sure the nozzle holder securely holds the nozzle. The nozzle washer must also be inspected for wear. Worn nozzle washers could cause thread erosion. A loose fitting nozzle may eject under pressure and could cause severe injury.**

5.1.7 With the hose cleared, start the machine using normal procedures.

**5.2 Clearing Obstructions in the Abrasive Metering Valve and Blast Machine**

5.2.1 If the nature of the obstruction permits emptying the machine of abrasive, follow the instructions, per Section 3.10.

5.2.2 Turn OFF the compressed air supply. Lockout and tagout the air supply, and bleed the air-supply line to the blast machine.

5.2.3 Remove the metering valve inspection plate by removing the wing nuts securing it.

5.2.4 Check the metering valve for blockage, by inserting a finger into the opening, and feeling for an obstruction or foreign object.

5.2.5 If the metering valve is clear, remove the blast machine inspection door, and check inside for foreign objects.

5.2.6 Make sure the inspection door gasket is in good condition, and in place before re-bolting the door onto the machine.

5.2.7 Make sure the abrasive metering valve inspection plate o-ring is in good condition and in place before reassembling the inspection plate.

5.2.8 Check to make sure all inspection doors are secure before starting the compressed-air supply.

**5.3 Inlet Valve**

All service on the inlet valve must be done with the air OFF and the air supply locked-out and tagged-out. It is not necessary to remove the valve from the blast machine.

**5.3.1 Bottom Section, Refer to Figure 12**

5.3.1.1 Use a pipe wrench to loosen the bottom cap until it can be removed by hand.

5.3.1.2 Use care when removing the cap as the spring(s) (two are used in the 1-1/2" inlet valve) and plug assembly could drop from the opening. Do not allow them to fall to the ground as damage to the castings could occur.

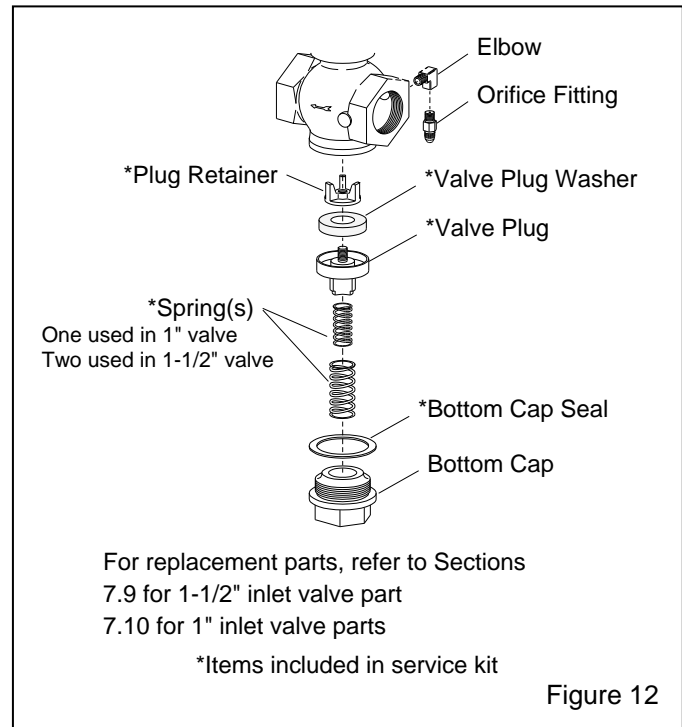

Figure 12

**5.3.1.3 Clean all parts and inspect for wear as follows:**

- The small spring (only one used in 1" valve) is approximately 1-11/16" long. If it is rusty or compressed, replace it.
- The large spring (not used in 1" valve) is approximately 2-1/16" long. If it is rusty or compressed, replace it.

- Inspect the valve plug washer, valve plug, and plug retainer for damage. Replace all damaged parts. When reassembling the valve plug assembly, tighten the retainer enough to compress the washer, but not so tight that it causes it bulge.
- Look into the lower opening in the valve body. If the machined seat is worn, replace the body.
- Inspect the bottom cap seal, and replace if damaged.

**5.3.1.4** Remove the lower twinline hose connection, and remove the orifice fitting for inspection. Clean the 1/16" orifice and reassemble the connection.

## **⚠ WARNING**

**For proper operation, the orifice fitting must always be in place. Do not modify it, or substitute another fitting. Altering the orifice fitting may cause involuntary activation of the blast machine or some other malfunction, which could result in serious injury or death.**

**5.3.1.5** If the top section of the valve requires service, proceed to Section 5.3.2, otherwise refer to the illustration in Figure 12 to reassemble the valve in reverse order.

### **5.3.2 Top Section, Refer to Figure 13**

**5.3.2.1** Remove the control hose and fittings from the cylinder cap to make sure they are not damaged by a wrench.

**5.3.2.2** Use a pipe wrench to remove the cylinder cap.

**5.3.2.3** If the bottom cap has not been removed, remove the cap and all parts in the bottom section per Section 5.3.1.

**5.3.2.4** Insert a wooden hammer handle or similar object into the bottom of the valve body, push through the seat area and drive the piston rod up. Doing so will push the piston out the top of the valve body.

**5.3.2.5** Inspect all items for wear and damage.

- The piston cup should fit snugly against the cylinder wall. If it does not, replace the piston assembly.
- The piston rod should be free of deep abrasion and move freely in the rod's bore. If it is badly abraded, drags in the bore, or is loose in the bore, replace the piston assembly.
- If the piston rod o-ring is flattened, replace the o-ring.
- Inspect the cylinder cap o-ring. Replace it if it is cut or if it does not fit snugly into the recess at the end of the threads.

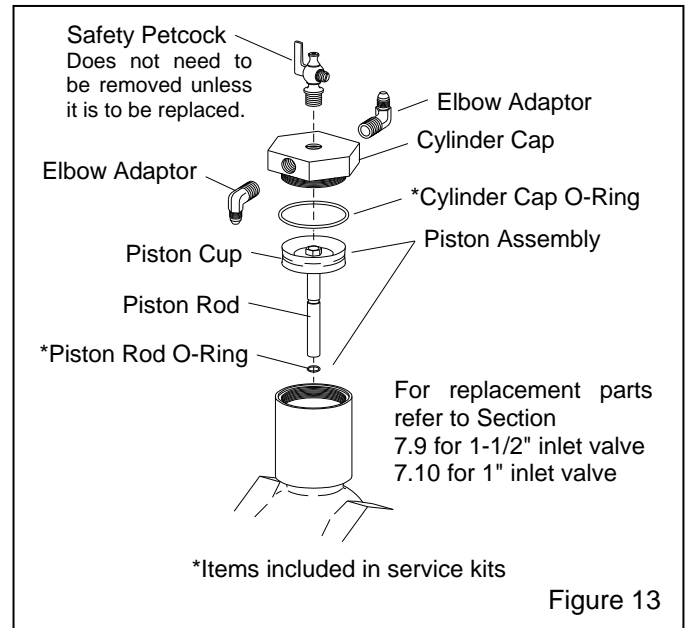

**5.3.2.6** Lubricate the cylinder wall and piston cup, with lightweight machine oil or tool oil.

**5.3.2.7** Install the piston into the cylinder. As the piston cup contacts the cylinder, it may be difficult to press into place. Do not pound the piston, as that could damage the cup; make sure the lower lip of the cup does not curl in or get cut. Rotating the piston while applying thumb pressure makes assembly easier.

**5.3.2.8** Refer to the illustration in Figure 12 and 13 to reassemble the valve in reverse order.

### **5.4 Piston Outlet Valve, Refer to Figure 14**

Refer to Section 5.5 to service the diaphragm outlet valve.

**5.4.1** All service on the outlet valve must be done with the air OFF and the air supply locked-out and tagged-out. It is not necessary to remove the valve from the blast machine.

**5.4.2** Remove the control hose from the valve bonnet's elbow adaptor. Note: The elbow adaptor and plug do not need to be removed unless they need to be replaced.

**5.4.3** Using a large wrench, loosen the bonnet from the valve body until it can be removed by hand.

**5.4.4** To remove the bonnet, lift it straight up until the piston rod clears the spindle guide.

**5.4.5** Remove the spindle, plug assembly, and spring from the valve body.

**5.4.6** Remove the piston from the bonnet by pulling the piston rod.

**5.4.7** Inspect all parts for wear and damage as follows:

- Inspect the valve plug washer, valve plug, and plug retainer for damage. Replace all damaged parts. When reassembling the valve plug assembly, tighten the retainer enough to compress the washer, but not so tight that it causes it to bulge.
- Examine the body casting for wear. If the body or the machined seat is worn, replace the body.
- Examine the spring guide-bolt and nylon washer. If either is worn, replace both.
- The spring is approximately 1-5/8" long; if it is abrasive worn, rusty, or compressed, replace it.
- The piston cup should fit snugly against the bonnet's cylinder wall. If it does not, replace the piston assembly.
- The piston rod should be free of deep abrasion and move freely in the spindle guide's bore. If it is badly abraded, drags in the bore, or is loose in the bore, replace the piston assembly.

**5.4.8** Lubricate the cylinder wall and piston cup with lightweight machine oil or tool oil.

**5.4.9** Install the piston into the bonnet's cylinder. Cocking the piston so it enters the bonnet at a slight angle, and rotating it while applying pressure makes assembly easier. Do not push the piston fully into the bonnet; the rod should be flush with the opening.

**5.4.10** Place the spring over the guide-bolt, and place the plug assembly (retainer down) on the spring.

**5.4.11** Place the spindle in the body. The large opening faces down, and fits over the plug fins. The spindle shoulder will not rest on the valve body due to the force of the spring.

**5.4.12** To assemble the bonnet to the valve body, first insert the piston rod into the spindle guide hole. While keeping the bonnet, spindle, and body aligned, screw the bonnet onto the body. If all parts are correctly aligned, the body will screw on hand-tight until it is seated. **NOTE: If the bonnet does not screw on hand tight, do not force it. Recheck alignment and repeat assembly.**

**5.4.13** After the bonnet is fully seated on the body, tighten the assembly with a wrench.

**5.4.14** Attach the control hose to the fitting on the bonnet.

**5.5 Diaphragm Outlet Valve, Refer to Figure 15**

Refer to Section 5.4 to service the piston outlet valve.

**5.5.1** All service on the outlet valve must be done with the air OFF and the air supply locked-out and tagged-out. It is not necessary to remove the valve from the blast machine.

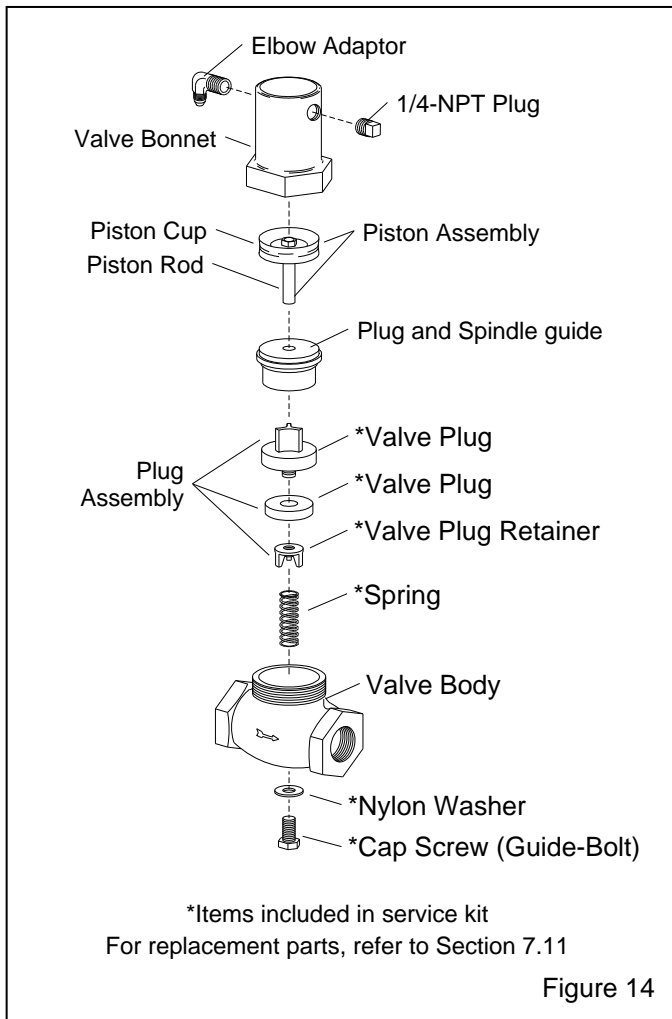

Figure 14

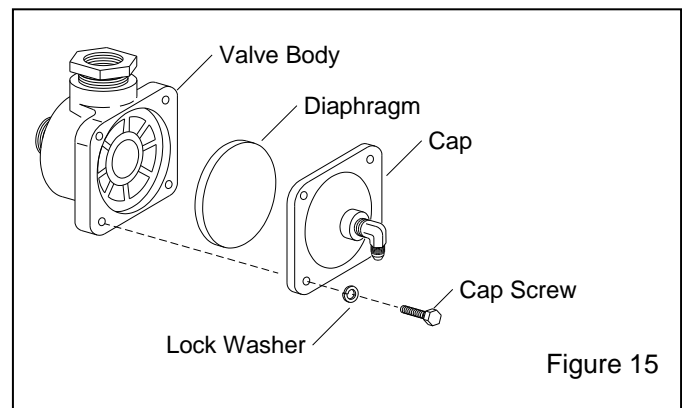

Figure 15

**5.5.2** Remove the cap by unscrewing the four cap screws.

**5.5.3** Remove the diaphragm and inspect it for damage. Replace as necessary.

**5.5.4** Inspect the seat in the body. If worn, replace the body.

**5.5.5** Reassemble in reverse order.

**5.6 Abrasive Trap, Refer to Figure 16**

**5.6.1** All service on the abrasive trap must be done with the air OFF and the air supply locked-out and tagged-out.

**5.6.2** Clean abrasive trap screen and empty the trap twice daily.

NOTE: Failure to clean the abrasive trap on a regular basis is a major cause of system malfunction.

**5.6.3** To check the abrasive trap screen, loosen the thumb screw on the upper lock bar, swing the lock bar off the cap, and remove the cap.

**5.6.4** Remove the screen and inspect it for wear and blockage. Replace it when it is clogged or worn. Keep spare screens on hand. Do not install the screen in the trap until the bottom section of the trap is cleaned per the following instructions.

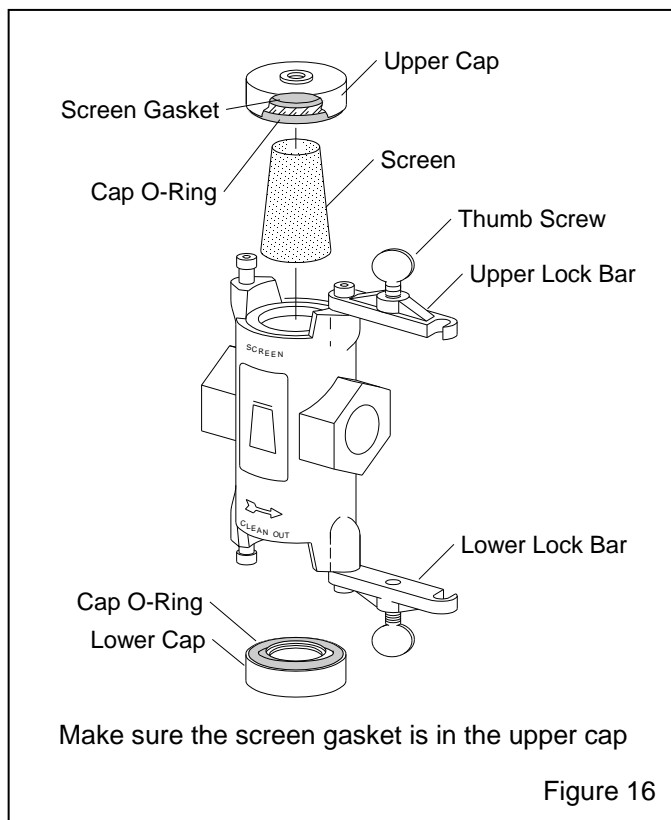

**5.6.5** To clean the bottom section of the trap, loosen the thumb screw on the lower lock bar, swing the lock bar off the lower cap, and then remove the cap.

**5.6.6** Empty all abrasive from the bottom and top sections.

**5.6.7** Install the screen in the top section. The smaller diameter end of the screen must face up as shown in Figure 16.

**5.6.8** Reassemble the upper and lower caps.  
NOTE: The upper and lower caps are identical except the screen gasket is glued into the upper cap. Make sure the screen gasket is in place in the upper cap, and the o-rings are in place on both caps before assembly.

**5.7 Control Handle**

**5.7.1** A separate manual is provided for the RLX control handle. Refer to Manual No. 10574.

**5.8. Replacing the Pop-Up Valve, Figure 17**

**5.8.1** All service on the pop-up valve must be done with the compressed air off and the air supply locked-out and tagged-out.

**5.8.2** To gain access to the pop-up valve, remove the inspection door assembly.

**5.8.3** Using a small pipe wrench, unscrew the pop-up valve guide by turning it counterclockwise. Remove the pop-up valve and guide from the machine.

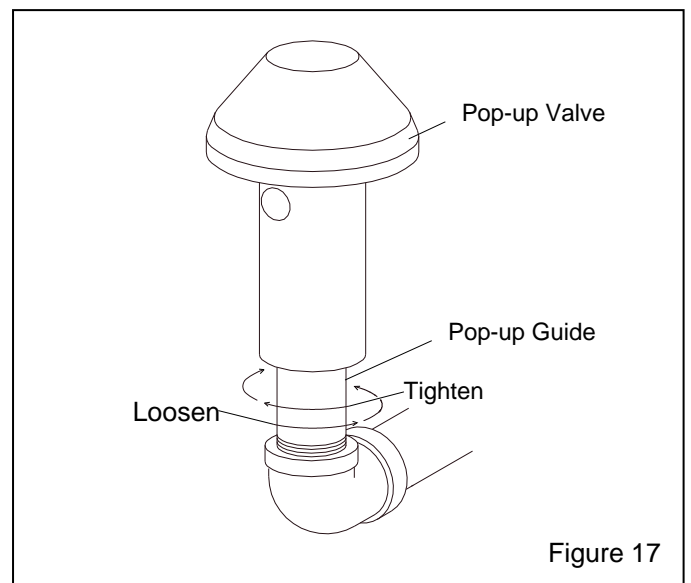



**5.8.4** While the pop-up valve is out, check alignment as follows: Screw a 1-1/4" nipple that is at least 12" long, into the elbow in place of the pop-up guide. Check the alignment through the pop-up filling port. The nipple should be close to the center of the port. If it is not, adjust the horizontal pipe. A misaligned pop-up valve could result in early valve failure, or abrasive leakage when the machine is pressurized or depressurized.

**5.8.5** Slide the new pop-up valve over the guide, and then screw the valve guide (with the pop-up valve on it) into position inside the machine. Tighten the guide wrench-slug, but not wrench-tight. Over-tightening the guide will make it difficult to remove the next time the pop-up valve needs replacement.

**5.8.6** Refer to Figure 18 to check the pop-up height. If the pop-up sits too low, misalignment could occur when the pop-up comes up against the seal. If the pop-up sits too high, it will take longer for abrasive to flow through the opening when filling. Adjust the height by replacing the guide with one that is longer or shorter.

**5.8.7** Put a new gasket on the inspection door assembly before bolting the door onto the machine.

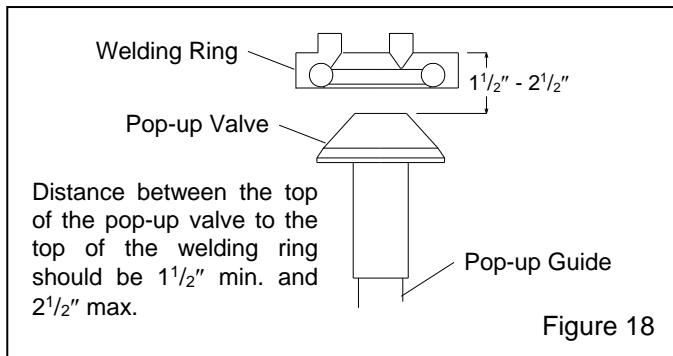

Figure 18

**5.9 Replacing the Pop-Up Seal**

**5.9.1** All service on the blast machine must be done with the compressed air off and the air supply locked-out and tagged-out.

**5.9.2** Remove the old seal using fingers, screwdriver, or similar object, to work the seal out of the retaining groove.

**5.9.3** Push the new seal all the way through the port and then fit it into the retaining groove. For the last few inches, pull up on the seal and allow it to pop into position.

**5.10 Exhaust Muffler, Figure 19**

**⚠ WARNING**

**Service the muffler, and replace the element body as soon as blast machine depressurization time increases noticeably. Longer depressurization time indicates the porous element body is becoming clogged. If the element becomes plugged, excessive air pressure could build up inside the element, and cause it to burst, which could result in injury.**

**5.10.1** All service on the muffler must be done with the compressed air off and the air supply locked-out and tagged-out.

**5.10.2** Using a pipe wrench, unscrew the 1" pipe guide, to remove the muffler assembly from the exhaust elbow.

**5.10.3** Remove the three locknuts and screws, and separate all parts.

**5.10.4** Inspect for wear. Replace parts that show signs of wear. Replace the cap if the urethane coating is worn. Always replace the element body.

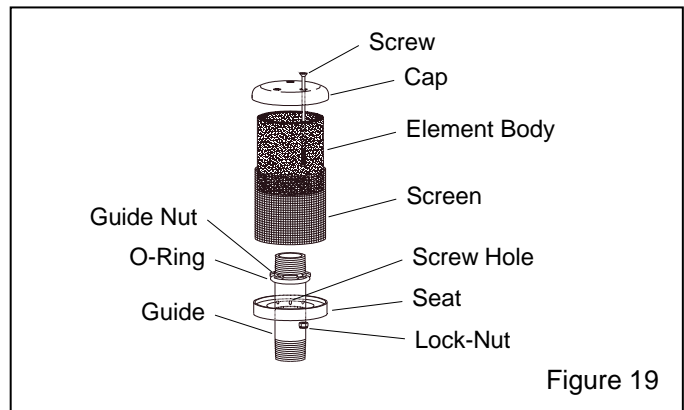

Figure 19

**5.10.5** Make sure the guide nut is fastened tightly to the guide.

**⚠ WARNING**

**Replace the guide and guide nut if the nut is not tightly fused to the guide. A loose-fitting nut could work off the guide, permitting the muffler assembly to launch under pressure, and cause severe injury.**

**5.10.6** Clean parts to be reused, with a non-caustic solvent or detergent, and dry thoroughly.

**5.10.7** Reassemble, taking care to correctly insert the screws in the seat plate. The screw holes are the three closest to the center. See the illustration in Figure 19.

**5.10.8** Firmly tighten the lock nuts.

**5.10.9** Use a pipe wrench to attach the muffler assembly to the exhaust elbow. In its final position, the muffler must face up.

## **⚠ WARNING**

**The muffler reduces exhaust noise, and prevents abrasive from exhausting upward or sideways when the blast machine is depressurized. To reduce risk of injury from abrasive carried by high velocity air, the muffler must be installed with the body facing up.**

### **5.11 Remove and Install Reusable Control Hose Ends**

NOTE: Control hoses may be shortened and cut to length as follows, ref. Figure 20:

1. Remove the hose end by placing the sleeve in a vise or use a backup wrench on the sleeve to prevent it from turning. Unscrew the insert by turning it counterclockwise.
2. Turn sleeve clockwise to remove from the hose.
3. Cut hose to length.
4. Turn sleeve counterclockwise to install on hose. Do not over-tighten the sleeve, stop tightening as soon as the hose bottoms-out against the sleeve's internal shoulder. Over tightening will cause the hose to curl inward and could cause blockage.
5. Push end of insert into sleeve, and turn clockwise to tighten until the insert hex is against the sleeve.

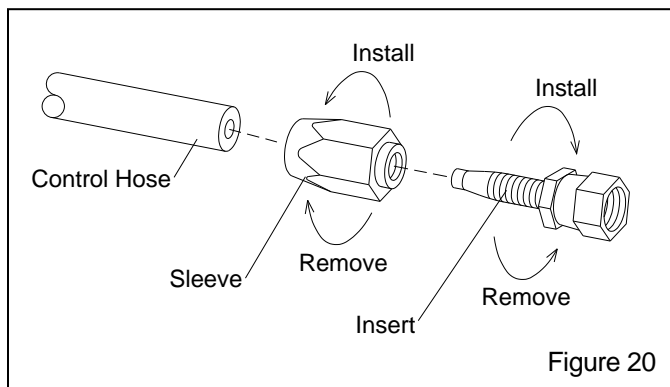

Figure 20

## **6.0 TROUBLESHOOTING**

**NOTE:** This section only identifies conditions and problems in the blast machine and remote control system. Always refer to the appropriate section of this manual, or manuals for accessory equipment when troubleshooting and before servicing the equipment. A separate manual is provided for the RLX control handle.

## **⚠ WARNING**

**To avoid serious injury, observe the following when troubleshooting the machine and remote controls.**

- Turn OFF the compressed air, and lockout and tagout the air supply.
- When checking the controls requires air, always enlist the aid of another person to operate the control handle while holding the nozzle securely and pointing it in a safe direction.
- Never strap the remote control handle lever down in the operating position.

### **6.1 Neither abrasive nor air comes out of the nozzle while the machine is under pressure**

**6.1.1** Depressurize the blast machine. After the pop-up valve has dropped, remove the nozzle, and check it for obstruction.

**6.1.2** Make sure both the abrasive metering valve and choke valve are open.

### **6.2 Air only (no abrasive) comes out of the nozzle**

**6.2.1** Abrasive metering valve may be closed or needs adjustment. Adjust abrasive flow per Section 3.5.

**6.2.2** Blast machine may be empty.

**6.2.3** Abrasive may be damp. Refer to Section 5.1 to clear damp abrasive.

**6.2.4** Check the abrasive metering valve for obstructions, per Section 5.2.

### **6.3 Heavy abrasive flow**

**6.3.1** Make sure the choke valve is open. The valve is open when the handle is inline with the piping.

**6.3.2** Abrasive metering valve may be open too far. Refer to Section 3.5.

**6.4 Abrasive surging**

**6.4.1** A moderate amount of abrasive surge is normal at start-up. Should the flow of abrasive continue to surge, reduce the amount of abrasive in the air stream by adjusting the metering valve. Refer to Section 3.5.

**6.4.2** Check the abrasive trap and exhaust muffler for blockage. Slow depressurization will load the blast hose with abrasive, and cause surging at start-up.

**6.4.3** Blast machine may be depressurizing too slowly, forcing abrasive into the blast hose. See Section 6.6.

**6.5 Blast machine will not pressurize**

**6.5.1** Make sure the compressor is ON and all air-supply valves to the machine are open.

**6.5.2** Make sure the safety petcock on the inlet valve is closed.

**6.5.3** Check the rubber button on the control handle for wear or damage, and make sure the opening on the control handle seals when the handle is pressed. (RLX control handle is covered in Manual No. 10574)

**6.5.4** Check for air escaping through the opening under the control handle lever. If no air escapes, the orifice on the inlet valve, as shown Figure 12, is blocked, or the line from the orifice to the control handle is blocked and must be cleared.

**6.5.5** Press the control handle lever. Feel for and listen for air leaks anyplace on the handle. No air should escape when the handle lever is pressed. If there is a leak, it must be located and repaired.

**6.5.6** Check control lines and fittings for air leaks.

**6.5.7** Open the safety petcock and press the control handle lever; air should come out of the petcock. If it does not, check the following:

- Opening on the control handle is not sealed off.
- Air leaks in control handle.
- Line from the control handle to the upper fitting on the inlet valve is blocked.
- If a diaphragm outlet valve is used, check the diaphragm for a split or damage.

If air comes out the petcock, then the inlet valve is not functioning. Turn OFF the compressed-air supply and service the valve per Section 5.3.

**6.5.8** Close the safety petcock, and press the control handle lever. Verify that no air escapes through the vent hole on the cylinder body of the inlet valve body. Air

escaping from this vent indicates a worn piston or piston o-ring in the inlet valve. Refer Section 5.3.

**6.5.9** Compressor too small for nozzle, reduced air-supply hose or fittings between the compressor and blast machine. Refer to the cfm consumption table in table in Figure 7 and hose table in Paragraph 3.2.2.

**6.5.10** Dirty element in optional air filter. Inspect filter element.

**6.5.11** Pop-up valve stuck, or internal piping worn or out of alignment. Inspect internal piping.

**6.6 Blast machine will not depressurize or depressurizes too slowly**

**6.6.1** Abrasive trap screen blocked, or abrasive trap needs cleaning. Clean the trap at least twice daily.

**6.6.2** Exhaust muffler blocked. Refer to Section 5.10.

**6.6.3** Check the pneumatic adaptor gasket on the control handle for swelling, which restricts air flow through the handle. Refer to the control handle manual.

**6.6.4** Check for blockage in the control hoses

**6.6.5** Make sure the lower fitting on the inlet valve (Page 27, Figure 27, item 4 or Figure 28, item 4) has not been switched for a fitting with a full-flow orifice. The orifice on the 1/8" NPT end of the fitting must be 1/16" diameter.

**6.6.6** Make sure the inlet valve closes. If it does not seal-off incoming air, service the valve per Section 5.3.

**6.6.7** Disassemble the piston outlet valve, clean and lubricate it. Replace all worn or broken parts.

**6.7 Intermittent abrasive flow**

**6.7.1** Moisture in the blast machine or in the air supply. Drain moisture from the compressor's receiver tank, and if so equipped, the blast machine's air filter. If problem with moisture persists, an after-cooler or air dryer may be required.

**6.7.2** Abrasive may be worn from recycling. Replace abrasive.

**6.8 Outlet valve will not seal**

**6.8.1** Outlet valve requires service. For piston outlet valve, refer to Section 5.4, for diaphragm outlet valve, refer to Section 5.5.

7.0 REPLACEMENT PARTS

7.1 Blast Machine Accessories

Description	Stock No.
Cover, steel for	
14" diameter machine .....	02334
16" diameter machine .....	02335
20" diameter machine .....	20358
24" diameter machine .....	02336
30" diameter machine .....	02337
Cover, poly bag with Clemco logo for	
2 and 3 cu. ft. machines, medium .....	15097
4 and 6 cu. ft. machines, large .....	15143
Screen, recessed type, for	
14" diameter machine .....	03098
16" diameter machine .....	03099
20" diameter machine .....	20357
24" diameter machine .....	03100
30" diameter machine .....	03101
36" diameter machine .....	02391
Air filter, 1" NPT manual drain .....	22424
Air filter, 1" NPT auto drain .....	22425
Air filter, 1-1/2" NPT manual drain .....	22363
Air filter, 1-1/2" NPT auto drain .....	22364

7.2 Hose Safety Accessories, Figure 21

Item Description	Stock No.
1. Safety cable	
for 1-1/2" to 3" OD hose .....	15013
for 1-1/2" to 4" OD hose .....	27405
2. Lock pin, coupling (package of 25) .....	11203

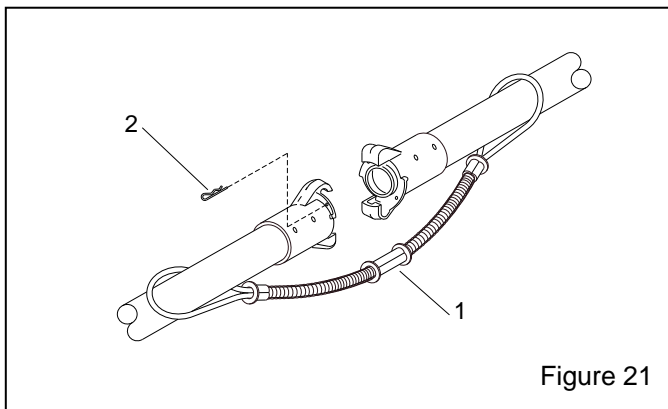

7.3 TLR-100/300 Systems, Complete

Description	Stock No.
TLR-100, 1" w/ piston outlet valve .....	01935
TLR-300, 1-1/4" w/ piston outlet valve .....	01936
TLR-100D, 1" w/ diaphragm outlet valve .....	03449
TLR-300D, 1-1/4" w/ diaphragm outlet valve .....	03448
TLR-100C, 1" w/ACS and piston outlet valve .....	21152
TLR-300C, 1-1/4" w/ACS and piston outlet valve .....	21153
TLR-100DC, 1" w/ACS and dia. outlet valve .....	21154
TLR-300DC, 1-1/4" w/ACS and dia. outlet valve .....	21155

7.4 Exhaust Muffler, Figure 22

Item Description	Stock No.
(-) Muffler, complete .....	05068
1. Screw, 8-32" x 4" .....	05061
2. Cap, coated .....	05067
3. Body, element .....	05065
4. Screen .....	05060
5. Guide w/ guide nut .....	22344
6. O-ring, 1-1/4" ID .....	05069
7. Seat .....	05062
8. Lock-nut, 8-32 ss .....	05815

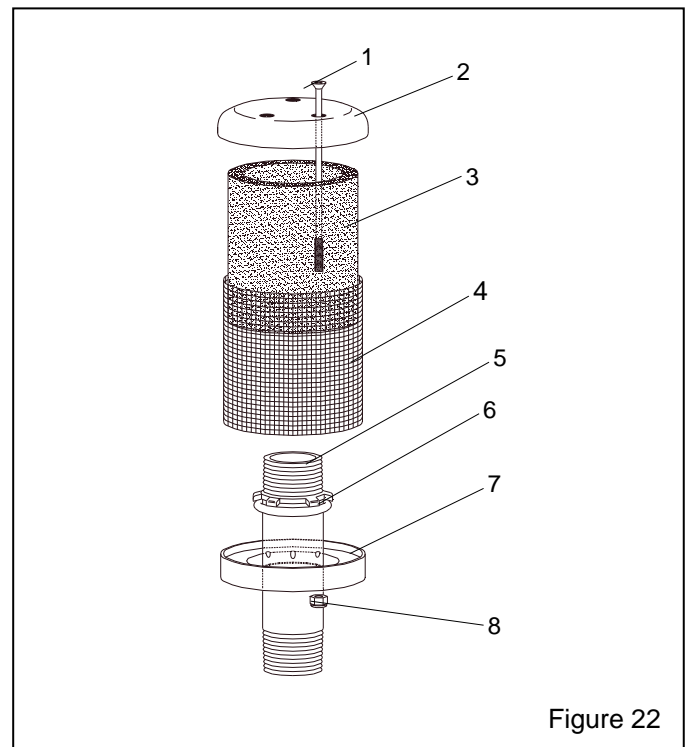

7.5 Blast Machine and Accessories, Figure 23

Item	Description	Stock No.
1.	Ball valve with handle, 1-inch NPT .....	02396
	1-1/4-inch NPT .....	02397
2.	Handle, 1" ball valve, .....	22531
	1-1/4" ball valve .....	22532
3.	Pop-up valve, 4" with external sleeve .....	03699
4.	Internal pop-up guide, toe nipple, for 2 and 3 cu. ft. 1-1/4" x 6-1/2" .....	01754
	6 cu. ft. 1-1/4" x 6" .....	01753
5.	Adaptor, male NPT x male JIC 1" NPT .....	11720
	1-1/4" NPT .....	22529
6.	Pusher line assemblies, rubber 1" ID x 21" (2 cu ft machine) .....	22508
	1" ID x 28" long (3 cu ft & 6 cu ft) .....	23673
	1-1/4" ID x 28" long (3 cu ft & 6 cu ft).....	23674
	1-1/4" ID x 31" long (7, 10 & 20 cu ft) .....	23675
	1" x 19" long (Lo-Pot machines).....	24167
	1-1/4" x 19" long (Lo-Pot machines) .....	24168
7.	Coupling, 1-1/4" CF .....	00551
8.	Wye, 1-1/4" standard .....	01818
9.	Leg pad, right, for 1.5 cu ft, 3 cu ft, and 6 cu ft machine .....	03654
	2 cu ft machine .....	20735

10.	Leg pad, left, for 1.5 cu ft, 3 cu ft, and 6 cu ft machine .....	03655
	2 cu. ft. machine .....	20736
11.	Metering valve, FSV w/ wye .....	02427
12.	Gasket, CQG coupling, (package of 10) .....	00850
13.	Wheel and tire, 10 x 2.75, for 2 cu. ft. ....	20349
14.	Axle, 2 cu. ft. 10" wheel .....	20734
15.	Wheel and tire, 16 x 400 .....	20427
16.	Axle and 16" wheel set for 3 cu. ft. machine .....	02822
	6 cu. ft. machine .....	02350
17.	Washer, 1" thrust .....	03825
18.	Retaining ring, 1" .....	03824
19.	Inspection door assembly, 6" x 8" .....	02377
20.	Gasket, 6" x 8" inspection door .....	02369
21.	Seat, pop-up gum rubber, standard use .....	02325
	neoprene, for hot climates .....	02380
22.	Umbrella, optional, 4" bolt-on .....	02318
23.	Muffler, exhaust .....	05068
24.	Metering valve, PVR manual pinch tube (optional) .....	04321
25.	Metering valve, LPV for Lo-Pot machines .....	05680
26.	Metering valve, MQV manual Quantum (optional).....	22845
27.	Lock pin, coupling (package of 25) .....	11203

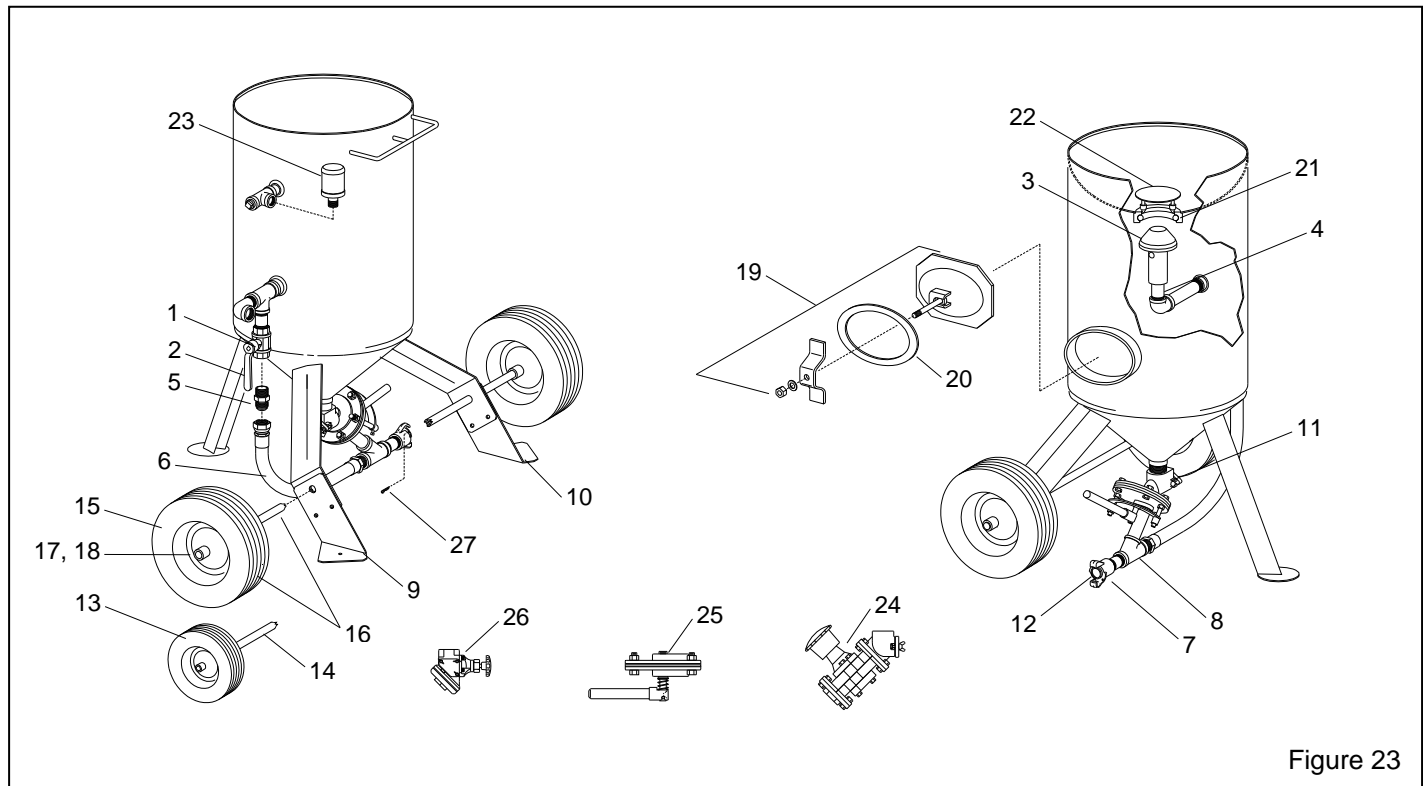

Figure 23

7.6 FSV Abrasive Metering Valve, Figure 24

Item	Description	Stock No.
(-)	Metering valve, complete .....	02427
1.	Upper body .....	02422
2.	Valve disc w/ stem .....	02423
3.	Gasket, rubber, 2 required .....	02424
4.	Disc-stainless .....	02425
5.	Lower body .....	02426
6.	Metering handle, heavy duty .....	20498
7.	Cap screw, 1/4-NC x 1-1/4" hex head .....	03054
8.	Wing nut, 1/4-NC .....	03113
9.	Handle bolt spacer .....	02431
10.	Valve handle pin .....	20246
11.	Gauge unit .....	02433

12.	Set screw, 1/4-NC x 1/2" square head .....	03080
13.	Spring, compression .....	01982
14.	Stud .....	02436
15.	Packing gland .....	02437
16.	O-ring, 7/8" OD .....	21165
17.	Gasket, shaft .....	02439
18.	Inspection plate .....	02440
19.	Cap screw 5/16-NC x 1" hex head .....	03152
20.	Wing nut, 5/16-NC .....	03213
21.	O-ring .....	01990
22.	Nipple, heavy wall 1-1/2" x close .....	01791
23.	Wye, standard 1-1/4" .....	01818
24.	Nipple, 1-1/4" x 5" .....	01721
25.	Nut, 1/2-NC hex .....	03511
26.	Cap screw, 1/2-NC x 1-3/4" hex head .....	03455
27.	Washer, 1/4" flat .....	03116
28.	Hitch pin .....	20245

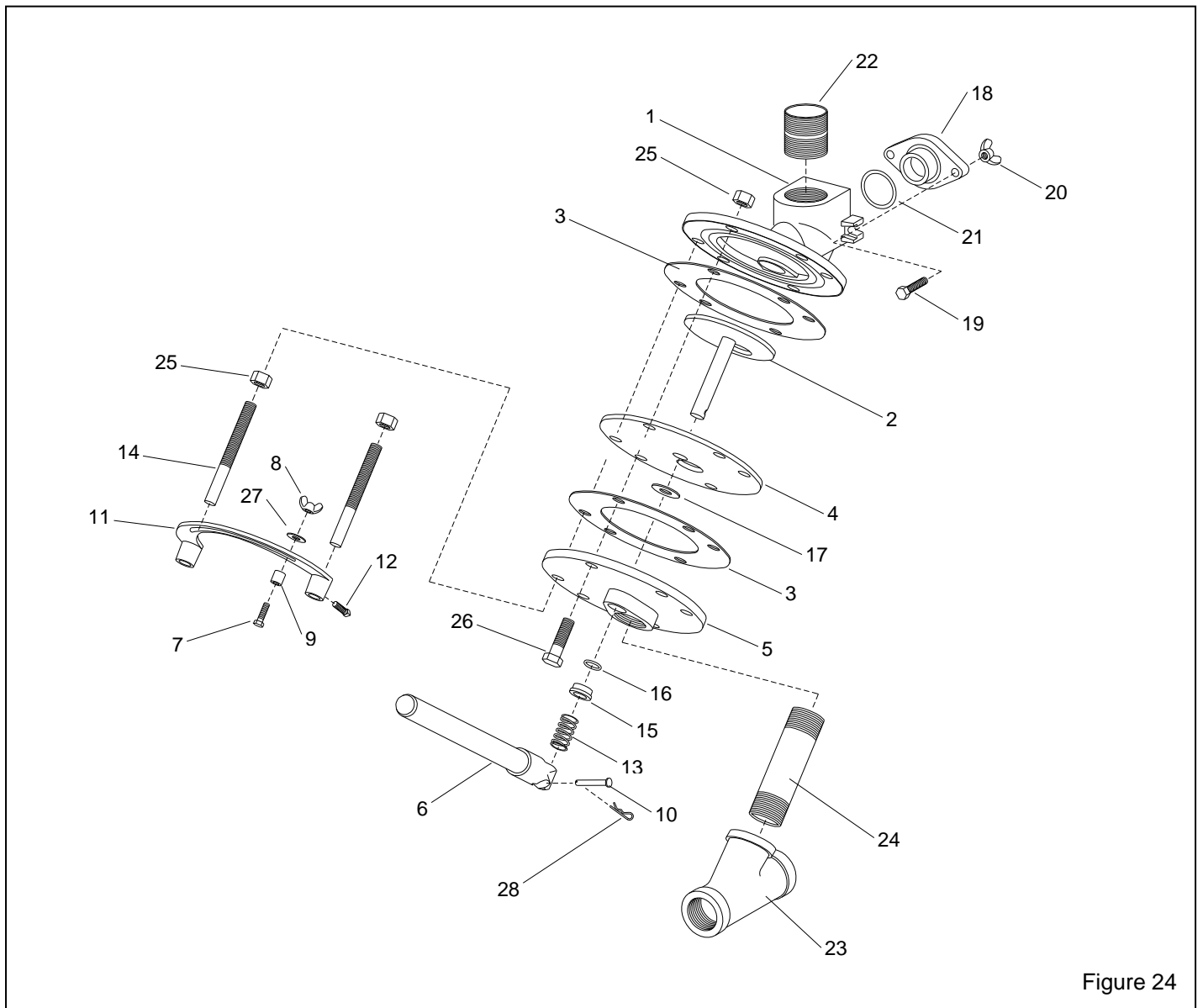

Figure 24

7.7 Remote System, Figure 25

Item	Description	Stock No.
1.	Outlet valve, 1" piston.....	01967
2.	Outlet valve, 1" diaphragm .....	03371
3.	Inlet valve 1" NPT.....	01980
	1-1/2" NPT .....	01995
4.	Abrasive trap .....	02011
5.	RLX control handle .....	10565
6.	Hose, 3/16" x 18 inch, coupled .....	02454
7.	Hose, 5 foot twinline, coupled .....	01952
8.	Hose end, reusable .....	01943
9.	Hose, 50 foot twinline, coupled .....	01951
10.	Union, hose .....	01944
11.	Elbow, 1/4" NPT adaptor .....	02513

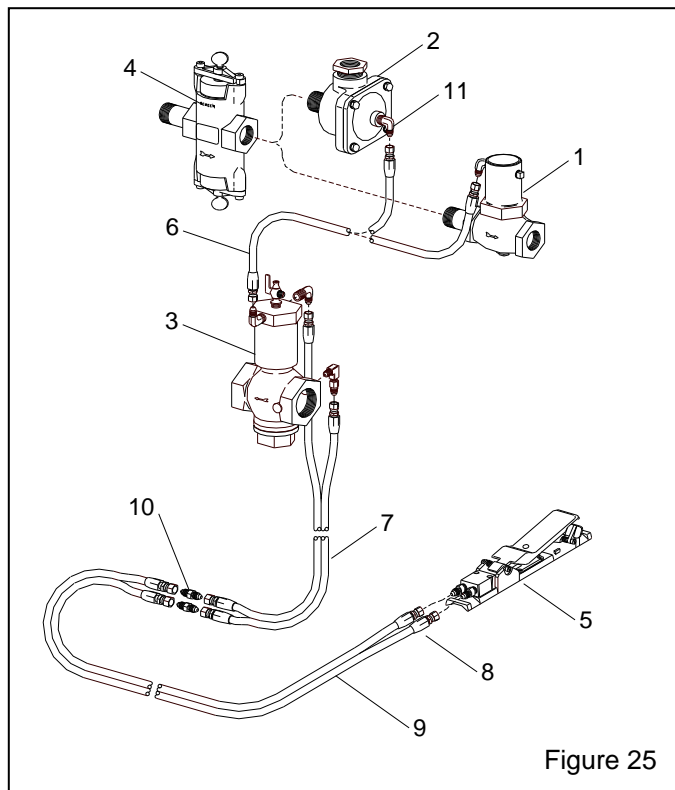

Figure 25

7.8 ACS System Replacement Parts, Figure 26

NOTE: All parts not shown are the same as those shown in Section 7.7, and Figure 5. Refer to the RLX manual for replacement parts for the ACS Control. Refer to the metering valve manual for metering valve replacement parts.

Item	Description	Stock No.
1.	RLX control handle w/ ACS switch.....	07625
2.	Hose, 50-foot single-line, coupled .....	03087
3.	Hose, 3/16" x 18", coupled .....	02454
4.	Union, twinline hose .....	01944
5.	Elbow, 1/4" NPT adaptor .....	02513

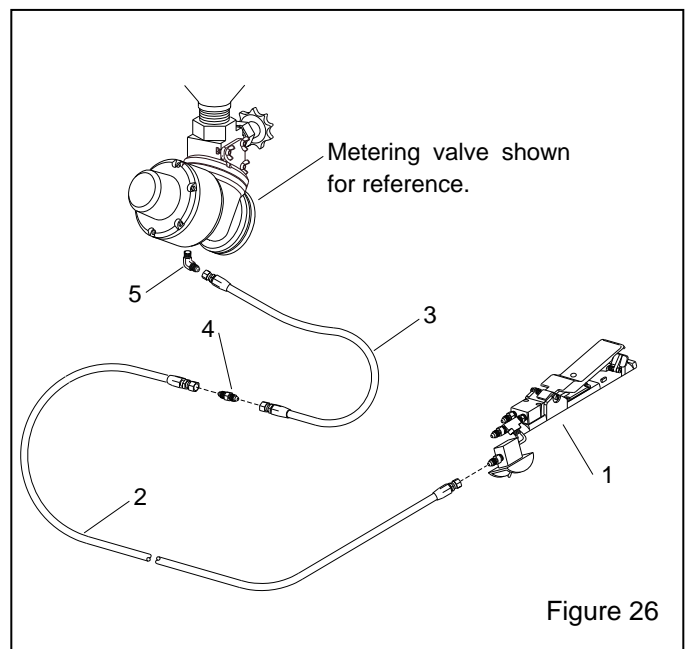
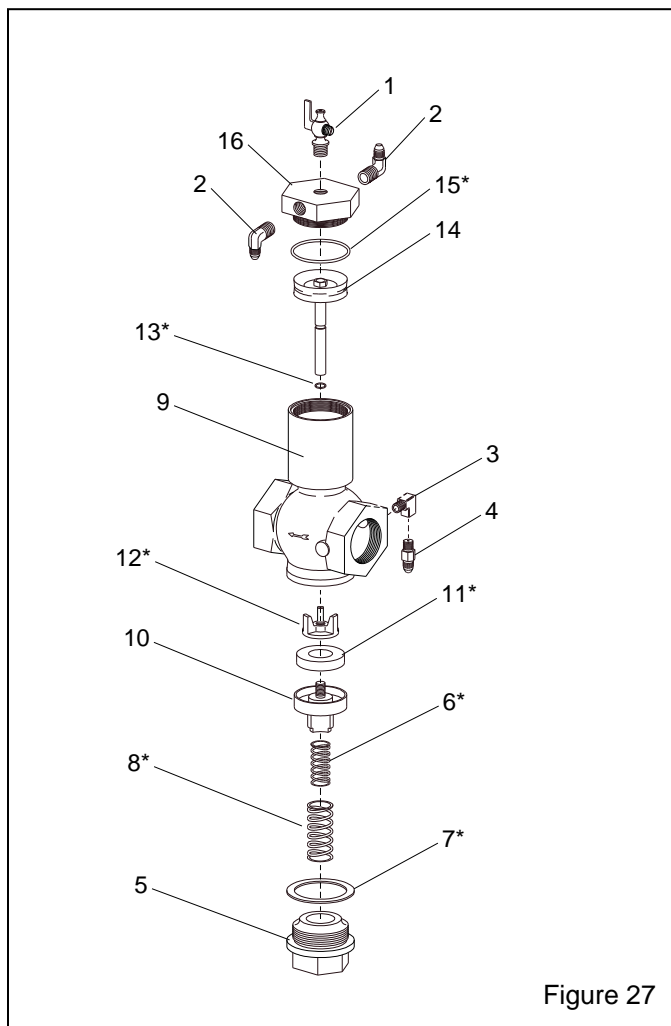

Figure 26

7.9 1-1/2" Inlet Valve, Figure 27

Item	Description	Stock No.
(-)	1-1/2" Inlet valve, complete .....	01995
1.	Petcock 1/4" NPT .....	01993
2.	Elbow, 1/4" NPT adaptor .....	02513
3.	Elbow, 1/8" NPT brass street .....	03993
4.	Adaptor 1/8" NPT with 1/16" orifice .....	01945
5.	Bottom cap .....	02001
6.*	Spring, inner, 5/8" x 1-11/16" long, (1) .....	01982
7.*	Gasket, bottom cap, (1) .....	02006
8.*	Spring, outer, (1) .....	02000
9.	Valve body .....	01996
10.	Valve plug .....	01999
11.*	Washer, valve plug, (2) .....	01998
12.*	Retainer, valve plug washer, (1) .....	02002
13.*	O-ring, 7/16" OD, (1) .....	02008
14.	Piston and rod assembly .....	02003
15.*	O-ring 2-1/4" OD, (1) .....	02007
16.	Cylinder cap .....	01997
(-)	Service kit, includes items marked * quantities are shown in ( ) .....	01927



7.10 1" Inlet Valve, Figure 28

Item	Description	Stock No.
(-)	1" Inlet valve, complete .....	01980
1.	Petcock 1/4" NPT .....	01993
2.	Elbow, 1/8" NPT adaptor .....	02827
3.	Elbow, 1/8" NPT brass street .....	03993
4.	Adaptor 1/8" NPT with 1/16" orifice .....	01945
5.	Bottom cap .....	01985
6.*	Spring, 5/8" x 1-11/16" long, (1) .....	01982
7.*	Seal, bottom cap, (1) .....	01989
8.	Valve plug .....	01984
9.	Valve body .....	01981
10.*	Washer, valve plug, (2) .....	01969
11.*	Retainer, valve plug washer, (1) .....	01986
12.*	O-ring 3/16" ID x 1/16", (1) .....	01992
13.	Piston and rod assembly .....	01987
14.*	O-ring 1-3/4" OD, (1) .....	01990
15.	Cylinder cap .....	01983
(-)	Service kit, includes items marked * quantities are shown in ( ) .....	01929

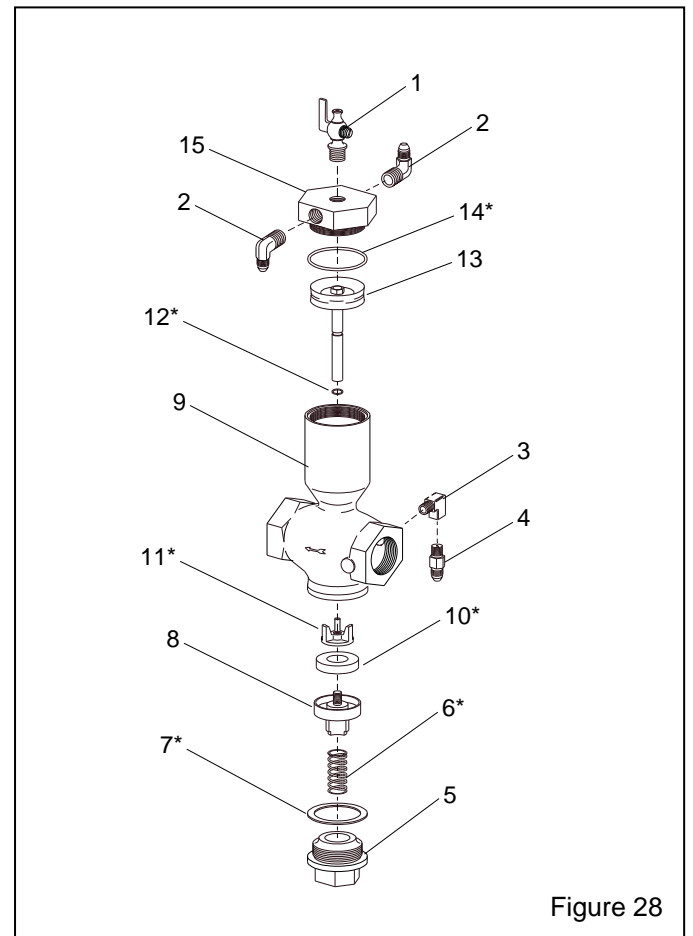



7.11 1" Piston Outlet Valve, Figure 29

Item	Description	Stock No.
(-)	1" Piston outlet valve, complete	01967
1.	Elbow, 1/4" NPT adaptor	02513
2.	Plug, 1/4" NPT	01950
3.	Bonnet	01970
4.	Piston and rod assembly	01976
5.	Plug and spindle guide	01971
6.*	Valve plug, (1)	01972
7.*	Washer, valve plug, (2)	01969
8.*	Retainer, valve plug washer, (1)	01986
9.	Valve body	01968
10.*	Spring, 7/16" x 1-5/8" long (1)	01974
11.*	Nylon washer	01979
12.*	Cap screw, 3/8-NC x 3/4"	03251
(-)	Service kit, includes items marked * quantities are shown in ( )	01928

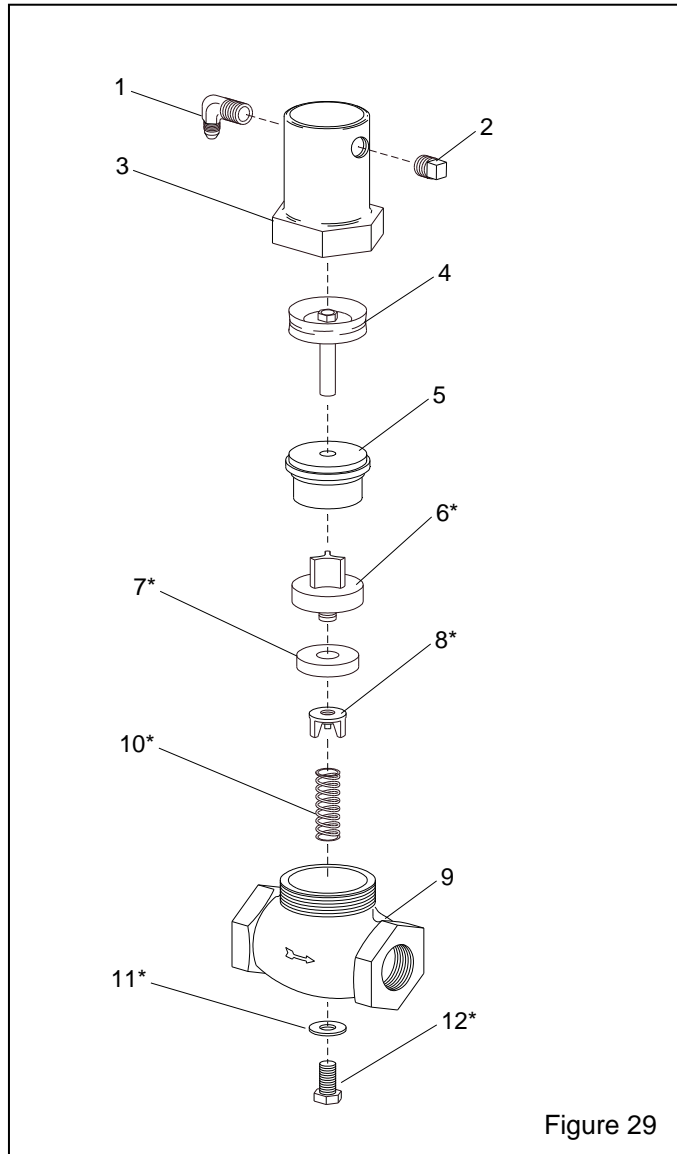

Figure 29

7.12 1" Diaphragm Outlet Valve, Figure 30

Item	Description	Stock No.
(-)	1" Diaphragm outlet valve, complete	03371
1.	Nipple, 1" x close	01701
2.	Diaphragm	06149
3.	Lockwasher, 1/4"	03117
4.	Cap screw, 1/4-NC x 1" hh	03053
5.	Cap, diaphragm outlet	03393
6.	Body, diaphragm outlet	06135
7.	Bushing, 1-1/4" x 1" NPT	01804

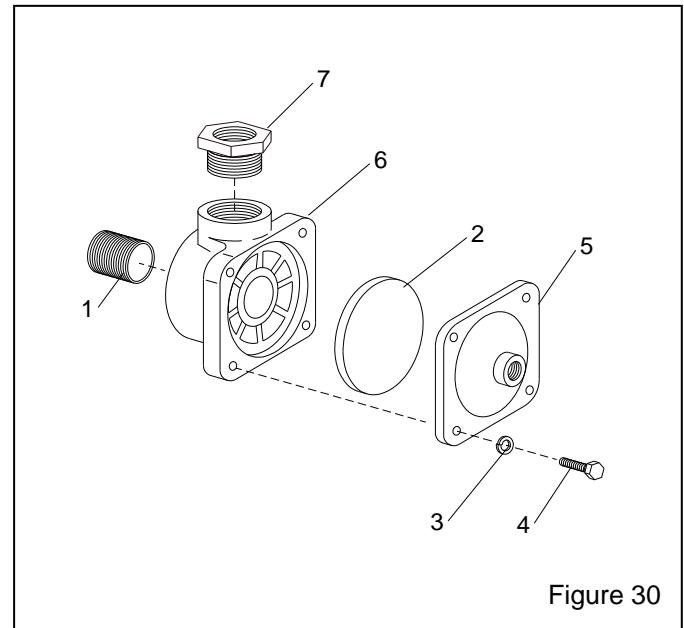

Figure 30

7.13 RLX Pneumatic Control Handle

Refer to RLX Control Handle Manual No. 10574 for RLX replacement parts.

7.14 Abrasive Trap, Figure 31

Item	Description	Stock No.
(-)	Abrasive trap, complete .....	02011
1.*	Screen, (3) .....	02012
2.*	O-ring, (2) .....	02013
3.	Cap .....	02014
4.	Body .....	02015
5.	Lock bar .....	02016
6.	Screw, 3/8-NC x 1" thumb .....	03289
7.	Shoulder screw, 3/8" x 3/8" .....	03291
8.*	Gasket, screen, 1/8" Thick, (1) .....	02434
9.*	Decal, clean screen .....	02129
(-)	Service kit, includes items marked * quantities are shown in ( ) .....	01925

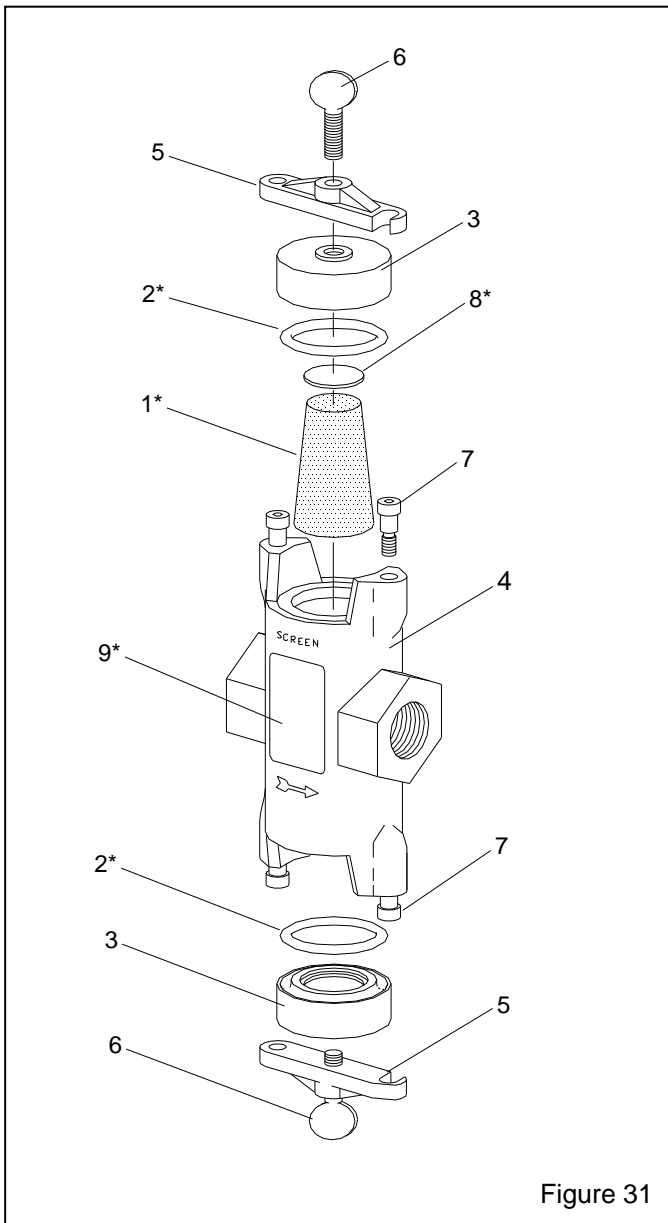

Figure 31