

**CONTRACTOR SERIES BLAST MACHINE
4 AND 6 CU. FT. WITH MILLENNIUM ACS
PNEUMATIC REMOTE CONTROLS
O. M. 22558**

**DATE OF ISSUE: 08/99
REVISION: G, 10/16**

WARNING

Do not use this equipment until you have READ this MANUAL and YOU UNDERSTAND its contents. *

These WARNINGS are included for the health and safety of the operator and those in the immediate vicinity.

***If you are using a Clemco Distributor Maintenance and Parts Guide, refer to the orange warnings insert preceding the Index before continuing with the enclosed instructions.**

Electronic files include a Preface containing important information.

© 2016 CLEMCO INDUSTRIES CORP.
One Cable Car Dr.
Washington, MO 63090
Phone (636) 239-4300
Fax (800) 726-7559
Email: info@clemcoindustries.com
www.clemcoindustries.com



WARNING

- Employers are responsible for identifying all job site hazards, educating and training all persons who will operate and maintain these products, and ensuring that all blast operators and their assistants understand the warnings and information contained in these instructions relating to safe and proper operation and maintenance of this equipment.
- Serious injury or death can result from failure to comply with all Occupational Safety and Health Administration (OSHA) regulations and all manufacturer's instructions.
- This equipment is not intended for use in any area considered hazardous per National Electric Code NFPA 70 2011, Article 500.
- Read this document and follow all instructions before using this equipment.

OSHA regulations relating to abrasive blasting are contained in the Code of Federal Regulations, Title 29 (29 CFR 1910 General Industry; 1915 Maritime; 1926 Construction). The most pertinent include: 1910.94 Ventilation, 1910.95 Occupational Noise Exposure, 1910.132 Personal Protective Equipment, 1910.133 Eye and Face Protection, 1910.134 Respiratory Protection, 1910.135 Head Protection, 1910.244 (b) Remote Controls. Consult www.osha.gov for complete information.

NOTICE TO PURCHASERS AND USERS OF OUR PRODUCTS AND THIS INFORMATIONAL MATERIAL

Clemco proudly provides products for the abrasive blast industry and is confident that industry professionals will use their knowledge and expertise for the safe and efficient use of these products.

The products described in this material, and the information relating to these products, are intended for knowledgeable, experienced users.

No representation is intended or made as to: the suitability of the products described here for any purpose or application, or to the efficiency, production rate, or useful life of these products. All estimates regarding production rates or finishes are the responsibility of the user and must be derived solely from the user's experience and expertise, not from information contained in this material.

It is possible that the products described in this material may be combined with other products by the user for purposes determined solely by the user. No representations are intended or made as to the suitability of or engineering balance of or compliance with regulations or standard practice of any such combination of products or components the user may employ.

Abrasive blast equipment is only one component of an abrasive blasting job. Other products, such as air compressors, air filters and receivers, abrasives, scaffolding, hydraulic work platforms or booms, equipment for lighting, painting, ventilating, dehumidifying, parts handling, or specialized respirators or other equipment, even if offered by Clemco, may have been manufactured or supplied by others. The information Clemco provides is intended to support the products Clemco manufactures. Users must contact each manufacturer and supplier of products used in the blast job for warnings, information, training, and instruction relating to the proper and safe use of their equipment.

GENERAL INSTRUCTIONS

This material describes some, but not all, of the major requirements for safe and productive use of blast machines, remote controls, respirator systems, and related accessories. All equipment and accessories must be installed, tested, operated and maintained only by trained, knowledgeable, experienced users.

The blast operator and all workers in the vicinity must be properly protected from all job site hazards including those hazards generated by blasting.

Work environments involving abrasive blasting present numerous hazards. Hazards relate to the blast process from many sources that include, but are not limited to, dust generated by blasting or from material present on the surface being blasted. The hazards from toxic materials may include, but are not limited to, silica, cyanide, arsenic, or other toxins in the abrasives or in the coatings, such as lead or heavy metals. Other hazards from toxins include, but are not limited to, fumes from coating application, carbon monoxide from engine exhaust, contaminated water, chemicals or asbestos. In addition, physical hazards that may be present include, but are not limited to, uneven work surfaces, poor visibility, excessive noise, and electricity. Employers must identify all job site hazards and protect workers in accordance with OSHA regulations.

Never modify Clemco equipment or components or substitute parts from other manufacturers for any Clemco components or parts. Any unauthorized modification or substitution of supplied-air respirator parts violates OSHA regulations and voids the NIOSH approval.

IMPORTANT

Contact Clemco for free booklets:

Blast Off 2 – Guide to Safe, Productive, and Efficient Abrasive Blasting, and Abrasive Blasting Safety Practices – Guide to Safe Abrasive Blasting.

Clemco Industries Corp. One Cable Car Drive Washington MO 63090

Tel: 636 239-4300 — Fax: 800 726-7559

Email: info@clemcoindustries.com

Website: www.clemcoindustries.com

OPERATIONAL INSTRUCTIONS

OPERATOR SAFETY EQUIPMENT

WARNING

- OSHA regulation 1910.134 requires appropriate respiratory protection for blast operators and workers in the vicinity of blasting. These workers must wear properly-fitted, properly-maintained, NIOSH-approved, respiratory protection that is suitable for the job site hazards. Blast respirators are to be worn only in atmospheres not immediately dangerous to life or health from which wearers can escape without use of the respirator.
- The employer must develop and implement a written respiratory protection program with required worksite- specific procedures and elements for required respirator use. The employer must provide effective training to employees who are required to use respirators. The training must be comprehensive, understandable, and recur annually, and more often if necessary.
- NEVER use abrasives containing more than one percent crystalline silica. Fatal diseases, such as silicosis, asbestosis, lead or other poisoning, can result from inhalation of toxic dusts, which include, but are not limited to, crystalline silica, asbestos, and lead paint. Refer to NIOSH Alert 92-102; and OSHA CPL 03-00-007: “National Emphasis Program – Crystalline Silica”, in which OSHA describes policies and procedures for implementing a national emphasis program to identify and reduce or eliminate health hazards from exposure to crystalline silica. Numerous topics associated with the hazards of crystalline silica in silica blasting sand can be found on [http:// osha.gov/](http://osha.gov/). Clemco urges users of silica blasting sand to visit this website, and read and heed the information it contains.
- Always make sure the breathing air supply (respirator hose) is not connected to plant lines that supply gases that include, but are not limited to, oxygen, nitrogen, acetylene, or other non-breathable gas. Never modify or change respirator air line connections without first testing the content of the line for safe breathing air. Failure to test the line may result in death to the respirator user.

- Breathing air quality must be at least Grade D, as defined by the Compressed Gas Association specification G-7.1, per OSHA Regulation 29 CFR 1910.134. When compressed air is the breathing air source, a Clemco CPF (suitable sorbent bed filter) should be used. Respirator hose connecting the respirator to the filter must be NIOSH approved. Non- approved hose can cause illness from chemicals employed to manufacture the hose.

- All workers must always wear NIOSH-approved respirators when any dust is present. Exposure to dust can occur when handling or loading abrasive, blasting, cleaning up abrasive, or working in the vicinity of blasting. Before removing the respirator, test the air with a monitoring device to ensure it is safe to breathe.

- Clemco respirators DO NOT remove or protect against carbon monoxide or any other toxic gas. Monitoring devices must be used in conjunction with the respirator to ensure safe breathing air. Always locate compressors and ambient air pumps where contaminated air will not enter the air intake.

- Always use Clemco lenses with Clemco respirators; installing non-approved lenses voids the NIOSH approval. Respirator lenses are designed to protect the wearer from rebounding abrasive; they do not protect against flying objects, heavy high-speed materials, glare, liquids, or radiation.

INDUSTRY ORGANIZATIONS

For additional information, consult:

Occupational Safety and Health Administration (OSHA) - www.osha.gov

Compressed Gas Association (CGA) - www.cganet.com

The Society for Protective Coatings (SSPC) - www.sspc.org

National Association of Corrosion Engineers (NACE) - www.nace.org

American Society for Testing and Materials (ASTM) - www.astm.org

National Institute of Occupational Safety and Health (NIOSH) - www.niosh.gov

American National Standards Institute (ANSI) - www.ansi.org

PREFACE

BLAST MACHINES AND REMOTE CONTROLS

⚠ WARNING

OSHA regulation 1910.169 describes the necessity of pressure relief valves on compressed air equipment. Do not operate blast machines with air compressors that are not equipped with properly functioning pressure relief valves.

OSHA regulation 1910.244(b) requires the use of remote controls on blast machines.

Serious injury or death can result from many sources, among them:

- Involuntary activation of the remote controls. Never modify or substitute remote control parts; parts are not compatible among different manufacturers. Welding hose is not suitable for remote control hose. Its ID and material composition make it unsafe for remote control use.
- Exceeding the maximum working pressure. Clemco blast machines are built to ASME-code and carry a 'U' or 'UM' stamp, and National Board/serial number. Every machine is marked with its maximum working pressure. Never exceed the maximum working pressure limits of the blast machine.
- Uncontrolled blast stream. High-velocity abrasive particles will inflict serious injury. Always point the blast nozzle in the direction of the blast surface only. Keep unprotected workers out of the blast area.
- Welding on the blast machine. Never weld on the blast machine; welding voids the National Board approval and may affect the dimensional integrity of the vessel.
- Moving the blast machine. Never manually move a blast machine containing abrasive, any machine containing abrasive must be moved with appropriate mechanical lifting equipment.

HOSES, COUPLINGS, AND NOZZLE HOLDERS

- The inside diameter (ID) of air hoses, fittings, and connections should be at least four times larger than the nozzle orifice size. Blast hose ID should be three to four times the size of the nozzle orifice. Example: a #6 nozzle (3/8" diameter orifice) calls for 1-1/2" ID blast hose and 1-1/2" ID or larger compressor hose. All hose runs should be kept as short as possible and run in as straight a line as possible to reduce pressure loss.
- To install, squarely cut the end of the hose so that it fits snugly against the coupling or hose end shoulder. Always use the screws recommended by the manufacturer ensuring that they do not penetrate the inner wall. Make sure the couplings tightly fit the hose. Install cotter pins at every connection or use couplings with built-in lock-springs to prevent disengagement. Install safety cables at all connections to prevent whipping if hoses disengage or blow out.

MAINTENANCE AND REPAIR

- Completely read and follow all service instructions and recommended maintenance intervals. Always shut off compressor and depressurize blast machine before performing any maintenance. At every service interval, clean all filters, screens, and alarm systems. If spring-loaded abrasive valves are used, always cage spring before disassembly.

WARRANTY

The following is in lieu of all warranties, express, implied or statutory, and in no event shall seller or its agents, successors, nominees or assignees, or either, be liable for special or consequential damage arising out of a breach of warranty. This warranty does not apply to any damage or defect resulting from negligent or improper assembly or use of any item by the buyer or its agent or from alteration or attempted repair by any person other than an authorized agent of seller. All used, repaired, modified, or altered items are purchased "as is" and with all faults. In no event shall seller be liable for consequential or incidental damages. The sole and exclusive remedy of buyer for breach of warranty by seller shall be repair or replacement of defective parts or, at seller's option, refund of purchase price, as set forth below

1. Seller makes no warranty with respect to products used other than in accordance hereunder.
 2. On products seller manufactures, seller warrants that all products are to be free from defects in workmanship and materials for a period of one year from date of shipment to buyer, but no warranty is made that the products are fit for a particular purpose.
 3. On products which seller buys and resells pursuant to this order, seller warrants that the products shall carry the then standard warranties of the manufacturers thereof, a copy of which shall be made available to the customer upon request.
 4. The use of any sample or model in connection with this order is for illustrative purposes only and is not to be construed as a warranty that the product will conform to the sample or model.
 5. Seller makes no warranty that the products are delivered free of the rightful claim of any third party by way of patent infringement or the like.
 6. This warranty is conditioned upon seller's receipt within ten (10) days after buyer's discovery of a defect, of a written notice stating in what specific material respects the product failed to meet this warranty. If such notice is timely given, seller will, at its option, either modify the product or part to correct the defect, replace the product or part with complying products or parts, or refund the amount paid for the defective product, any one of which will constitute the sole liability of the seller and a full settlement of all claims. No allowance will be made for alterations or repairs made by other than those authorized by seller without prior written consent of seller. Buyer shall afford seller prompt and reasonable opportunity to inspect the products for which any claim is made as above stated.
- Except as expressly set forth above, all warranties, express, implied or statutory, including implied warranty of merchantability, are hereby disclaimed.

PREFACE

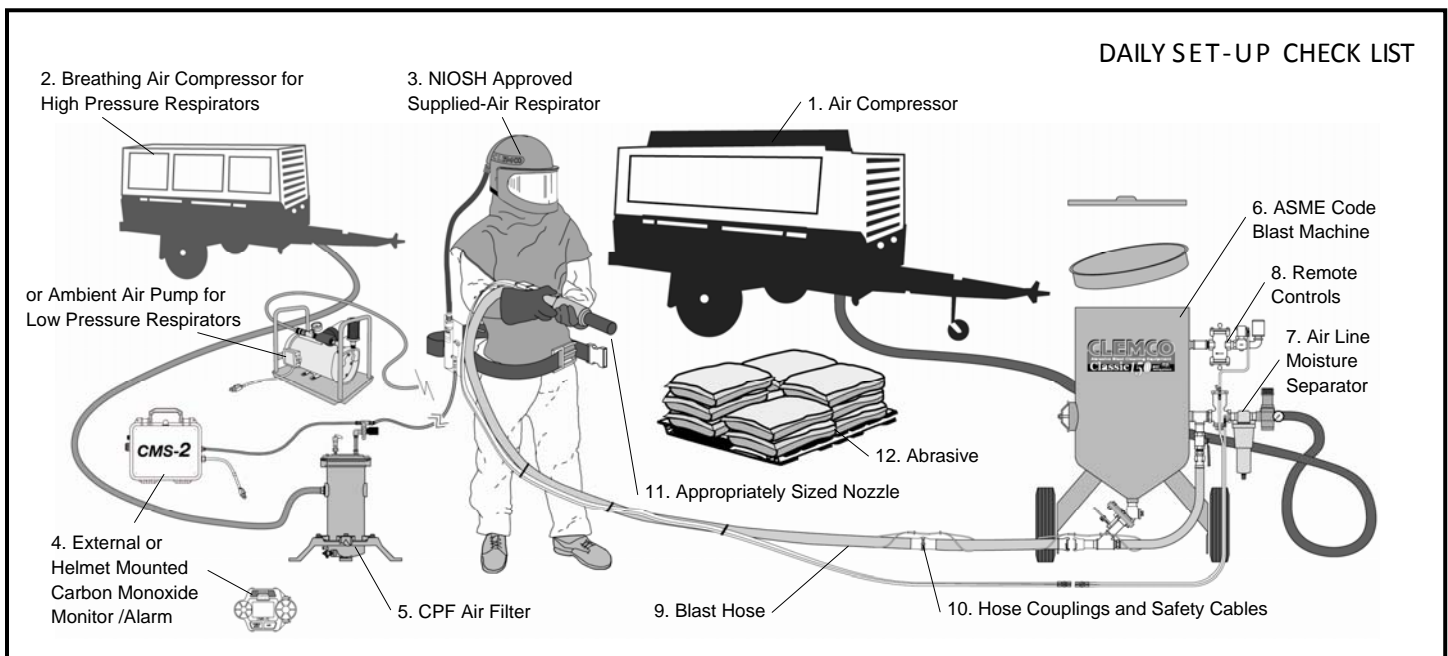

DAILY SET-UP CHECK LIST

Make sure all blast operators are properly trained and suitably attired with a blast suit, safety boots, leather gloves, respiratory and hearing protection. Every day before start up, check all equipment components, including piping, fittings, and hoses, and valves, for leaks, tightness, and wear. Repair or replace as needed. Use the following checklist.

- 1. PROPERLY-MAINTAINED AIR COMPRESSOR** sized to provide sufficient volume (cfm) at given pressure for nozzle and other tools. ADD 50% volume (cfm) reserve to allow for nozzle wear. Use large compressor outlet and air hose (at least 4 times the nozzle orifice diameter). For oil-lubricated compressors, the employer shall use a high-temperature or carbon monoxide alarm, or both, to monitor carbon monoxide levels. If only high-temperature alarms are used, the air supply shall be monitored at intervals sufficient to prevent carbon monoxide in the breathing air from exceeding 10 ppm. Follow the manufacturer's checklist and maintenance instructions.
- 2. BREATHING-AIR COMPRESSOR** (or oil-less ambient air pump) capable of providing Grade D quality air, located in a dust free area. Read # 1 above.
- 3. CLEAN, PROPERLY-MAINTAINED NIOSH-APPROVED SUPPLIED-AIR RESPIRATOR** worn by blast operators, and other workers exposed to blast dust. Make sure all respirator components are in place — all lenses, inner collar, and cape. Thoroughly inspect all components for wear. The NIOSH approval (approval number is listed in the owner's manual) is for a complete assembly from point of attachment on the CPF (sorbet bed) filter to the complete respirator. Substitution of any part voids the NIOSH approval.
- 4. CARBON MONOXIDE MONITOR/ALARM** installed at the CPF filter or inside the supplied-air respirator for monitoring for the presence of deadly CO gas and warning the operator(s) when the CO level reaches an unacceptable level. When an ambient air pump is used for breathing air, a CO monitor provides a measure of safety. Read # 1 above.
- 5. BREATHING-AIR FILTER (OSHA-REQUIRED sorbet bed filter)** for removal of moisture and particulate matter in the compressed air breathing-air supply. Monitor the condition of the cartridge and replace when odor is detected or at 3 month intervals, whichever comes sooner. The breathing air filter does NOT detect or remove carbon monoxide (CO). Always install a CO monitor/alarm.
- 6. BLAST MACHINE** (bearing U or UM stamp, National Board Number, and Maximum Working Pressure) sized to hold a 30-minute abrasive supply. Examine pop-up valve for alignment. Check piping, fittings, screens, valves for tightness, leaks, and wear. Always ground the machine to eliminate hazard of static shock. Install a blast machine screen to keep out foreign objects. Use a blast machine cover if left outdoors overnight. Never exceed the maximum working pressure of the vessel.
- 7. AIR LINE FILTER** (moisture separator) installed as close as possible to the blast machine inlet and sized to match the size of the inlet piping or larger air supply line. Clean filter and drain often. Damp abrasive causes operational problems.
- 8. REMOTE CONTROLS** are required by OSHA and must be in perfect operating condition. Test and check all components to ensure all parts are present and fully functional. Use genuine replacement parts. NEVER mix parts from different manufacturers. Never use welding hose for remote control hose.
- 9. BLAST HOSE** should have an inside diameter sized to suit the blast nozzle. The ID should be three to four times the size of the nozzle orifice diameter. Blast hose should be arranged in as straight a line as possible from the blast machine to the work area, avoiding sharp bends.
- 10. COUPLINGS AND NOZZLE HOLDERS** should fit snugly on the hose and be installed with manufacturer recommended screws. Coupling lugs must snap firmly into locking position. Gasket must always be used to form a positive seal, and cotter pins must be installed. Replace gasket when wear, softness or distortion is detected. Check nozzle holder for thread wear; replace at any sign of wear. Install safety cables at all connections.
- 11. NOZZLE** orifice size should be checked and nozzle replaced when worn 1/16" from original size. (No. 5 nozzle has 5/16" orifice diameter; replace when it measures 3/8"). Threads should be inspected daily for wear and nozzle should be replaced when wear is detected. Always use a nozzle washer.
- 12. ABRASIVE** must be a material specifically manufactured for blasting. It should be properly sized for the job. Check material safety data sheet for free-silica, cyanide, arsenic, lead and other toxins and avoid use when these toxic, harmful substances are present.
- SURFACE TO BE BLASTED** should be examined for hazardous substances. Take appropriate protective measures as required by OSHA to ensure the blast operator, other workers in the vicinity, and any bystanders are properly protected.

©Clemco Industries Corp., Stock No. 20954P, 0692 Rev. F, 06/12

1.0 INTRODUCTION

1.1 Scope of manual

1.1.1 These manual covers the set-up, operation, maintenance, troubleshooting, and replacement parts for the following Clemco Contractor Series Blast Machines with pneumatic Millennium remote controls and abrasive cut-off (ACS):

20" diameter, 4 cu. ft. capacity

24" diameter, 6 cu. ft. capacity

1.1.2 These instructions contain important safety information. All operators and personnel involved with the abrasive blast process must read and understand the contents of these instructions, including the orange cover. It is equally important that the operator is trained and qualified to safely operate the blast machine and remote controls, and all other equipment used with the blast machine.

1.1.3 All personnel involved with the abrasive blasting process must be made aware of the hazards associated with abrasive blasting. The Clemco booklet □Abrasive Blasting Safety Practices□ is included with every blast machine, and contains important safety information about abrasive blasting that may not be included in equipment operation manuals. To order additional copies, visit www.clemcoindustries.com or email info@clemcoindustries.com.

1.2 Safety Alerts

1.2.1 Clemco uses safety alert signal words, based on ANSI Z535.4-2011, to alert the user of a potentially hazardous situation that may be encountered while operating this equipment. ANSI's definitions of the signal words are as follows:



This is the safety alert symbol. It is used to alert you to potential physical injury hazards. Obey all safety messages that follow this symbol to avoid possible injury or death.

NOTICE

Notice indicates information that is considered important, but not hazard-related, if not avoided, could result in property damage.

CAUTION

Caution indicates a hazardous situation that, if not avoided, could result in minor or moderate injury.

WARNING

Warning indicates a hazardous situation that, if not avoided, could result in death or serious injury.

DANGER

Danger indicates a hazardous situation that, if not avoided, will result in death or serious injury.

1.3 Components and Operating Principles

1.3.1 Components

1.3.1.1 The primary components of the Contractor machines are shown in Figure 1. They include the blast machine with Millennium remote controls, pneumatically-operated Auto-Quantum abrasive metering valve, frame assembly, and optional air filters.

1.3.2 Instruction Maintenance Manuals

1.3.2.1 The front leg contains a storage area for owner's manuals. After reviewing all the manuals, and start-up and adjustments are completed, remove the urethane cover plate and store manuals in the compartment, for future reference.

1.3.2.2 Individual manuals are included with optional accessories. Manuals provided with systems include:

- CPF Particulate Air Filter
- Apollo Respirator
- Clem-Cool Air Conditioner

1.3.3 Blast Machine

1.3.3.1 Clemco blast machines (pressure vessels) are certified to conform to the ASME (American Society of Mechanical Engineers) Boiler and Pressure Vessel Code, Section VIII, Division 1. It is the owner's responsibility to maintain the integrity of the vessel in accordance with the requirements of state regulations. Regulations may include regular inspection and hydrostatic testing as described in National Board inspection code and jurisdictional regulations and/or Laws.

⚠ WARNING

Welding, grinding, or drilling on the blast machine could weaken the vessel. Compressed air pressure could cause a weakened blast machine to rupture, resulting in death or serious injury. Welding, grinding, or drilling on the blast machine vessel, without a National Board "R" stamp voids the ASME and National Board certification.

1.3.3.2 All welding repairs to the vessel must be performed by certified welders at shops holding a National Board R Stamp. Welding performed by any welder not properly qualified per the ASME code, voids the Clemco ASME certification.

1.3.3.3 Do not exceed the maximum working pressure rating (PSI) of the blast machine. The maximum pressure rating is stamped into ASME nameplate which is welded to the side of the vessel.

⚠ WARNING

Excessive compressed air pressure could cause a blast machine to rupture. To prevent serious injury or death, do not exceed the rated pressure of the blast machine.

1.3.3.4 Use lifting eyes when raising, loading, and unloading the blast machine. Do not use a sling around the cart handles or piping.

1.3.3.5 The blast machine is equipped with remote controls that allow the operator to pressurize the machine to start blasting, and depressurize it to stop blasting, from a control handle located at the nozzle.

1.3.3.6 OSHA does not require pressure relief valves on blast machines when air compressors supplying air to

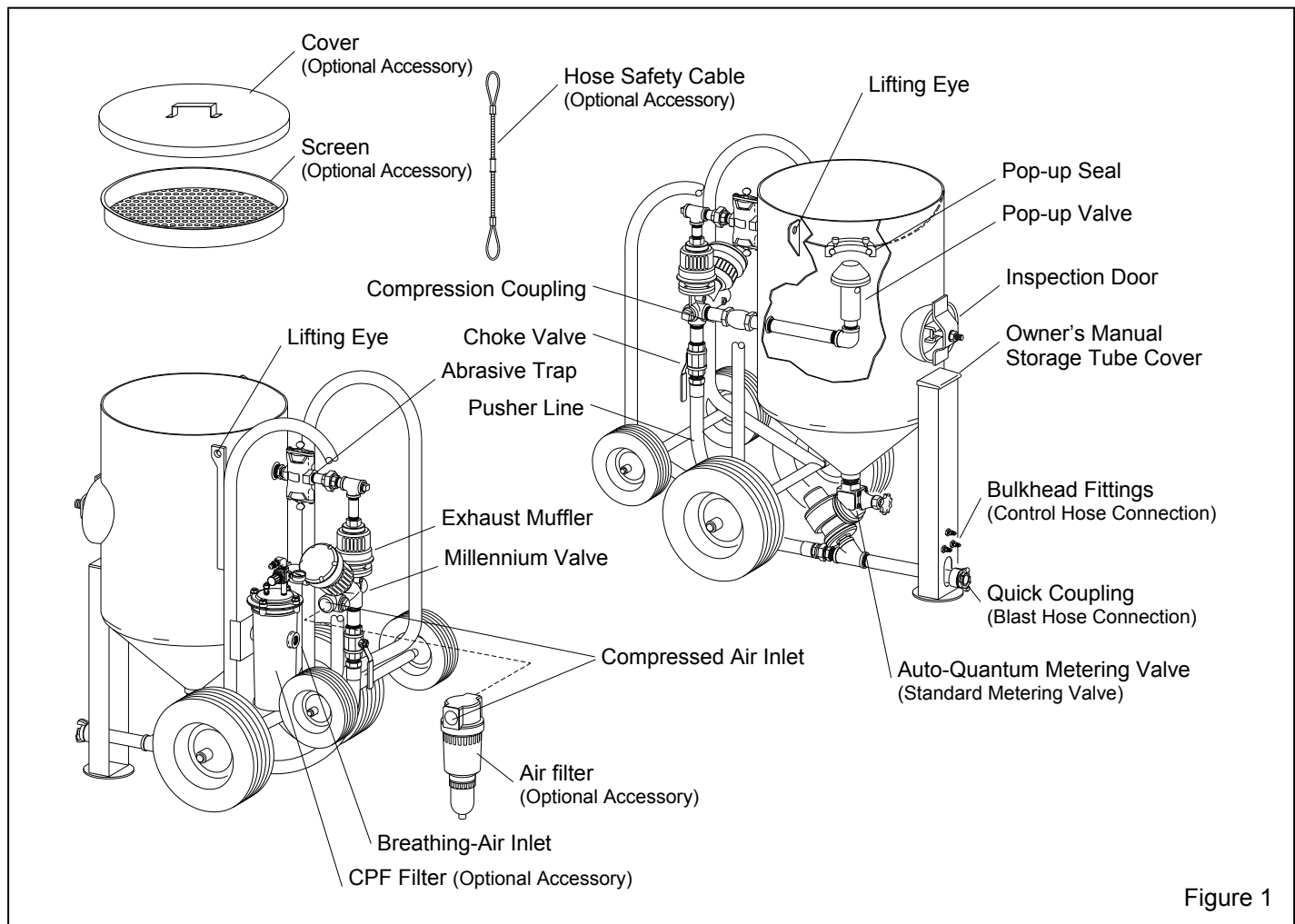

Figure 1

the blast machines are built to ASME⁽¹⁾ code and comply with OSHA⁽²⁾ regulations. OSHA regulation 1910.169 refers to the ASME code when describing the necessity of pressure relief valves on compressed air equipment. **DO NOT** operate blast machines with air compressors that are not equipped with properly-functioning pressure relief valves.

⁽¹⁾ American Society of Mechanical Engineers, Boiler and Pressure Vessel Code, Section VIII, Division 1,

⁽²⁾ Occupational Safety and Health Administration, 29 CFR 1910, 169.

1.3.4 Remote Controls

1.3.4.1 The components of the Millennium remote control system with ACS are shown in Figure 2. They include the Millennium Valve, Auto-Quantum pneumatically-operated abrasive metering valve, RLX Control Handle with ACS air switch assembly, 50-ft. twinline control hose, 50-ft. single-line control hose, 18-in. hose, 4-ft. long twinline control hose, and all necessary fittings.

1.3.4.2 The remote control system is an OSHA-required safety device. The control handle, located near the blast nozzle, is the activator for the remote control system. When the operator intentionally or unintentionally

removes hand-held pressure from the remote control handle, the machine depressurizes, stopping air and abrasive flow through the nozzle. The remote control system "fails to safe", which means when any interruption in the control-air circuit occurs, for reasons such as a break in the line, the compressor stops running, or the operator drops the blast hose, the remote controls deactivate the blast machine.

⚠ WARNING

Never modify or substitute remote control parts. Parts from other manufacturers are not compatible with Clemco equipment. If ANY part of the remote control system is altered, involuntary activation, which may cause serious injury, can occur.

1.3.4.3 Millennium Remote Controls are pressure-release-style systems, which control the pressurization and depressurization of the blast machine. Pressurization, which starts blasting, occurs when the control handle is pressed. Depressurization, which stops blasting, occurs when the handle is released.

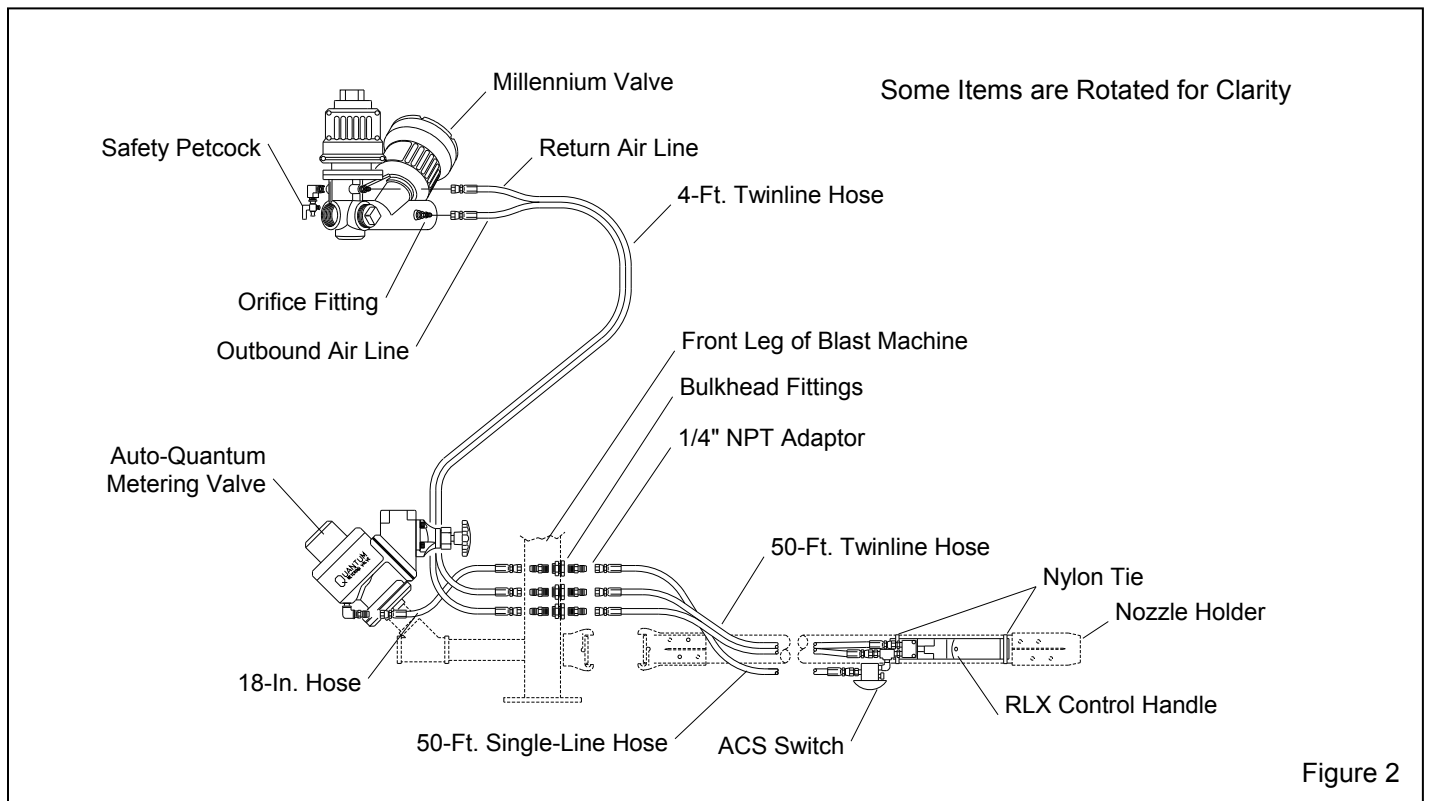

Figure 2

1.3.4.4 Millennium Remote Controls operate pneumatically on the "return air" principle (See Figure 2). One stream of air travels down the outbound twinline and escapes through an opening located under the control handle lever. As long as air escapes through the opening, the remote control system remains inactive. When the lever is pressed, the opening is sealed, and air from the outbound line returns through the return line to open the inlet segment and close the outlet segment of the Millennium valve. This action pressurizes the blast machine and begins the blasting. Releasing the handle exhausts the control air, which closes the inlet segment, and opens the outlet segment to depressurize the machine and stop the blasting.

1.3.5 Abrasive Cut-Off (ACS)

1.3.5.1 The abrasive cut-off switch is mounted on the control handle. The operator uses the switch to close the abrasive valve independently of the air valve, so air without abrasive exits the nozzle.

1.3.6 Electric Remote Control Option

1.3.6.1 Electric remote controls (electro-pneumatic) are recommended when the nozzle and remote control handle are farther than 100 feet from the blast machine. Pressure drop of pneumatic systems over longer distances increases actuation time, which prevents fast, safe operation. Contact your local Clemco Distributor for additional information.

1.3.7 Air Filter, Option

1.3.7.1 The optional filter removes particles and condensed moisture from the compressed air before it enters the machine. Water is drained by use of a manual drain located at the bottom of the filter.

1.3.8 Frame and Cart

1.3.8.1 The frame assembly provides added protection for the piping, valves and accessories. This protection keeps the piping aligned and tight. The wheeled cart assists in the mobility of the machine over smooth flat surfaces. See transporting and moving in Section 3.1.

1.4 Abrasive

⚠ WARNING

Obtain a safety data sheet (SDS) for the blast abrasive. Abrasive blasting with sands containing crystalline (free) silica can lead to serious or fatal respiratory disease. As OSHA recommends, do not use abrasives containing more than trace amounts (more than one percent) free silica.

NOTE: Use only abrasives specifically manufactured for dry blasting and that are compatible with the surface being blasted. Abrasive produced for other applications may be inconsistent in size and shape, and contain particles that could jam the abrasive metering valve, or cause irregular wear, and produce an unsatisfactory finish.

1.4.1 Selection of blasting abrasive can adversely affect the health risk to the operator, productivity, and maintenance of the blast machine. DO NOT USE abrasives containing more than one percent crystalline (free) silica. Obtain safety data sheets (SDS) for the blasting abrasive prior to blasting, paying particular attention to the health risks and presence of any hazardous/toxic substances.

1.4.2 Abrasive Size

1.4.2.1 The choice of abrasive size depends on the desired profile, cleaning rate, nozzle size and availability of clean dry air. Generally, larger and denser abrasives provide a deeper profile, while smaller abrasives clean faster. Most abrasive blasting is done with abrasive sizes between 16 and 80 mesh. Larger sizes may be used if the nozzle orifice is large enough to allow multiple abrasive particles to pass through the nozzle without jamming. Finer abrasives are especially sensitive to moisture and require very dry air to prevent bridging in the metering valve.

1.4.3 Sand: Sand should NEVER be used because of the respiratory hazards associated with the use of abrasive containing free silica.

1.4.4 Slags: Slag abrasives are compatible with the blast machine and accessories. Obtain a material safety data sheets (SDS).

1.4.5 Steel: Steel shot and steel grit may be used. Shot applications may require the use of a pneumatically-operated metering valve such as the Auto-Quantum, to prevent surging at startup.

1.4.6 Silicon Carbide, Aluminum Oxide, and Garnet: These are the most aggressive of the commonly used abrasives. Aggressive abrasives such as these may be used, but the service life of any equipment components which come in contact with the abrasive will be reduced. Use a nozzle lined with boron carbide with these abrasives.

1.4.7 Glass Bead: Most beads are treated to ensure free-flow operation even under moderately high-humidity. Glass beads subjected to excessive moisture may be reused only after thorough drying and breaking up of any clumps. Clean, dry air is a necessity. Glass bead applications may require the use of a pneumatically-operated metering valve, such as the Sentinel or Auto-Quantum, to prevent surging at startup.

1.4.8 Lightweight Abrasive: Plastic media and most agricultural media may be used occasionally in a standard blast machine. Exclusive use of plastic, and some other lightweight media, requires a blast machine with a 60° conical bottom to ensure continuous media flow.

2.0 INITIAL SET-UP

WARNING

Moist air that freezes could cause blockage at the control handle or in the control lines. Blockage could cause involuntary activation of the remote controls, or prevent the controls from deactivating upon release of the control handle. This situation could result in serious injury or death. If remote controls are operated in freezing or near freezing weather, install a Clemco Anti-Freeze Injector, stock no. 05537, on the remote control air supply line.

2.1 Blast Hose and Control Hose Connections, Refer to Figure 2.

NOTE: When using a pressure regulator to reduce blast pressure below 80 psi, relocate the orifice upstream of the regulator and plug the orifice port in the inlet valve. This allows the pneumatic control circuit to operate at line pressure.

2.1.1 Locate the three 1/4" NPT adaptors, packaged in the accessory box. The adaptors are boxed to prevent damage in transit.

2.1.2 Screw the adaptors tightly into the bulkhead fittings on the lower part of the front leg.

2.1.3 Uncoil the blast hose, and lay the 50-ft. twinline hose and 50-ft. single-line hose alongside it. Hoses should be of equal lengths.

2.1.4 Band the control handle to the blast hose close to the nozzle holder, using the two nylon ties provided. Once the control is firmly attached, clip the tie ends so they do not snag the operator's clothing or interfere with the operation of the control handle.

WARNING

Where two or more blast machines are used, carefully trace, connect, and mark, control cord, and blast hose. Cross-connecting control hose or blast hose could lead to serious injury, death, or property damage from unintentional actuation of a blast machine. To prevent cross connections, hoses should be of equal lengths, and the hoses and blast machine couplings clearly marked. Use optional hose identification kits, part no. 15890 for use with two blast machines, or part no. 15891 for up to four machines. Mark each hose and connection per the instructions supplied with the kit, and carefully trace and verify each connection before operating.

2.1.5 Attach the 50-ft. twinline hose to the two fittings on the back of the control handle. Either side of the hose can be attached to either fitting.

2.1.6 Attach the 50-ft. single-line control hose to the fitting on the ACS Switch mounted on the control handle.

2.1.7 Working from the control handle back, band the twinline and single-line hoses to the blast hose every four to six feet, and as close to the couplings as possible.

2.1.8 Place the nozzle washer in the nozzle holder, and screw the nozzle into the holder. The nozzle must seat tightly against the nozzle washer.

2.2 Set up for multiple blast machines operating from a common compressed air supply

2.2.1 Where multiple blast machines are operating from a single air source, install a check valve at the air supply on each machine. The illustration in Figure 3 shows where to install a cone check valve on the blast machine.

2.2.2 If the machines are close together, use a receiver tank or manifold and run separate air lines to each machine. The check valves may be located on the receiver tank outlets. If the airline goes directly to the blast machine and no place else.

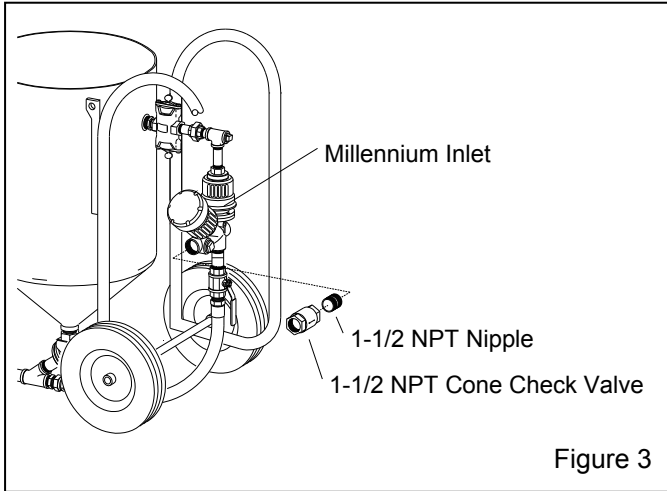

Figure 3

CAUTION

If multiple machines are operating from a common compressed air supply and a machine is under pressure, when another machine is pressurized, the sudden, increased demand for air could reverse air from the machine that is under pressure, and could contaminate the compressed air supply with abrasive laden air. Install check valves at the piping inlet to prevent the reversal of air.

2.2.3 Use a Clemco 1-1/2-NPT cone check valve, stock no. 02296. A smaller size valve could restrict air movement and reduce nozzle pressure. Do not use a swing check valve, which may break in blast machine applications. When installing the valve, make sure the directional arrow is pointing in the direction of the air flow, toward the machine.

2.3 Compressed-Air Supply Hose Connection

2.3.1 Apply thread sealant to the male pipe threads of an air fitting that is compatible with the air supply hose fitting, as noted in Section 2.3.2, and install it onto the 1-1/2 NPT air filter located at the blast machine inlet, or the Millennium inlet valve, as shown in Figure 4. **Note that the style of connection shown in Figure 4 is for reference only.**

WARNING

If twist-on type air hose couplings are used, they must be secured by safety pins or wires to prevent accidental disconnection while under pressure. Hose disconnection while under pressure could cause serious injury.

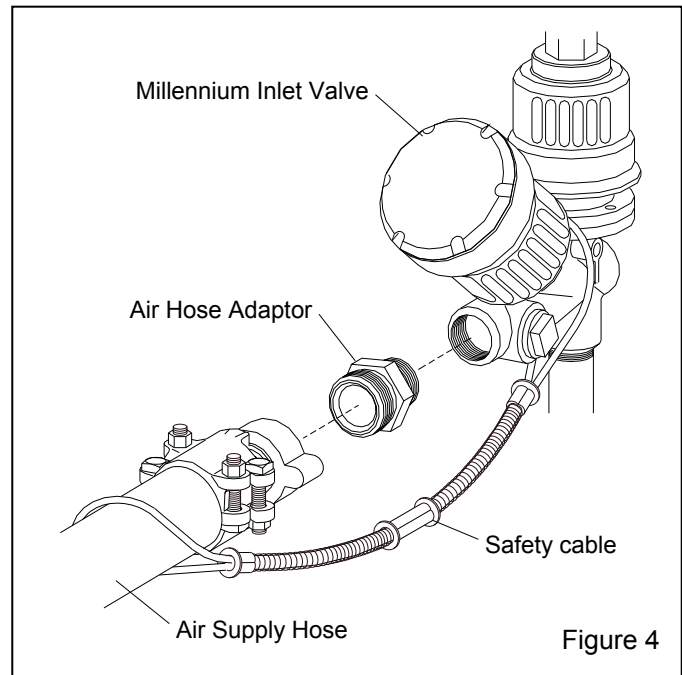

Figure 4

2.3.2 Attach an air line from the compressor to the hose fitting installed on the blast machine inlet. For best blasting performance, use the following guidelines:

Nozzle Orifice Size	Recommended Air Supply Line
No. 3, 3/16"	3/4" ID or larger
No. 4, 1/4"	1" ID or larger
No. 5, 5/16"	1-1/4" ID or larger
No. 6, 3/8"	1-1/2" ID or larger
No. 7, 7/16"	2" ID or larger
No. 8, 1/4"	2" ID or larger

Refer to the compressed air and abrasive consumption table in Figure 7 for approximate air consumption.

2.4 12, Optional CPF

⚠ DANGER

Do not connect the CPF Filter, or any other regulator or filter, to bottled air or any other air source that does not have a pressure-reducing valve that reduces pressure to maximum of 150 psi. Failure to comply with this warning will cause low-pressure devices to explode under the high pressure of bottled air. Such an explosion could cause severe injury or death.

2.4.1 The employer is responsible for ensuring that breathing air shall meet the requirements for Grade D or higher quality, as described in Compressed Gas Association Commodity Specification pamphlet G-7.1., titled Commodity Specification For Air, published by Compressed Gas Association Inc., Chantilly, VA. Website: www.cganet.com (29 CFR 1910.134 (i)).

⚠ WARNING

Air supply to the respirator system is critical to the safety of the user. Read the CPF Filter and Apollo Respirator manuals carefully. Poor quality air will cause serious respiratory injury or death to the user.

2.4.2 Apply thread sealant to the male threads of an air fitting that is compatible with the air supply hose fitting, as noted in Section 2.4.3, and install it onto the 1-NPT port located at the side of the filter, as shown in Figure 5. Note that the style of connection shown in Figure 5 is for reference only.

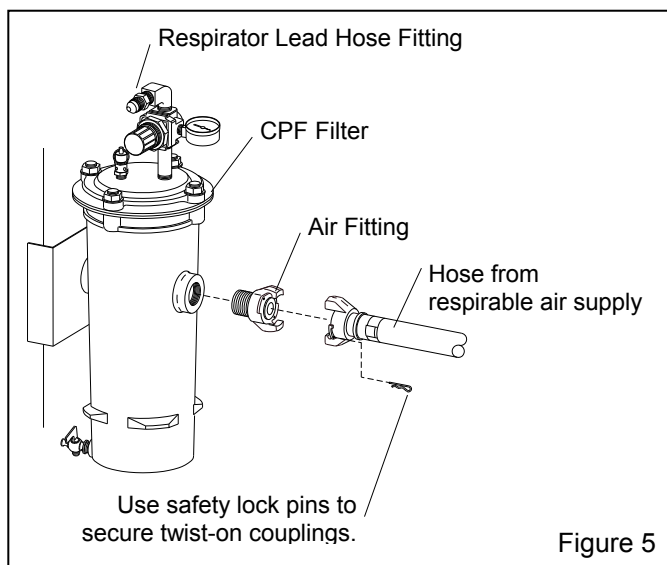

Figure 5

2.4.3 Refer to the CPF air filter owner's manual and connect an air supply hose from an air source that meets OSHA requirements for respirable air, to the fitting installed on the CPF filter inlet, as shown in Figure 5 and noted in the CPF air filter owner's manual.

2.4.4 For models with CPF filter attached, Refer to Figure 25 and connect a hose union to one end of the 5-ft. respirator lead hose and connect the other end of the hose to the fitting at the top of the CPF filter

2.4.5 Refer to the Apollo Respirator and CPF Filter manuals for instructions concerning their operation.

3.0 OPERATION

3.1 Transporting and Moving

3.1.1 Transporting a blast machine

3.1.1.1 Always empty the machine before transporting. Transporting the machine containing abrasive could increase the weight to an unsafe handling limit, and could cause abrasive to settle in piping.

⚠ WARNING

Always empty the blast machine before lifting or hoisting.

- **Use the lifting eyes when lifting the machine. Never hoist the machine by the handle or piping, or with a sling through the handle or piping.**
- **Always use lift equipment that is rated higher than the weight of the machine and accessories.**
- **When transporting a machine on a pallet, always secure the machine to a sturdy pallet.**
- **Always securely anchor the machine to the transport vehicle.**
- **Anyone using material handling equipment to move, transport, or lift the machine must be trained and experienced with the hazards associated with this type of machinery.**
- **Failure to observe these warnings could result in serious injury or death.**

3.1.2 Moving a blast machine

⚠ WARNING

Do not manually move the machine on an incline, or on a slippery or irregular surface that could cause the operator to slip or lose balance. Sudden weight shifts when the machine is tilted on an incline, and slipping or tripping while moving the machine will cause the operator to lose control of the machine, causing severe injury and property damage.

⚠ WARNING

Never attempt to manually move a blast machine when it contains abrasive. An empty machine may be moved when the following criteria are met:

3.1.2.1 An empty machine may be moved manually, on level flat surfaces.

3.1.2.2 To move the machine, push it in a forward direction. Do not back-up while moving the machine, to avoid tripping hazards that may be out of view.

3.1.2.3 Use the lifting eyes when lifting the machine. Do not use a sling around the cart handles or piping.

3.1.2.4 If the machine contains any abrasive, keep the machine upright. Laying down a machine containing abrasive could cause abrasive to lodge in the piping, cause the machine to malfunction or damage valves.

3.2 Start-Up

3.2.1 Locate the compressor upwind from the blasting operation to prevent contaminated air from entering the compressor intake.

3.2.2 Attach an air line from the compressor to the air supply hose connector installed on the blast machine inlet.

3.2.3 Make sure the coupling gaskets are in place and in good condition before connecting the blast hose to the quick coupling on the blast machine. When connecting the hose with Nylon couplings, make sure the coupling spring lock pins are at 180 degrees (Pins should enter the open hole of the adjoining coupling).

The spring lock pins prevent accidental separation of hose couplings during blasting.

3.2.4 Make sure that all compressed-air supply hose connections are secured with safety lock-pins to lock the couplings together and prevent accidental separation while under pressure, and safety cables to prevent hose from whipping should separation occur. Lock pins and safety cables are listed in Section 8.2 of this manual.

⚠ WARNING

Hose disconnection while under pressure could cause serious injury or death. Use safety lock-pins or safety wire to lock the couplings together and prevent accidental separation while under pressure, and safety cables to prevent hose from whipping should separation occur.

3.2.5 Attach the ends of the 50-ft. twinline hose to the lower adaptors in the bulkhead fittings on the front leg as shown in Figure 6. Either side of the twinline hose can be attached to either fitting. Make sure all fittings are tight. Leaks will cause the system to malfunction.

3.2.6 Attach the end of the 50-ft. single-line to the top adaptor as shown in Figure 6. Make sure all fittings are tight. Leaks will cause the system to malfunction.

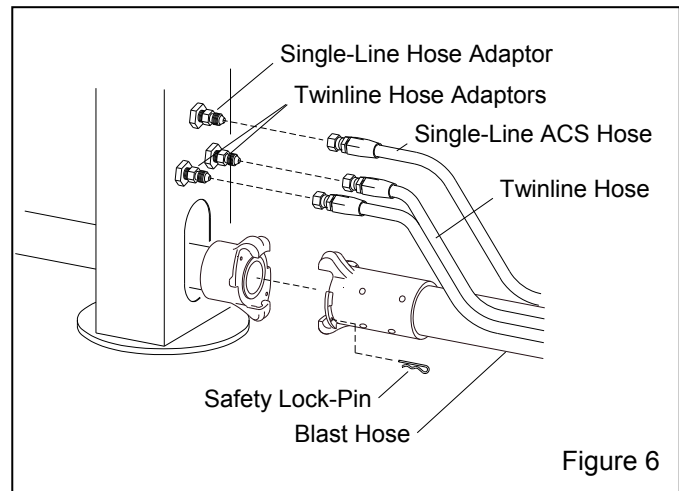

Figure 6

3.2.7 Attach an air line between a source of respirable breathing air meeting the requirements for Grade D or higher quality, and the CPF filter inlet. Refer to Section 2.4. The maximum inlet pressure for the CPF Filter must not exceed 150 psi.

Compressed Air and Abrasive Consumption									
Consumption rates are based on abrasive that weigh 100 pounds per cubic foot									
Nozzle Orifice Size (in.)	Pressure at the Nozzle (psi)								Air, Power and Abrasive Requirements
	50	60	70	80	90	100	125	140	
No. 2 1/8"	11	13	15	17	19	20	25	28	Air (cfm)
	67	77	88	101	112	123	152	169	Abrasive (lbs/hr)
	2.5	3	3.5	4	4.5	5	5.5	6.5	Compressor (hp)
No. 3 3/16"	26	30	33	38	41	45	55	61	Air (cfm)
	150	171	196	216	238	264	319	353	Abrasive (lbs/hr)
	6	7	8	9	10	10	12	14	Compressor (hp)
No. 4 1/4"	47	54	61	68	74	81	98	108	Air (cfm)
	268	312	354	408	448	494	608	676	Abrasive (lbs/hr)
	11	12	14	16	17	18	22	24	Compressor (hp)
No. 5 5/16"	77	89	101	113	126	137	168	186	Air (cfm)
	468	534	604	672	740	812	982	1085	Abrasive (lbs/hr)
	18	20	23	26	28	31	37	42	Compressor (hp)
No. 6 3/8"	108	126	143	161	173	196	237	263	Air (cfm)
	668	764	864	960	1052	1152	1393	1538	Abrasive (lbs/hr)
	24	28	32	36	39	44	52	59	Compressor (hp)
No. 7 7/16"	147	170	194	217	240	254	314	347	Air (cfm)
	896	1032	1176	1312	1448	1584	1931	2138	Abrasive (lbs/hr)
	33	38	44	49	54	57	69	77	Compressor (hp)
No. 8 1/2"	195	224	252	280	309	338	409	452	Air (cfm)
	1160	1336	1512	1680	1856	2024	2459	2718	Abrasive (lbs/hr)
	44	50	56	63	69	75	90	101	Compressor (hp)

- For nozzle sizes 3/8" to 1/2", blast machines should be equipped with 1-1/4" or larger piping and inlet valve to prevent pressure loss.
- Air requirements were measured by a flow meter under actual blasting conditions, and are therefore lower than figures for air alone, with no abrasive.
- Horsepower requirements are based on 4.5 cfm per horsepower.
- Figures are for reference only, and may vary for different working conditions. Several variables, including metering valve adjustments, can affect abrasive flow.
- Figures show approximate compressed air and abrasive consumption when nozzles are new. Consumption will increase as the nozzle wears.

Figure 7

 DANGER

Do not connect the CPF Filter, or any other regulator or filter, to bottled air or any other air source that does not have a pressure-reducing valve that reduces pressure to maximum of 150 psi. Failure to comply with this warning will cause low pressure devices to burst from the excessive pressure of bottled air. A rupture of this nature could cause severe injury or death.

2.2.8 Make sure that all blast hose and compressed-air hose connections are secure, and that coupling lock pins are in place.

3.2.9 Make sure the choke valve is open, (handle position aligned with the valve and piping).

 WARNING

If twist-on type air hose couplings are used, they must be secured by safety pins or wires to prevent accidental disconnection. Hose disconnection while under pressure could cause serious injury or death.

3.2.10 Close the Quantum abrasive metering valve. Closed position is when the knob has been turned fully clockwise. See Section 4.1.

3.2.11 Open the safety petcock on the inlet section of the Millennium valve and on the Quantum metering valve actuator. The petcock is open when the lever is in-line with the petcock, as shown in Figure 8.

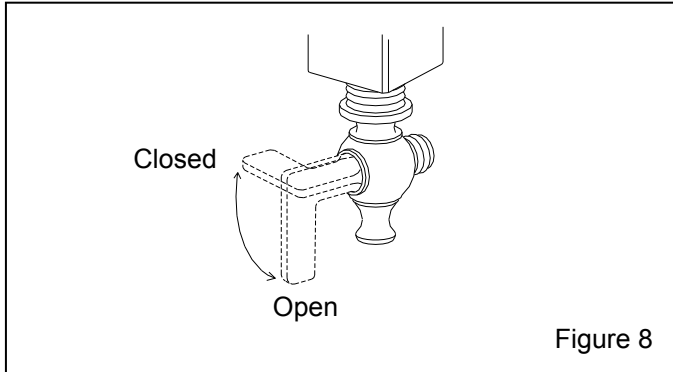

⚠ WARNING

To prevent severe injury or death from accidental activation of the blast machine, open the safety petcock when the blast machine is not in use. Opening the petcock prevents unintentional blasting. The control handle cannot activate the machine when the petcock is open.

3.2.12 Make sure the control handle lever is in the up (no blast) position, as shown in Figure 9 and that the handle lever and safety lock move freely.

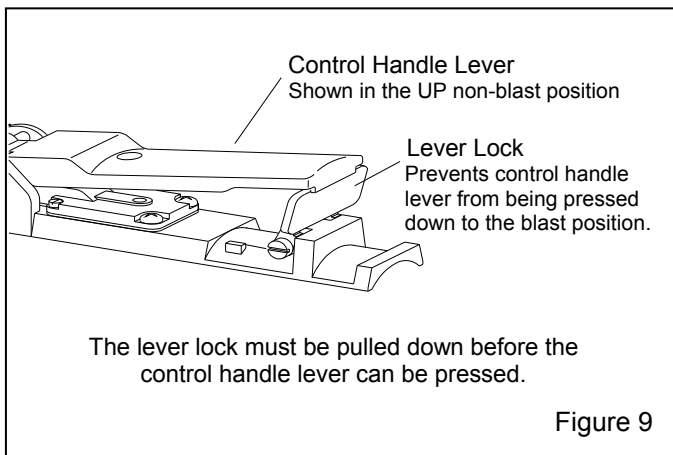

3.2.13 Make sure the handle lever does not seal the opening on the control handle, unless the safety lever lock is intentionally pulled down.

⚠ WARNING

Malfunctioning control handles could cause unintentional actuation of a blast machine, or prevent a machine from deactivating upon release. Malfunctioning control handles must be taken out of service immediately and repaired or replaced. Serious injury or death can result from unintentional blasting.

3.2.14 Close the air valve on the compressor. Start the compressor, and bring it to operating temperature and pressure. The pressure must be more than 30 psi, but not exceed 150 psi.

3.2.15 Slowly open the compressor air valve to pressurize the air line. Listen for any open lines or leaks.

3.2.16 Pressurize the breathing air supply line, and adjust pressure on the CPF Filter outlet to the pressure stated in the respirator manual.

3.2.17 Load abrasive into the machine according to the instructions in Section 3.8.

3.2.18 Do not allow anyone around the blast machine except machine tenders, who are appropriately attired in approved protective equipment.

⚠ WARNING

Everyone except for the blast operator or blast machine tender must stay clear of the blast machine. The machine tender or blast operator may pressurize or depressurize the machine at any time, which could cause abrasive to vent under pressure, causing dust and toxins to become airborne. Noise is produced by the sudden release of compressed air when the machine is pressurized or depressurized. These conditions could cause injury. Both the operator and machine tender must wear suitable personal protective equipment including an approved respirator, plus approved eye, face, and hearing protection.

3.2.19 When the blast operator is ready to blast, the operator or the machine tender, must stand back and face away from the concave filling head of the blast machine and the exhaust muffler, and close the safety petcock. Closing the petcock prepares the machine for remote operation and activation by the control handle. Air should be heard escaping from the orifice under the control handle lever but nowhere else. The air escaping

at the control handle is an audible signal meaning air is supplied to the blast machine, which will activate when the control handle is pressed.

3.3 Blasting Attire

3.3.1 Operators and anyone else that may be exposed to the hazards generated by the blasting process must wear appropriate protective gear, including abrasive-resistant clothing, leather gloves, eye and hearing protection, and a NIOSH-approved Type CE Supplied-Air Respirator.

⚠ WARNING

Before blasting, test the coating and substrate for toxic materials (such as lead or other heavy metals, or asbestos). These hazards require special measures to protect the operators and the environment.

No dust is safe to breathe. Abrasive blasting produces harmful dust. Failure to wear approved respirators could result in serious lung disease or death. Blast operators must wear properly-fitted and maintained NIOSH-approved, type-CE supplied-air respirators approved for abrasive blasting.

During abrasive blasting, abrasive particles and dust in the area around the blast machine and blast nozzle become airborne. Everyone working in the vicinity of abrasive blasting must wear properly-maintained, NIOSH-approved, respiratory protection and eye protection appropriate for the job site hazards.

Loud noise generated by the use of compressed air could cause hearing damage. Everyone in the blasting area must wear approved hearing protection.

3.4 Blasting

3.4.1 Don all protective, blasting attire, per Section 3.3.

3.4.2 Hold the blast hose securely and point the nozzle only toward objects intended to be blasted.

3.4.3 Fold down the safety lever lock and press the remote control handle as shown in Figure 10. Within a few seconds, the pop-up valve will automatically close, and the blast machine will pressurize to start blasting.

⚠ CAUTION

Be prepared for recoil from the blast hose. Blasting should begin within a few seconds after pressing the control handle lever.

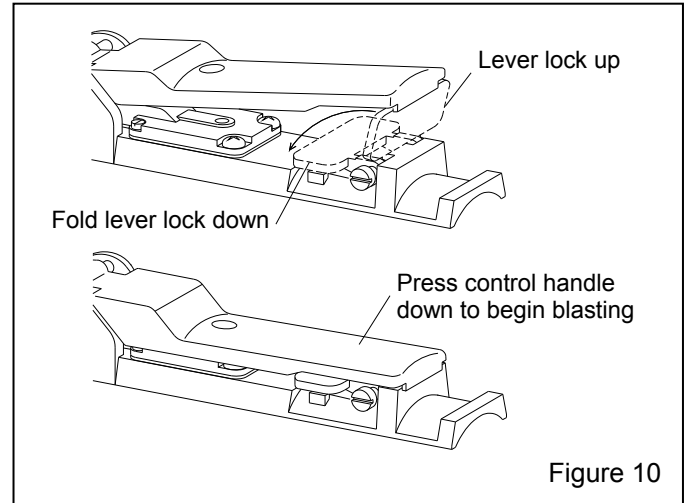

⚠ WARNING

OSHA requires the use of remote controls on all blast machines when an operator controls the nozzle. To comply with OSHA regulations, the remote control handle, which starts and stops the flow of air and abrasive, must be held down manually. Never tie down the control handle lever or attempt to bypass any part of the remote control system. Doing so will defeat the purpose of the fail-to-safe feature of the remote control. Serious injury or death could result from uncontrolled blasting. Ref. 29 CFR 1910.244 (b).

3.4.4 Make sure the toggle on the ACS switch is pointing away from the nozzle to open the Quantum metering valve. Refer to Section 3.6 for operation of the ACS.

3.4.5 Adjust abrasive flow per Section 4.1.

3.5 Operation and Function of the Choke Valve Refer to Figure 11

3.5.1 Always fully open the choke valve while blasting; open is when the handle is vertical and aligned with the piping as shown in Figure 11.

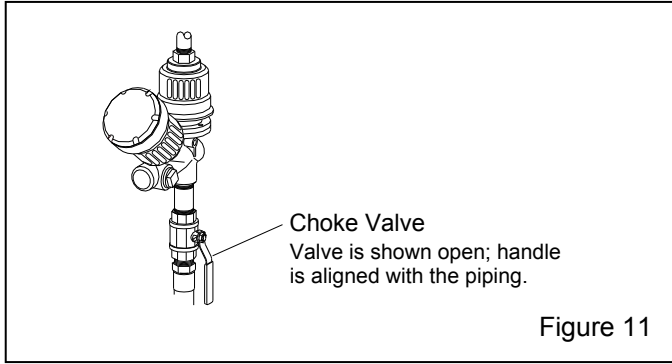

Figure 11

3.5.2 Closing the choke valve while blasting, lowers pressure in the pusher line from the pressure in the vessel. Closing the choke valve clears the valve of minor blockage such as damp abrasive, or is used to rapidly empty the machine at the end of the day.

NOTICE

Do not blast with choke valve closed or partially closed. Prolonged blasting with the choke valve partially closed will accelerate wear on the metering valve.

3.6 Operation of Abrasive Cut-Off Switch (ACS)

⚠ WARNING

OSHA sets exposure limits for people and the environment. Airborne dust could increase the exposure levels beyond permissible limits. OSHA prohibits blowing with compressed air as a cleaning method for lead-based paint dust or other hazardous dust, unless the compressed air is used in conjunction with a ventilation system designed to capture the volume of airborne dust created by the compressed air, 29 CFR 1926 (h). The ACS is for blowing off abrasive from a blasted surface, NOT as a general area clean-up tool.

3.6.1 The ACS serves two purposes:

1. Clearing abrasive from the blast hose when blasting is finished. This is helpful in a lot of applications and necessary when blasting vertical, to prevent abrasive from collecting in low spots in the blast hose, eliminating excessive abrasive slugging at startup.
2. Blow abrasive off the blasted surface. NOTE: Small amounts of residual abrasive may exit the nozzle with the air, requiring blowing off or otherwise cleaning surface outside the blasting area prior to painting.

3.6.2 The abrasive cut-off switch is situated directly behind the control handle. The switch may be flipped open or closed at any time, but will not operate the metering valve unless the control handle is pressed.

3.6.2.1 Blast Mode Moving the ACS toggle away from the nozzle to the "ON" ("CYL" port) position, as shown in Figure 12, sends control-air to the abrasive metering valve, opens the valve and the blast machine operates normally, with air and abrasive coming out the nozzle.

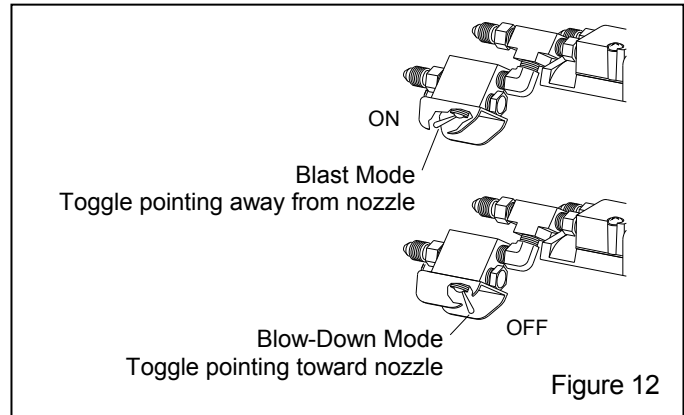

Figure 12

3.6.2.2 Blow-Down Mode Moving the ACS toggle toward the nozzle, to the "OFF" position, cuts off the control-air to the abrasive metering valve, closes the valve and stops the abrasive flow. This action allows air alone to exit the nozzle, useful for clearing the blast hose before shutting down, and blowing abrasive off the blasted surface.

3.7 Stop Blasting

3.7.1 Before releasing, the control handle, the operator may use the ACS to stop the abrasive flow to clear the blast hose, and if conditions permit, blow-down the work piece. Refer to Section 3.6 for operation of the ACS.

3.7.2 To stop blasting; release the control handle lever. The outlet section of the Millennium valve opens, and the blast machine depressurizes. The pop-up valve automatically drops when air is expelled from the machine and pressure equalizes.

3.7.3 When the control handle lever is released, the safety lever-lock will flip up to lock the handle lever in the up (no blast) position. Make sure the safety lever-lock is up to prevent the handle lever from engaging.

3.7.4 Always open the safety petcock during work breaks and before filling the blast machine. Opening the petcock prevents unintentional blasting.

3.7.5 When finished blasting, shutdown per Section 3.10.

3.8 Loading Abrasive into the Blast Machine

WARNING

When approaching an idle blast machine, and before loading the blast machine with abrasive, always make sure the safety petcock is open. If it is closed, open it while standing back and facing away from the concave head and exhaust muffler. This step is especially important if one worker (a machine tender) loads the machine with abrasive while another worker (the blast operator) controls the blasting. The blast operator could pressurize the machine before the machine tender has moved away from the machine. During pressurization, abrasive could be forced out of the top of the machine, and cause injury.

3.8.1 Load abrasive by pouring it into the concave head. Use a screen (screen comes with blast machine packages) placed over the head to prevent objects from falling inside. Foreign objects will jam the machine. Abrasive flows through the filling port into the machine. Keep the abrasive level below the pop-up valve to prevent abrasive above the pop-up valve from being forced up and out of the machine when it pressurizes.

3.8.2 When the ready to blast, the operator or machine tender, while standing back and facing away from the concave filling head and exhaust muffler, closes the safety petcock.

3.8.3 Begin blasting or resume blasting per Section 3.4.

3.9 Emptying the Machine of Abrasive

3.9.1 When working in environments subject to extreme temperature changes, or very humid conditions, condensation may develop inside the machine. Condensation dampens abrasive and causes flow problems. To prevent this, empty the machine of abrasive when shutting down for the day. This will eliminate trouble from moist abrasive when starting a new day's blasting. One way to avoid having to empty the machine is to load only as much abrasive as will be used during the work period. If the machine must be purged of abrasive, do the following.

3.9.2 With the blast machine off, turn the blast pressure down to approximately 40-50 psi, close the choke valve and set the abrasive metering valve at full open.

3.9.3 To prevent rapid wear of the nozzle holder threads, the nozzle should be firmly attached to the nozzle holder. Removing the nozzle is discouraged. If circumstances require the nozzle to be removed, also remove the nozzle washer. Purging the machine without a nozzle in place will erode the thread area of the nozzle holder, which could cause a hazardous condition.

WARNING

The threads on the nozzle and nozzle holder must be inspected each time the nozzle is secured to the holder. A loose-fitting nozzle may eject under pressure and could cause severe injury. Check the threads for wear, and make sure the nozzle holder securely holds the nozzle. The nozzle washer must also be inspected for wear. When nozzle washers are worn, abrasive could erode nozzle threads.

3.9.4 Point the nozzle into a drum or suitable container, or in the direction of the abrasive disposal site.

3.9.5 Hold the hose securely and pressurize the machine by activating the control handle. Be prepared for severe surging, or recoil of the hose.

3.9.6 When the machine is empty, release the control handle lever, open the safety petcock, and open the choke valve.

3.9.7 If the nozzle was removed, thoroughly inspect the nozzle holder threads for wear before installing the nozzle washer and attaching the nozzle.

3.10 Shutdown

3.10.1 Empty the blast machine per Section 3.9.

3.10.2 When finished blasting, and after cleanup is completed, remove the respirator outside the respirator-use area where the air is safe to breathe.

3.10.3 Close the compressed-air supply valve at the compressor.

3.10.4 Drain receiver tank, air filter, and water collecting devices, and bleed the compressed-air supply hose.

3.10.5 Shutdown the compressor.

3.10.6 Cover the blast machine when not in use. Refer to Section 8.1 for optional covers.

4.0 ADJUSTMENTS

4.1 Abrasive Metering, Figure 13

4.1.1 Abrasive flow is adjusted at the metering valve located at the bottom of the blast machine. Use the metering knob to adjust abrasive flow.

4.1.2 The hole in the knob enables the operator to monitor its rotation and count turns as the knob is turned. This helps to return the setting to its original position, if temporary adjustments are required.

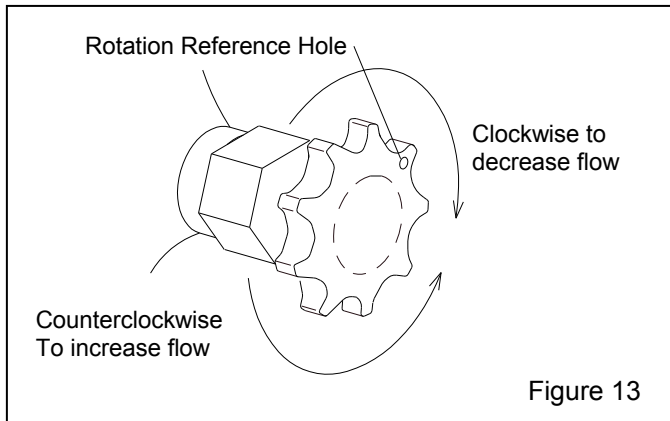

4.1.3 The valve is closed when the knob is turned fully clockwise. Begin with the knob set 1-1/2 turns from fully closed. While the operator is blasting, the machine tender turns the knob no more than 1/4 turn counterclockwise to increase abrasive flow. Allow 10 to 15 seconds for the flow to stabilize before readjusting. Continue making adjustments as described until correct flow is attained.

4.1.4 Optimum abrasive flow depends on the type and size of abrasive and blasting pressure, and can best be determined by experience. Use as little abrasive as possible while maintaining the maximum cleaning rate. The air/abrasive mixture should be mainly air. As a rule, the stream of abrasive coming out of the nozzle should barely discolor the air when seen against a contrasting background.

5.0 PREVENTIVE MAINTENANCE

5.1 Daily Inspection

5.1.1 With the air off, before blasting, do the following:

- Empty the abrasive trap and clean the abrasive trap screen. Do this at least twice a day, or more often if the machine is frequently cycled. Failure to clean the abrasive trap on a regular basis is a major cause of system malfunction. See Section 6.8.
- Check to make sure that couplings are secure and lock pins and safety cables are in place.
- Make sure the nozzle washer is in place and not worn.

⚠ WARNING

The threads on the nozzle and nozzle holder must be inspected each time the nozzle is secured to the holder. A loose-fitting nozzle may eject under pressure and could cause severe injury. Check the threads for wear, and make sure the nozzle holder securely holds the nozzle. The nozzle washer must also be inspected for wear. When nozzle washers are worn, abrasive could erode nozzle threads.

- Inspect the RLX control handle; look for the following:
 - The lever must not seal the opening on the control, unless the safety lever lock is pulled down.
 - The **handle lever** must return to the "up" position when released.
 - The **safety lever lock** must return to the "up" position when the handle lever is released.
 - Both the handle lever and safety lever lock must move freely with no drag or binding.

⚠ WARNING

Malfunctioning control handles could cause unintentional actuation of a blast machine, or prevent a machine from deactivating upon release. Malfunctioning control handles must be taken out of service immediately and be repaired or replaced. Serious injury or death can result from unintentional blasting.

5.1.2 Do the following during blasting:

- Check the control handle for leaks.
- Inspect all couplings and coupling gaskets for leaks.
- Check the blast machine for leaks. If leaks are found around the pop-up valve, inspection door, or pipe fittings at the bottom of the cone,

NOTICE

If leaks are allowed to continue, abrasive erosion could cause extensive or irreparable damage to the blast machine.

- Check all external piping, control hoses, and valves for leaks. If leaks are found, stop blasting and repair.
- Inspect blast hose, couplings, and nozzle holders for leaks. At the first sign of a leak, stop blasting and inspect all items for wear.

⚠ WARNING

Leaks around couplings and nozzle holders indicate worn or loose-fitting parts. Nozzle holders and couplings that do not fit tight on hose, and nozzles that do not fit tight in nozzle holders could disconnect while under pressure. Impact from nozzles, couplings, hoses, or abrasive, from parts disconnected by pressure during operation could cause severe injury.

5.2 Weekly Inspection

5.2.1 With the air off, before blasting, do the following:

- Inspect the blast hose for wear; look for soft spots. Soft spots mean the hose is worn. Replace the blast hose before the tube wears as far as the fabric plies.

⚠ WARNING

Worn blast hose could suddenly burst. Couplings and nozzle holders may not adequately grip worn hose causing them to blow-off under pressure. Compressed air and abrasive escaping from a burst hose, or disconnected coupling or nozzle holder, could cause severe injury.

- Remove the nozzle for inspection. Replace with a new nozzle if the orifice diameter is worn 1/16" or more, or if the liner is cracked.
- When an optional air filter is used, inspect the filter element, and clean the bowl.

5.2.2 During blasting do the following:

- Note the time it takes to fully depressurize the machine after the control handle is released. When depressurizing time increases noticeably, inspect the exhaust muffler per Section 6.5.

5.3 Monthly Inspection

5.3.1 With the air off, before blasting, do the following:

- Check the pop-up valve's urethane coating for cracks and grooves. Replace the pop-up valve at the first sign of wear. Refer to Section 6.10.
- Inspect the rubber pop-up seal, and replace at the first sign of wear, drying, or cracking. Refer to Section 6.11.

5.4 Periodic Inspection

5.4.1 Millennium Control Valves: For safety and to avoid unscheduled downtime, periodically inspect the internal parts of the inlet and outlet valves, Quantum valve, and abrasive trap. Inspect for wear and lubrication on o-rings, pistons, springs, seals, and castings. Refer to Service Maintenance Sections 6.3, 6.4, 6.5, 6.6, 6.7 and 6.8.

5.4.2 Auto Quantum metering: For safety and to avoid unscheduled downtime, periodically inspect the internal parts of the Quantum actuator and metering assembly. Inspect for wear and lubrication on o-rings, pistons, springs, seals, and castings. See Service Maintenance in Sections 6.6 and 6.7.

5.4.3 RLX Control Handle: Periodically clean around the springs, handle lever, and lever lock to ensure that the unit is free of abrasive and debris that may cause the handle lever or lever lock to bind. See Section 6.9.

6.0 SERVICE MAINTENANCE

WARNING

Failure to observe the following before performing any maintenance could cause serious injury or death from the sudden release of compressed air.

- Depressurize the blast machine.
 - Lock-out (Be certain the air supply is off and that it cannot be started while work is in process) and tag-out (Be certain the air supply is clearly marked to prevent re-starting while work is in process) the compressed air supply
 - Bleed the air supply line to the blast machine.
-

6.1 Removing Damp Abrasive From the Blast Machine.

6.1.1 To clear a minor blockage caused by damp abrasive, during operation, rapidly open and close the choke valve several times.

6.1.2 For blockages that are more difficult, proceed as follows: See Section 6.2 to check obstructions in metering valve.

6.1.2.1 With the blast machine depressurized disconnect the blast hose and remove the gasket from the quick coupling on the machine.

6.1.2.2 Place the machine so that the outlet is pointed away from any objects or persons.

WARNING

The machine's outlet must be pointed away from any objects or persons. Stand clear of the path of exiting abrasive. It may come out at high velocity. Impact from exiting abrasive could cause severe injury.

6.1.2.3 Close the choke valve and fully open the abrasive metering valve. Pressurize the machine to force out any damp abrasive.

6.1.2.4 When the obstruction has been removed, depressurize the machine. Remove the nozzle and nozzle washer, and reconnect the hose. Open the choke

valve and close the abrasive metering valve. Pressurize the machine to clear the hose. When the hose is cleared, depressurize the machine and attach the nozzle washer and nozzle.

WARNING

The threads on the nozzle and nozzle holder must be inspected each time the nozzle is secured to the holder. A loose-fitting nozzle may eject under pressure and could cause severe injury. Check the threads for wear, and make sure the nozzle holder securely holds the nozzle. The nozzle washer must also be inspected for wear. When nozzle washers are worn, abrasive could erode nozzle threads.

6.1.2.5 With the hose cleared, start the machine using normal procedures.

6.2 Clearing Obstructions in the Abrasive Metering Valve and Blast Machine.

6.2.1 If the nature of the obstruction permits emptying the machine of abrasive, do so by following the instructions per Section 3.9.

6.2.2 Turn off the compressed air supply. Lockout and tagout the air supply, and bleed the air supply line to the blast machine.

6.2.3 Remove the wing nuts securing the abrasive metering valve's cleanout cover.

6.2.4 Check the metering valve for blockage, by inserting fingers into the opening to feel for an obstruction or foreign object.

6.2.5 If the metering valve is clear, remove the blast machine inspection door, and check inside for foreign objects.

6.2.6 Make sure the inspection door gasket is in good condition and in place before bolting the door onto the machine.

6.2.7 Make sure the abrasive metering valve cleanout cover o-ring is in good condition and in place before reassembling the cleanout cover.

6.2.8 Check to make sure all inspection doors are secure before starting the air supply.

6.3 Millennium Valve Inlet Segment, Figure 14.

NOTE: Two service kits are available for the Millennium valve inlet segment. To avoid unscheduled downtime, keep both kits on-hand. Replace all the seals provided in the seal service kit whenever the valve is opened. Use the plunger tip kit when replacing the plunger tip.

6.3.1 Unscrew the six socket head screws to remove the cylinder cap, cylinder cap gasket, and spring.

6.3.2 Remove the cylinder sleeve by screwing two 1/4-NC screws into the holes in the end of the sleeve and by pulling the screws to remove the sleeve from the body. If the sleeve is too tight to remove by hand, use a puller. Remove the screws after the sleeve is removed.

6.3.3 To remove the piston, screw a 1/4-NC screw into the center of the socket head screw, grip the screw, and pull out. If the piston is too tight to remove by hand, use a puller. Remove the screw after the piston is removed.

6.3.4 It is not necessary to separate the plunger from the piston unless the metal of either part is scored. To remove the plunger, insert a rod through the hole in the lower part of the plunger. Hold the rod to prevent the plunger from turning, while using a 5/16" hex key to remove the socket screw from inside the piston.

6.3.5 If the plunger tip is worn, use a 3/16" hex key to remove the button screw, washer and tip.

6.3.6 Clean all items and inspect for wear. Replace all seals and o-rings (they are included in the service kit), and replace all worn or damaged parts.

- Inspect the plunger tip. Replace the tip if worn or damaged.
- Inspect the machined plunger seat in the valve body for wear. The body must be replaced if the seat is worn.

6.3.7 If the plunger and piston were separated as noted in paragraph 6.3.4, apply removable thread sealant to the socket head screw, and reassemble the parts using a new o-ring supplied with the service kit.

6.3.8 Lubricate o-rings and u-seals with a silicone-based lubricant.

6.3.9 Replace both o-rings in the valve body.

6.3.10 Place the u-seals into the grooves on the piston, the open side of the large seal faces the plunger, and the open side of the small one faces away from the plunger, as shown in Figure 14.

6.3.11 Install the plunger and piston assembly into the body. Make sure the open side of the large (lower) u-seal does not fold back during assembly. Tucking the lip of the seal in, while applying pressure to the piston eases assembly.

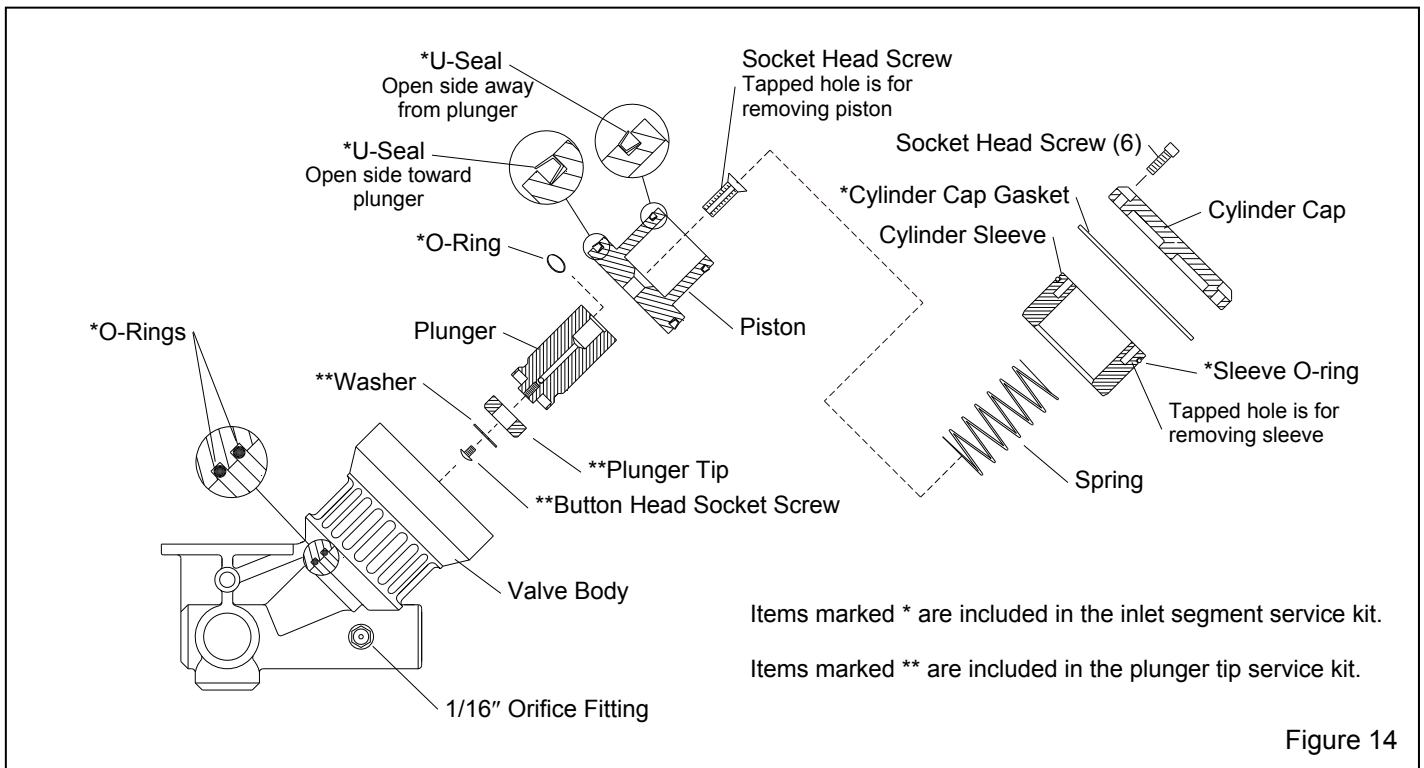

Figure 14

6.3.12 Place the o-ring on the cylinder sleeve, and insert the sleeve (o-ring end up) into the body, making sure the open side of the small (upper), piston u-seal does not fold back during assembly.

6.3.13 Install the spring, cylinder cap gasket, and cylinder cap.

6.3.14 Tighten the six socket head screws in sequence to secure the cap.

6.3.15 If fittings on the body were removed, make sure the 1/16" orifice fitting is threaded into the port, as shown in Figure 14.

6.4 Millennium Valve Outlet Segment, Figure 15

NOTE: Two service kits are available for the Millennium valve outlet segment. To avoid unscheduled downtime, both kits should be kept on-hand. Replace all the seals provided in the service kit whenever the valve is opened, or when replacing the diaphragm. Use the muffler service kit when replacing the muffler.

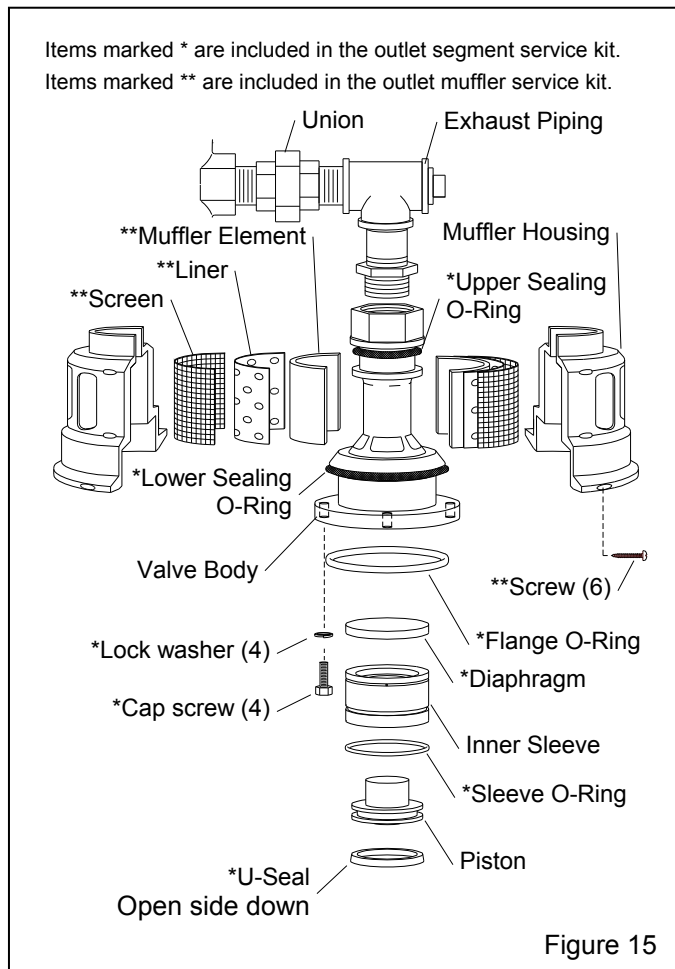

Figure 15

6.4.1 Loosen the exhaust piping union nut.

6.4.2 Unscrew the four hex head cap screws securing the outlet body to the inlet, and remove the exhaust assembly.

6.4.3 Screw a 1/4-NC screw into the threaded hole in the bottom of the piston. Grip the screw, and pull out to remove the piston. Remove the screw after the piston is extracted.

6.4.4 Screw 1/4-NC screws into the threaded holes in the bottom of the inner sleeve. Grip the screws, and pull out to remove the sleeve. Remove the screws after the sleeve is extracted.

6.4.5 Remove the diaphragm from the bottom of the exhaust valve body.

6.4.6 Clean all items and inspect for wear. Replace the diaphragm, seals and o-rings (they are included in the service kit), and replace all worn or damaged parts.

- Place the piston into the inner sleeve and check movement. If the parts drag, or if abraded or worn they must be replaced.
- Inspect the machined seat in the exhaust body for wear. The body must be replaced if the seat is worn.

6.4.7 Inspect the exhaust muffler per Section 6.5.

6.4.8 Lubricate the u-seal with a silicone-based lubricant, and place the u-seal into the groove in the piston. The open side of the seal must face the bottom of the piston, as shown in Figure 15.

6.4.9 Verify that the inner sleeve o-ring is in the lower groove, not in the upper groove, which has the vent hole.

6.4.10 Insert the piston into the sleeve.

6.4.11 Place the diaphragm in the valve body.

6.4.12 Slide the piston and sleeve assembly into the valve body, the piston faces away from the bottom of the body, as shown in Figure 15.

6.4.13 Place the flange o-ring into the flange groove, and position the outlet assembly onto the inlet section. Align the exhaust piping by hand tightening the four cap screws with lockwashers, and union nut.

6.4.14 Tighten the four hex head cap screws. After the screws are secure, tighten the exhaust piping union.

6.5 Exhaust Muffler, Figure 15

6.5.1 Separate the two halves of the muffler housing by removing the six screws, and pry the halves apart. Note that the screw holes in the housing are not the same size. The side of the housing with the hex recess has a smaller diameter than the one without the hex. The screw is inserted into the larger diameter hole, and grips the smaller diameter hole.

6.5.2 Remove the muffler element, rubber liner and screen from each housing half.

6.5.3 Inspect the inside of the muffler element for sediment that prevents air from passing through the porous element. Replace the elements if blocked.

6.5.4 Inspect the two sealing o-rings on the exhaust body, and replace them if worn or damaged.

6.5.5 Clean and inspect all parts that are to be reused, replace if worn. Reassemble the exhaust muffler in reverse order.

**6.6 Quantum Metering Assembly, Ref. Figure 16
Refer to Section 6.7 to service the actuator segment.**

NOTE: Service kits are available for the Quantum metering assembly and actuator segment. Keeping kit(s) on-hand will avoid unnecessary downtime. Replace all seals provided in the kit whenever the valve is opened.

If immediate service is required and a service kit is not readily available, take extreme care not to misplace or damage o-rings, gaskets, or other seals. Thoroughly clean all reusable parts.

6.6.1 Empty the machine of abrasive per Section 3.9. Turn off the compressed air supply. Lockout and tagout the air supply, and bleed the air supply line to the blast machine.

6.6.2 Remove the cleanout cover wing nuts and cleanout cover.

6.6.3 Remove the four socket head screws securing the metering housing, and remove the housing assembly.

6.6.4 The flanged upper body and actuator do not need to be removed from the blast machine to service the metering assembly. Thoroughly inspect both items for wear, and replace if worn.

6.6.5 Turn the metering shaft clockwise to remove the shaft from the metering screw.

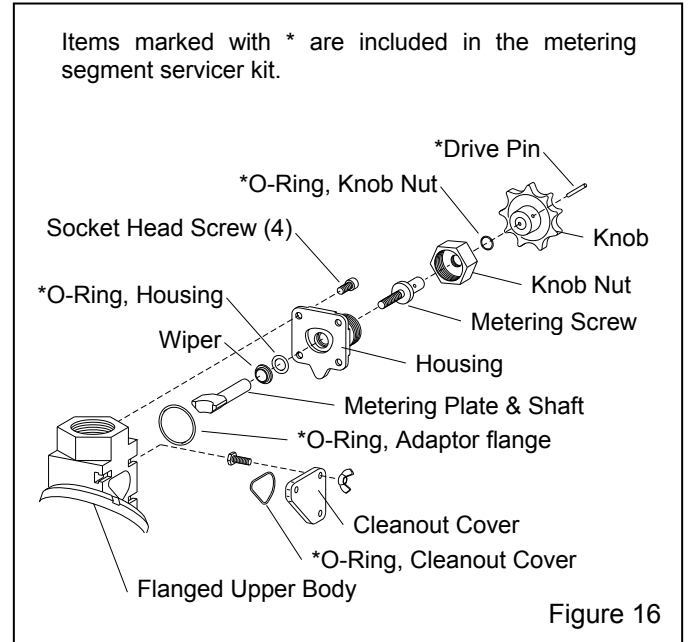

Figure 16

6.6.6 Loosen the knob nut, and pull the knob assembly from the housing.

6.6.7 Use a drive pin and hammer to force the roll pin from the knob, and remove the knob.

6.6.8 Remove the metering screw by pushing it out the front of the knob nut.

6.6.9 Inspect the metering screw for damage and any signs of abrasive ingress or metal filings.

6.6.10 Clean the threads on the metering screw, and test the condition of the threads by screwing it into the metering plate shaft. Replace the metering screw if there is any resistance, binding or metal filings.

6.6.11 Remove the o-ring from the knob nut, and remove the o-ring and wiper from the housing.

6.6.12 Thoroughly clean and inspect all parts that are to be reused. Replace all worn parts.

6.6.13 Place a new o-ring in the knob nut.

6.6.14 Place a new o-ring and wiper seal in the housing, as shown in Figure 16. The small side of the wiper seal faces away from the o-ring. A generous amount of silicone-based lubricant eases installation.

6.6.15 Insert the metering plate shaft through the housing bore, and wipe off any lubricant on the metering plate side of the bore.

6.6.16 Reassemble the metering screw, nut, knob, and drive pin. Note: applying a small amount of silicone-based lubricant on the unthreaded end of the metering shaft eases insertion through the nut o-ring.

6.6.17 Apply molybdenum disulfide or graphite-based anti-seize lubricant to the metering shaft and metering screw threads, and thread the shaft onto the screw.

6.6.18 Place a new o-ring in the groove on the face of the upper body.

6.6.19 Insert the metering plate (flat side up) through the upper body opening. Take care not to displace the internal o-ring.

6.6.20 Secure the metering housing finger tight before wrench tightening all screws.

6.6.21 Place a new o-ring on the cleanout cover, and securely attach the cover.

6.6.22 Service of the metering assembly is complete. Test the machine and piping for air leaks before returning to service.

6.7 Actuator Segment, Ref. Figures 17 and 18
Refer to Section 6.6 to service the metering assembly.

NOTE: Service kits are available for the Quantum metering assembly and actuator segment. Keeping kit(s) on-hand will avoid unnecessary downtime. Replace all seals provided in the kit whenever the valve is opened.

If immediate service is required and a service kit is not readily available, take extreme care not to misplace or damage o-rings, gaskets, or other seals. Thoroughly clean all reusable parts.

6.7.1 Empty all abrasive from the machine per Section 3.9. NOTE: If the metering assembly does not require service, abrasive flow may be stopped by closing the metering valve.

6.7.2 Turn off the compressed air supply. Lockout and tagout the air supply, and bleed the air supply line to the blast machine.

6.7.3 Remove the control line from the fitting on the actuator assembly.

6.7.4 Refer to Figure 17 and remove the screws securing the metering segment and outlet flange to the actuator assembly, and then remove the actuator

assembly. Both of the flange gaskets, plus the retaining ring, and o-ring will be loose as the actuator assembly is removed. Do not misplace them.

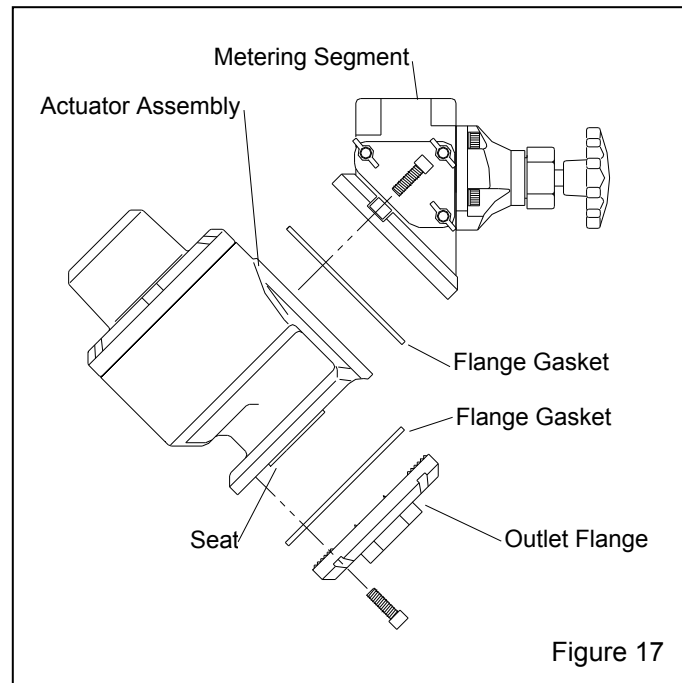

6.7.5 Refer to Figure 18 and unscrew the six socket head screws, and then remove the cylinder cover, spring and felt disc. Spring compression is removed when the cover is approximately 9/16" from the actuator body.

6.7.6 Use a hammer handle or similar object to push the plunger from the bottom (wear sleeve), forcing the plunger/piston assembly out the top of the body.

6.7.7 Pry the urethane seat from the bottom of the wear sleeve.

6.7.8 Remove the wear sleeve and roll pin from the body.

6.7.9 It is not necessary to separate the plunger from the piston unless either part is scored or worn. To separate the parts, hold the plunger in a vise with the vise jaws covered with copper or similar protection (if the plunger is damaged it does not matter if the vise jaws mar the plunger). Using a wrench placed on the flats of the piston stop, unscrew the stop.

6.7.10 Remove the wiper and o-ring from the actuator body.

- Inspect the urethane seat. Replace if worn or damaged.
- Inspect the body and outlet flange for wear. Replace if worn.

6.7.11 Clean all items and inspect for wear. Replace worn or damaged parts.

6.7.12 Replace the wiper and o-ring in the actuator body, the o-ring side of the wiper must face toward the bottom of the body, as shown in Figure 18.

6.7.13 Lubricate the o-ring and wiper in the actuator body, with a silicone-based lubricant.

6.7.14 If the plunger and piston were separated as noted in Section 6.7.9, apply removable thread sealant to the threads on the piston stop, and reassemble the parts using a new o-ring.

6.7.15 Install the plunger and piston assembly into the actuator body. Tuck in the lip of the piston cup while applying pressure to the piston, to make sure the leading lip on the piston does not curl.

6.7.16 Place the roll pin and wear sleeve in the actuator body. The sleeve is correctly positioned when the alignment slot in the sleeve fits the roll pin in the body.

6.7.18 Place the retaining ring o-ring into the groove on the bottom of the retaining ring. Place the retaining ring (o-ring down) on the outlet flange gasket, and align it with the opening.

6.7.19 Assemble the actuator assembly onto the upper body and outlet flange. Note: The upper body is secured with three screws, and the outlet flange is secured with four screws. The gaskets are the same for both parts. Align the gaskets so the mounting holes match the pattern in the flange. First hand-tighten the outlet flange screws (this ensures that the retaining ring and o-ring do not shift during the remainder of the assembly). Hand-tighten the upper body flange screws before tightening all screws.

6.7.20 Install the felt disc, spring, and cylinder cover, and tighten the screws to secure.

6.7.21 Connect the control line to the compatible fitting on the actuator assembly, and test the operation before putting the valve in service.

6.8 Abrasive Trap

NOTE: A service kit is available for the abrasive trap. To avoid unscheduled downtime, keep a kit on-hand.

6.8.1 All service on the abrasive trap must be done with the compressed air off and the air supply locked-out and tagged-out.

6.8.2 Clean the abrasive trap screen and trap at least twice a day. **NOTE:** Failure to clean the abrasive trap on a regular basis is a major cause of system malfunction.

6.8.3 To check the abrasive trap screen, loosen the top thumbscrew, and swing the lock bar off the cap, and remove the cap.

6.8.4 Remove the screen and inspect it for wear and blockage. Replace it when it is clogged or worn. Keep spare screens on hand. Do not install the screen in the trap until the bottom section of the trap is cleaned per the following instructions.

6.8.5 To clean the bottom section of the trap, loosen the bottom thumbscrew, and swing the lock bar off the bottom cap, and remove the cap.

6.8.6 Empty all abrasive from the bottom and top sections.

6.8.7 Install the screen in the top section. The small end of the screen must face up.

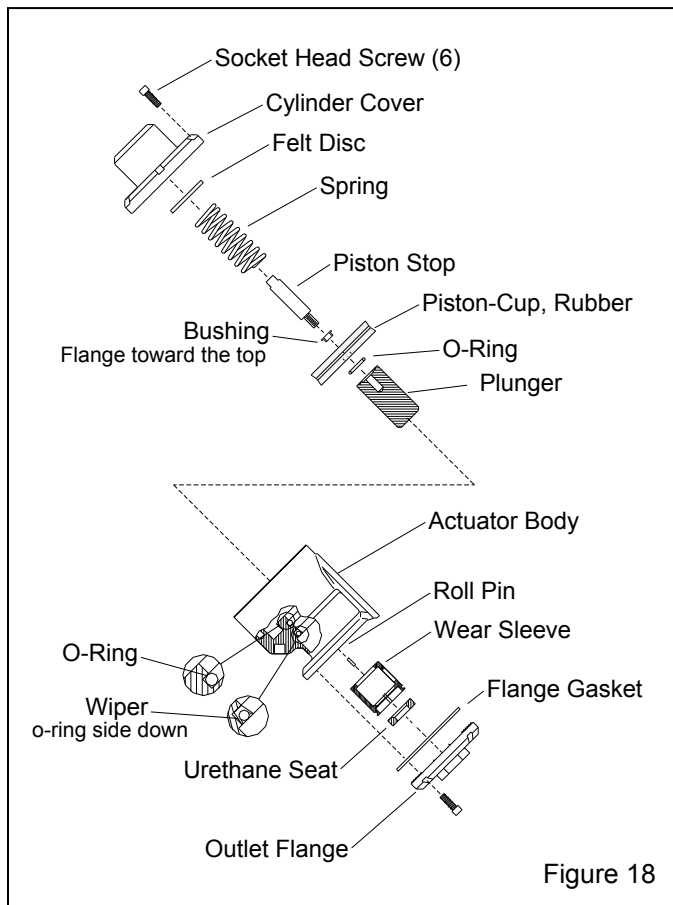

6.7.17 Place the urethane seat into the wear sleeve, with the beveled side facing toward the sleeve.

6.8.8 Reassemble the top and bottom caps. Make sure the o-rings are in place on the caps before assembly, and the screen gasket is in place in the top cap.

6.9 RLX Control Handle

NOTE: A service kit is available for the RLX Control Handle. To avoid unscheduled downtime, a kit should be kept on-hand.

6.9.1 Spring replacement

6.9.1.1 To replace the lever lock spring, follow the instructions in Section 6.9.2. To replace the handle lever spring, follow the instructions in Section 6.9.3.

6.9.2 Lever lock replacement, Figure 19

6.9.2.1 Remove the lock nut from the shoulder screw. Before removing the screw, note the positions of the spacers and spring, as shown in Figure 19. The bent end of the spring is toward the inside, forcing the lever lock up. The straight end is toward the outside, facing down and against the tab.

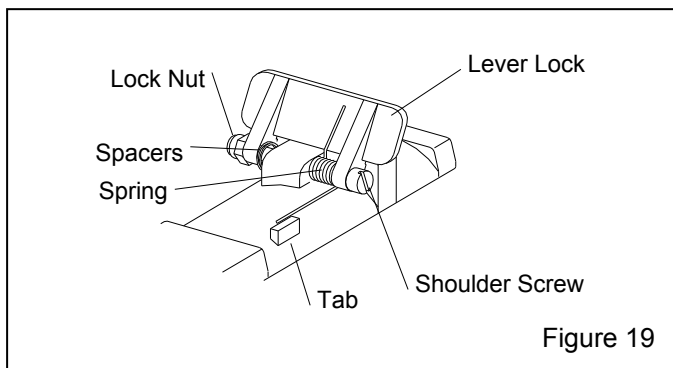

6.9.2.2 Install a new lever lock and spring, and reassemble in reverse order.

6.9.2.3 Make sure the lever lock moves freely, raises to full up position, and that the handle lever does not engage unless the lever lock is pulled down.

6.9.3 Handle lever replacement, Figure 20

6.9.3.1 Remove the lock nut from the shoulder screw. Before removing the screw, note the positions of the spacers and spring as shown in Figure 20. The bent end of the spring is against the handle lever, facing up. The straight end is against the body, facing down.

6.9.3.2 Install a new handle lever and spring, and reassemble in reverse order.

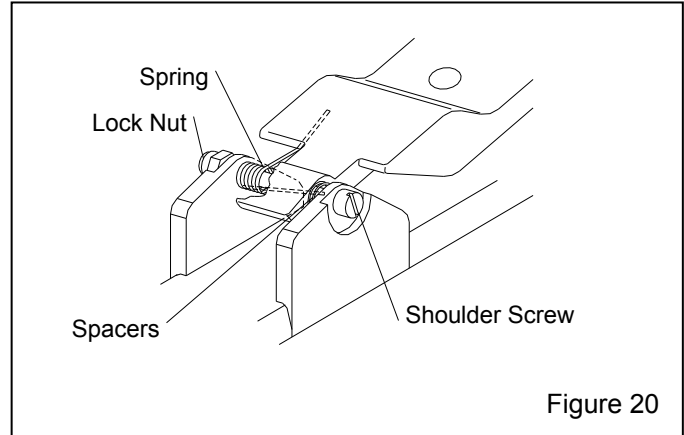

Figure 20

6.9.3.3 Make sure the handle lever moves freely, raises to full up position, and does not engage unless the lever lock is pulled down.

6.9.4 Rubber button replacement

6.9.4.1 Remove the old rubber button.

6.9.4.2 Install the new button, stem first, by pushing it from the bottom side of the handle lever. Pull the stem to seat the button.

6.9.4.3 Trim the button stem flush with the top of the handle lever.

6.9.5 Gasket replacement

6.9.5.1 Remove the handle lever per Section 6.9.3.

6.9.5.2 Remove the six screws holding the pneumatic adaptor to the body.

6.9.5.3 Install a new gasket.

6.9.5.4 Place the pneumatic adaptor on the gasket and hand tighten all screws before tightening them in sequence to uniformly compress the gasket.

6.9.5.5 Reassemble the handle lever, making sure the spacer washers and spring are in place.

6.9.5.6 Make sure the handle lever moves freely, raises to full up position, and does not engage unless the lever lock is pulled down.

6.10 Replacing the Pop-Up Valve, Figure 21

6.10.1 All service on the pop-up valve must be done with the compressed air off and the air supply locked-out and tagged-out.

6.10.2 To gain access to the pop-up valve, remove the inspection door assembly.

6.10.3 Using a small pipe wrench, unscrew the pop-up valve guide by turning it counterclockwise. Remove the pop-up valve and guide from the machine.

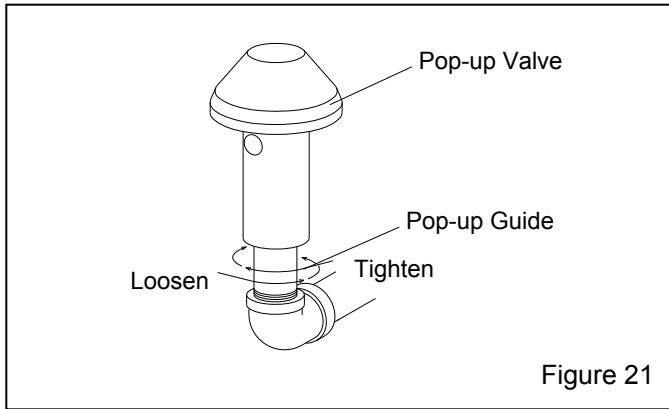

Figure 21

6.10.4 While the pop-up valve is out, check alignment as follows: Screw a 1-1/4" nipple, which is at least 12" long, into the elbow in place of the pop-up guide. Check the alignment through the pop-up filling port. The nipple should be close to the center of the port. If it is not, adjust the horizontal pipe. A misaligned pop-up valve could result in early valve failure, or abrasive leakage when the machine is pressurized or depressurized.

6.10.5 Slide the new pop-up valve over the guide, and then screw the valve guide (with the pop-up valve on it) into position inside the machine. Tighten the guide, it should be wrench-snug, but not wrench-tight. Over-tightening the guide will make it difficult to remove the next time the pop-up valve needs replacement.

6.10.6 Refer to Figure 22 to check the pop-up height. If the pop-up sits too low, misalignment could occur when the pop-up comes up against the seal. If the pop-up sits too high, it will take longer for abrasive to flow through the opening when filling. Adjust the height by replacing the guide with one that is longer or shorter.

6.10.7 Put a new gasket on the inspection door assembly before bolting the door onto the machine.

6.11 Replacing the Pop-Up Seal

6.11.1 All service on the blast machine must be done with the compressed air off and the air supply locked-out and tagged-out.

6.11.2 Remove the old seal using fingers, screwdriver, or similar object, to work the seal out of the retaining groove.

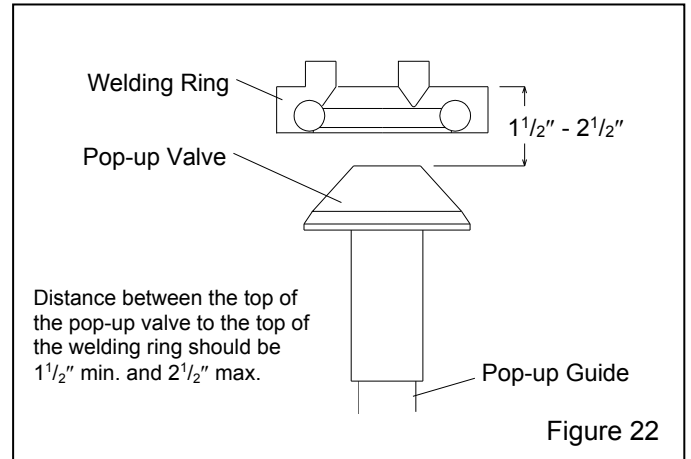

Figure 22

6.11.3 Push the new seal all the way through the port and then fit it into the retaining groove. For the last few inches, pull up on the seal and allow it to pop into position.

6.12 Remove and Install Reusable Control Hose Ends, Refer to Figure 23

NOTE: Control hoses may be shortened and cut to length as follows:

1. Remove the hose end by placing the sleeve in a vise or use a backup wrench on the sleeve to prevent it from turning. Unscrew the insert by turning it counterclockwise.
2. Turn sleeve clockwise to remove from the hose.
3. Cut hose to length.
4. Turn sleeve counterclockwise to install on hose. Do not over-tighten the sleeve, stop tightening as soon as the hose bottoms-out against the sleeve's internal shoulder. Over-tightening will cause the hose to curl inward and could cause blockage.
5. Push end of insert into sleeve, and turn clockwise to tighten until the insert hex is against the sleeve.

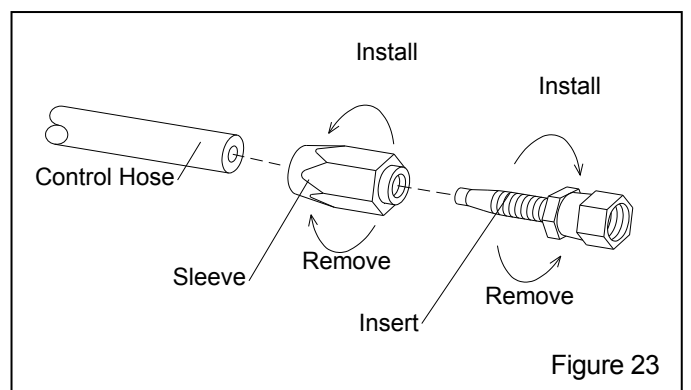

Figure 23

7.0 TROUBLESHOOTING

NOTE: This section only identifies conditions and problems in the blast machine and remote control system. Always refer to the appropriate section of this manual, or manuals for accessory equipment when troubleshooting and before servicing the equipment.

WARNING

To avoid serious injury, observe the following when troubleshooting the machine and remote controls.

- Turn off the compressed air and Lock-out (Be certain the air supply is off and that it cannot be started while work is in process) and tag-out (Be certain the air supply is clearly marked to prevent re-starting while work is in process) the compressed air supply.
- When checking the controls requires air, always enlist the aid of another person to operate the control handle while holding the nozzle securely and pointing it in a safe direction.
- Never strap the remote control handle lever down in the operating position.

7.1 Neither abrasive nor air exits the nozzle while the machine is under pressure

7.1.1 Depressurize the blast machine. After the pop-up valve has dropped, remove the nozzle, and check it for obstruction.

7.1.2 Make sure that both the abrasive metering valve and choke valve are open.

7.2 Air only (no abrasive) exits the nozzle

7.2.1 Abrasive metering valve may be closed or needs adjustment. See Section 4.1.

7.2.2 Make sure the ACS is in the blast position (toggle pointing away from nozzle).

7.2.3 Blast machine may be empty.

7.2.4 Abrasive may be damp. See Section 6.1 to clear damp abrasive.

7.2.5 Check the abrasive metering valve for obstructions. See Section 6.2.

7.2.6 The abrasive metering valve actuator may require service. See Section 6.7.

7.2.7 Check for air leaks in the single-line hose between the ACS and metering valve.

7.3 Heavy abrasive flow

7.3.1 Make sure the choke valve is fully open. The valve is open when the handle position is aligned with the piping.

7.3.2 Abrasive metering valve may be open too far. See Section 4.1.

7.3.3 Check the abrasive metering valve for wear. Look for wear on the abrasive valve metering plate.

7.4 Abrasive surging

7.4.1 A moderate amount of abrasive surge is normal at start-up. Should the flow of abrasive continue to surge, reduce the amount of abrasive in the air stream by adjusting the metering valve. See Section 4.1.

7.4.2 Check the abrasive trap and exhaust muffler for blockage. Slow depressurization will load the blast hose with abrasive, and cause surging at start-up. See 7.7.

7.4.3 Make sure the choke valve is fully open. The valve is open when the handle is aligned with the piping.

7.5 Intermittent abrasive flow

7.5.1 Moisture in the blast machine or in the air supply. Drain moisture from the compressor's receiver tank, and the blast machine's air filter. If problem with moisture persists, an after-cooler or air dryer may be required.

7.5.2 Abrasive may be worn from recycling. Replace abrasive.

7.6 Blast machine does not pressurize

7.6.1 Make sure the compressor is on and all air supply valves to the machine are open.

7.6.2 Make sure the safety petcock is closed.

7.6.3 Check the rubber button on the control handle for wear or damage, and make sure the opening on the control handle seals when the handle is pressed.

7.6.4 Check for air escaping through the opening under the control handle lever. If no air is escaping, the orifice on the inlet valve (Item 13, Figure 29) is blocked, or the line from the orifice to the control handle is blocked and must be cleared.

7.6.5 Press the control handle lever. Feel for and listen for air leaks on the handle. No air should escape when the handle lever is pressed. If there is a leak, it must be located and repaired.

7.6.6 Check control lines and fittings for leaks.

7.6.7 Open the safety petcock, and press the control handle lever; air should come out of the petcock. If it does not, check the following:

- Opening on the control handle is not sealed off.
- Air leaks in control handle.
- Line from the control handle to the upper fitting on the inlet valve is blocked.

If air comes out the petcock, then the inlet section of the Millennium valve is not functioning. Turn off the compressed air and service the valve per Section 6.3.

7.6.8 Close the safety petcock, and press the control handle lever. Verify that no air escapes through vent holes on the cylinder body of the inlet valve body. Air escaping from vent holes indicate worn seals in the inlet valve. See Section 6.3.

7.6.9 Inlet valve malfunctioning. Inspect internal parts for wear, and lubrication. See Section 6.3.

7.6.10 Insufficient-size air supply hose or reduced-size fittings between the compressor and blast machine. Refer to Section 2.3.

7.6.11 Dirty filter in optional air filter. Check filter element.

7.6.12 Pop-up valve stuck, or internal piping worn or out of alignment. Inspect internal piping.

7.7 Blast machine does not depressurize or depressurizes too slowly

7.7.1 Abrasive trap screen blocked, or abrasive trap needs cleaning. Clean the trap at least twice daily.

7.7.2 Exhaust muffler blocked. See Section 6.5.

7.7.3 Check the pneumatic adaptor gasket on the control handle for swelling, which restricts air flow through the handle.

7.7.4 Check for blockage in the control hose.

7.7.5 Check the fitting on the inlet valve (shown in Figure 29, Item 13). It must have a 1/16" orifice.

7.7.6 Remote control valves malfunctioning. Inspect the inlet and outlet valves per Section 6.3 and 6.4.

7.8 Outlet Valve Does Not Seal

7.8.1 Outlet valve requires service. See Section 6.4.

7.9 RLX control handle lever fails to return to the non-blast position (up) when released

7.9.1 Check the handle lever for damage that may cause binding against the body. Replace as necessary.

7.9.2 Check the spring for damage or fatigue. Replace as necessary.

7.10 Lever lock fails to pop up when the handle is released

7.10.1 Check the lever lock for damage, or build up of debris or abrasive. Replace as necessary.

7.10.2 Check the lever lock return spring for damage or fatigue. Replace as necessary.

8.0 ACCESSORIES AND REPLACEMENT PARTS

8.1 Accessories

- (-) Cover, steel for
4 cu. ft., 20" diameter blast machine..... 20358
6 cu. ft., 24" diameter blast machine..... 02336
- (-) Cover, poly bag with Clemco logo for
4 and 6 cu. ft. machines, large 15143
- (-) Screen, recessed type, for
4 cu. ft., 20" diameter blast machine..... 20357
6 cu. ft., 24" diameter blast machine..... 03100

8.2 Hose Safety Accessories, Figure 24

Item	Description	Stock No.
1.	Safety cable for 1-1/2" to 3" OD hose	15013
	for 1-1/2" to 4" OD hose	27405
2.	Lock pin, coupling (package of 25)	11203

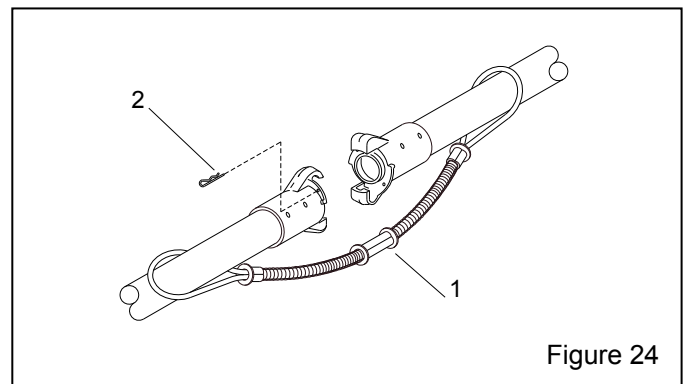

Figure 24

8.3 Blast Machine, Figure 25

Item	Description	Stock No.
1.	Ball valve, 1-1/4" with handle	02397
2.	Handle, 1-1/4" ball valve	22532
3.	Pusher line assembly, 1-1/4" x 31"	23675
4.	Compression coupling, 1-1/4"	01857
5.	Gasket, compression coupling, 1-1/4"	01886
6.	Coupling, 1-1/4" CF for 4 cu. ft. w/12" nipple	27720
	6 cu. ft. w/16.5" nipple	24197
7.	Metering valve, Auto-Quantum without wye and fittings	22760
	with 1-1/4-NPT wye and fittings	24447
8.	Wheel, primary, for 4 cu. ft., 12" dia. x 300	20426
	6 cu. ft., 16" dia. x 400	20427
9.	Inspection door assembly, 6" x 8"	02377
10.	Gasket, inspection door, 6" x 8"	02369
11.	Seal, pop-up valve	02325
12.	Pop-up valve, 4", with external sleeve	03699
13.*	Air filter, optional, 1-1/2" manual drain	22363
14.	Millennium inlet/outlet valve	21336
15.*	Gasket, CQG, package of 10	00850
16.	Wye, standard 1-1/4"	01818
17.	Internal pop-up guide, 1-1/4" x 6" toe	01753
18.	Leg cap (manual tube cover)	21517
19.	Axle, 1" dia x 30.5"	02402
20.	Washer, 1" thrust	03825
21.	Retaining ring, 1"	03824

22.	Abrasive trap	02011
23.	Wheel, secondary, 10" x 2.75	20349
24.	CPF-20 Air filter, optional	03578
25.	Cartridge, CPF filter	03547
26.*	Coupling, nylon, for 4 cu. ft., CQPS-1	21088
	6 cu. ft., CQPS-2	08413
27.*	Nozzle holder, nylon, for 4 cu. ft., NHP-1	04106
	6 cu. ft., NHP-2	04127
28.*	Hose, Supa, for 4 cu. ft., 1" ID x 50 ft.	23104
	6 cu. ft., 1-1/4" ID x 50 ft.	23106
29.*	Nozzle, for 4 cu. ft., TMP-5	23521
	6 cu. ft., TXP-6	23525
30.*	Washer, nozzle, for 4 cu. ft., NW-25, pack of 10	91024
	6 cu. ft., NW-32, pack of 10	91026
31.*	Gasket, hose coupling, package of 10 CQGP-2, for 4 cu. ft. (for Item 26)	08852
	CQGP-3, for 6 cu. ft. (for Item 26)	08853
32.	Adaptor, 1-1/4" NPT x JIC	22529
33.**	Hose, 5-ft respirator extension, coupled.	24510
34.**	Union, 3/8 Respirator hose	01020

* Models shown are supplied with original blast machine systems.

** Supplied with factory-installed CPF-20 Air Filter option only.

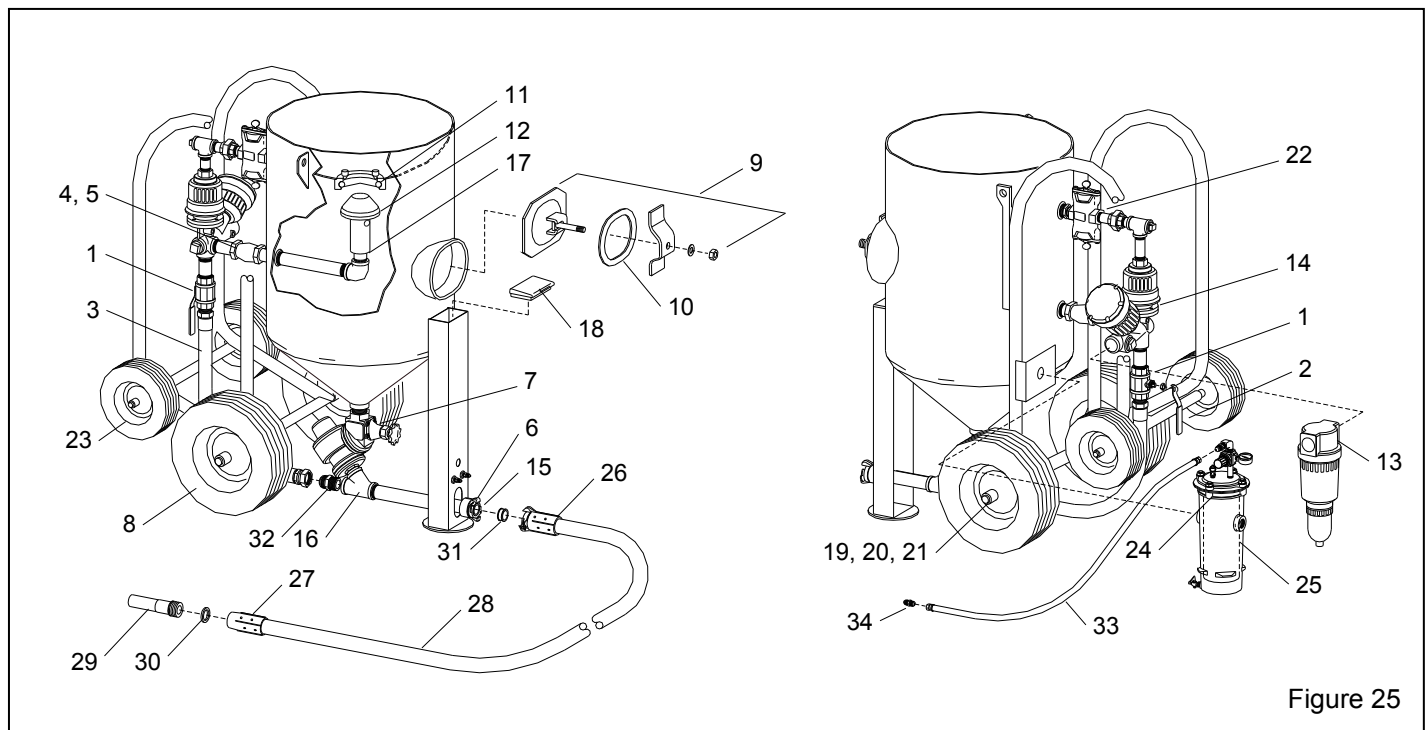

Figure 25

8.4 Remote Control System Parts, Figure 26

Item	Description	Stock No.
1.	Millennium inlet/outlet valve	21336
2.	Metering valve, Auto-Quantum without wye and fittings	22760
	with 1-1/4-NPT wye and fittings	24447
3.	RLX Control handle w/ ACS	07625
4.	Hose, 4' twinline cpld.	21619
5.	Hose, 50' twinline cpld.	01951
6.	Hose, 50' 3/16" single-line	03087
7.	Hose, 3/16" x 18"	02454
8.	Fitting, 1/4" NPT bulkhead	05605
9.	Adaptor, 1/4" NPT	02494
10.	Adaptor, 1/8" NPT elbow	02827
11.	Tie, nylon	02195

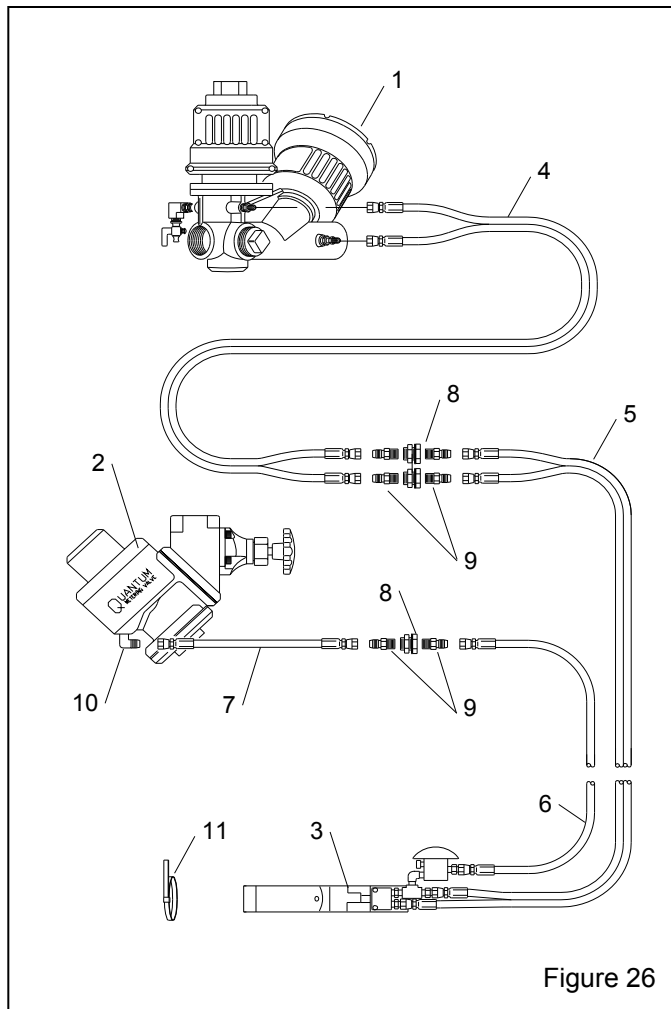

Figure 26

8.5 Quantum Metering Valve Actuator, Figure 27

Item	Description	Stock No.
(-)	Auto-Quantum metering valve without wye and fittings	22760
	with 1-1/4-NPT wye and fittings	24447
*	Service kit, Quantum actuator (Fig. 27a)...	24446
1.	Cover, cylinder	21317
2.	Stop, piston	21323
3.	Piston-cup w/bushing	21329
4.	Valve body	21349
5.	Plunger, grit valve	21326
6.	Wear sleeve, grit valve	21342
7.	Seat, urethane	21344
8.	Flange, outlet w/retaining ridge	21319
9.	Screw, 5/16-NC x 1-3/4" socket head	21321
10.	Screw, 5/16-NC x 1" socket head	21318
11.	Spring	20600
12.	Adaptor, 1/4" NPT elbow	02513
13.	Petcock, 1/4" NPT	01993
14.	Nipple, 1-1/2" x close Schedule 80	01791
15.	Nipple, 1-1/4" x 2"	01718
16.	Wye, 1-1/4"	01818
17.	Wye, 1-1/2" NPT	01819
18.	Bushing, 1-1/2 NPT x 1-1/4 NPT	01805
19.	Nipple, 1-1/4 x close HD	01854
20.	Metering assembly	See Section 8.6

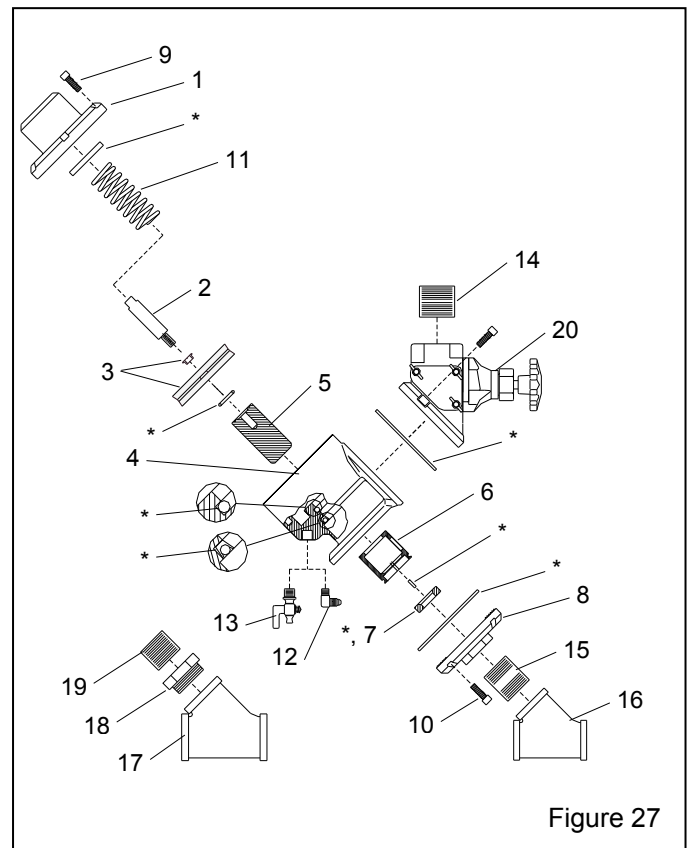
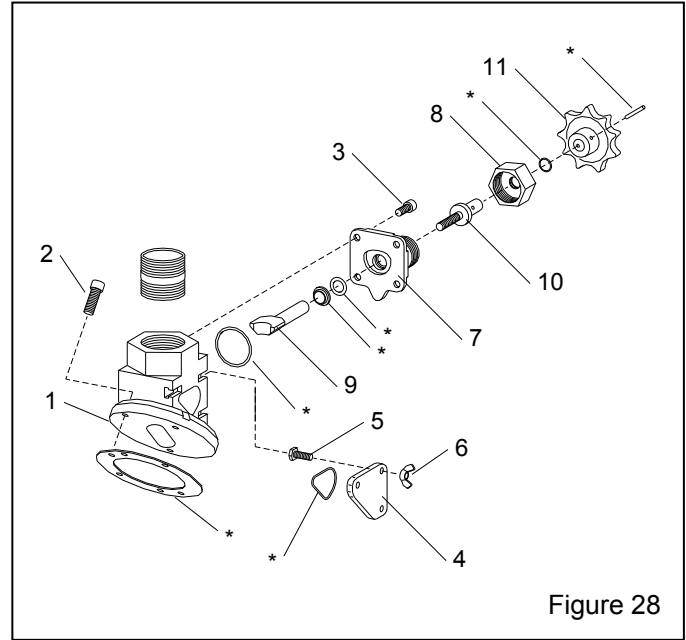
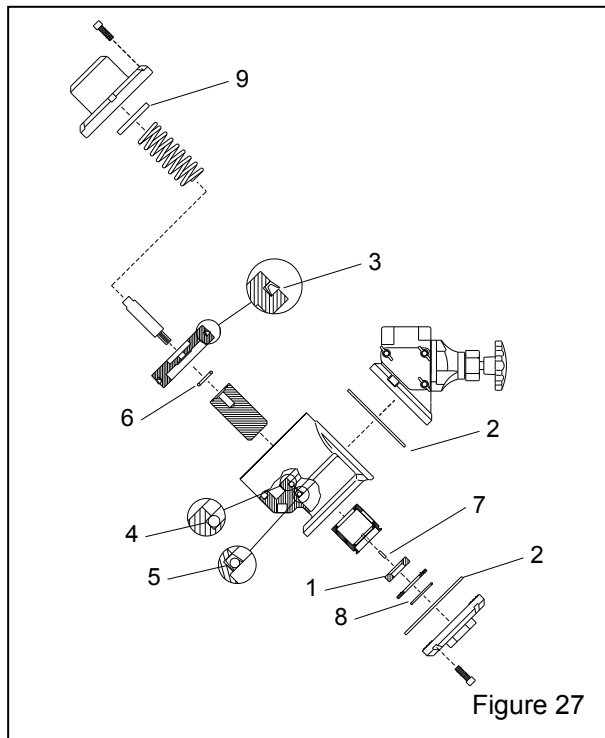

Figure 27

**24446 SERVICE KIT
QUANTUM ACTUATOR**

Item	Qty	Description
1.	1	Seat, urethane
2.	2	Gasket, flange
3.	1	U-seal, 3-1/2" ID (For old style alum. piston)
4.	1	O-ring, 1-1/2" ID x 3/16" nom.
5.	1	Wiper, plunger
6.	1	O-ring, 31/64" ID
7.	1	Roll pin, 1/8" x 1/2"
8.	1	O-ring, 1-1/2" ID x 3/32" nom.
9.	1	Felt disc

Item 8 is not used with current 21319 outlet flange. Used with early 22077 flange requiring a separate 22429 retaining ring.



**22854 SERVICE KIT
QUANTUM METERING SECTION**

Item	Qty	Description
1.	1	Flange gasket
2.	1	Wiper seal
3.	1	O-ring, 3/4" OD nominal
4.	1	O-ring, 5/8" OD nominal
5.	2	O-ring 1-1/2" ID nominal
6.	1	Roll Pin

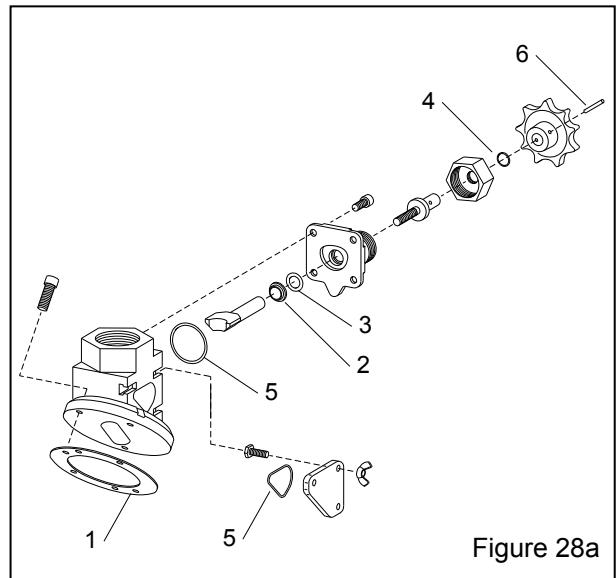

8.6 Quantum Metering Segment, Figure 28

Item	Description	Stock No.
*	Service kit, metering section (Fig. 28a).....	22854
1.	Upper body, flanged	21314
2.	Screw, 3/8-NC x 1" socket head	22655
3.	Screw, 5/16-NC x 3/4" socket head	22767
4.	Cover, cleanout	22620
5.	Screw, 1/4-NC x 3/4" hex head cap	03052
6.	Nut, 1/4-NC wing	03113
7.	Housing, knob	22761
8.	Nut, knob-housing	22762
9.	Metering plate and shaft	22763
10.	Metering screw	22764
11.	Knob, adjustment	22766

8.7 Millennium valve service kit 22899
Includes the following four service kits shown in Sections 8.7 and 8.8: 22856, 22898, 22857, and 22868

8.8 Millennium Valve, Inlet Segment, Figure 29

Item Description Stock No.

- * Service kit, Millennium Inlet seals (Fig. 29a) 22856
- ** Service kit, Millennium plunger tip (Fig. 29b).. 22898
- 1. Plunger 22600
- 2. Dual piston 22602
- 3. Spring, 4" long 22604
- 4. Screw, socket, w/internal threads 22650
- 5. Sleeve, cylinder 22603
- 6. Screw, 5/16-NC x 1-1/4", socket head 22611
- 7. Body, inlet valve 21338
- 8. Cap, cylinder 21339
- 9. Plug, 1-1/2" NPT 02477
- 10. Nipple, 1/4" NPT hex 02808
- 11. Elbow, 1/4" NPT 90° female 06373
- 12. Petcock, 1/4" NPT 01993
- 13. Adaptor, 1/8" NPT w/1/16" orifice 01945
- 14. Bushing, 1/4" x 1/8" brass 02010
- 15. Adaptor, 1/4" NPT 02494
- 16. Plug, 1-1/4" NPT 01762

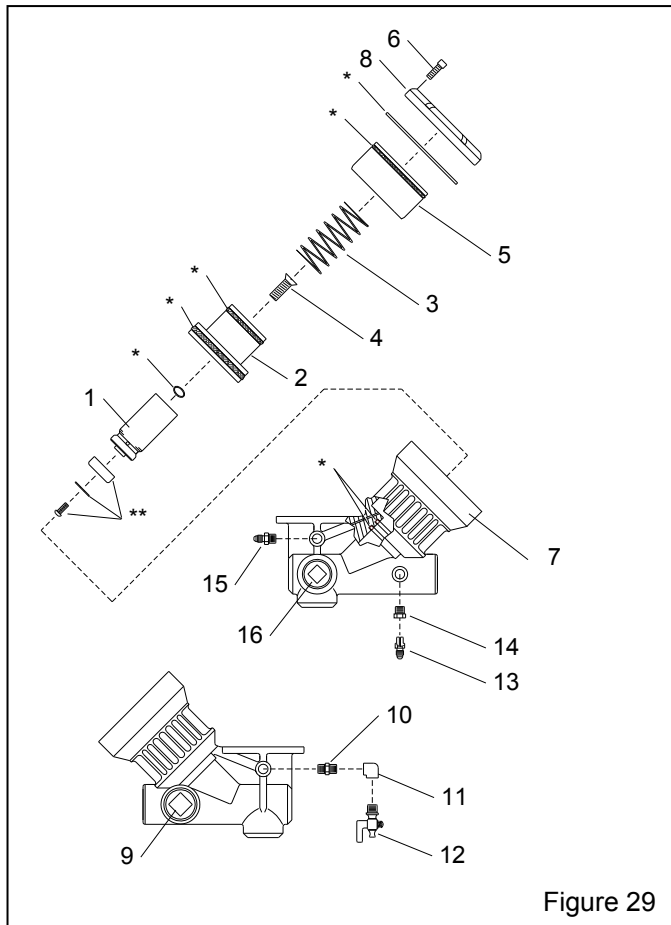

**22856 SERVICE KIT
MILLENNIUM INLET SEGMENT SEALS**

Item	Qty	Description
1.	2	O-ring, 2-1/8" OD, nominal
2.	1	U-seal, dual piston lower, 3-1/2" ID
3.	1	U-seal, dual piston upper, 2-3/8" ID
4.	1	O-ring, 4-1/8" OD, nominal
5.	1	O-ring, 31/64" ID, nominal
6.	1	Gasket, cylinder cap

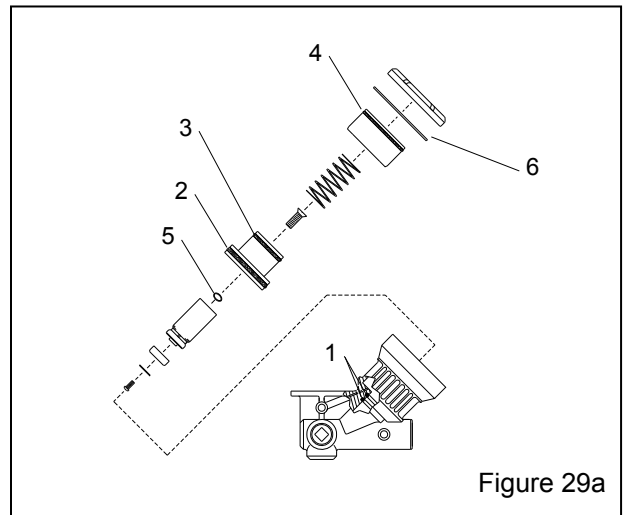

**22898 SERVICE KIT
MILLENNIUM PLUNGER TIP**

Item	Qty	Description
1.	1	Screw, 5/16-NC button head
2.	1	Washer, plunger tip
3.	1	Tip, replaceable plunger

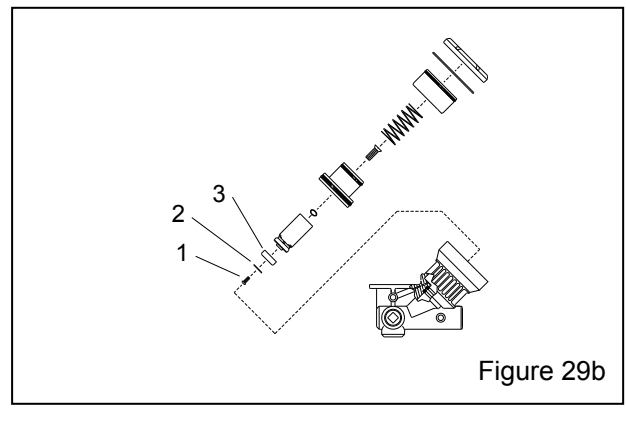

8.9 Millennium Valve Outlet Segment, Figure 30

Item	Description	Stock No.
(-)	Outlet valve & muffler assembly21731 Includes everything pictured in Fig. 30	
*	Service kit, outlet segment (Fig. 30a)22857	
**	Service kit, muffler (Fig. 30b)22868	
1.	Sleeve, inner22612	
2.	Piston22613	
3.	Housing, muffler, 2 required21346	
4.	Valve body, exhaust21345	

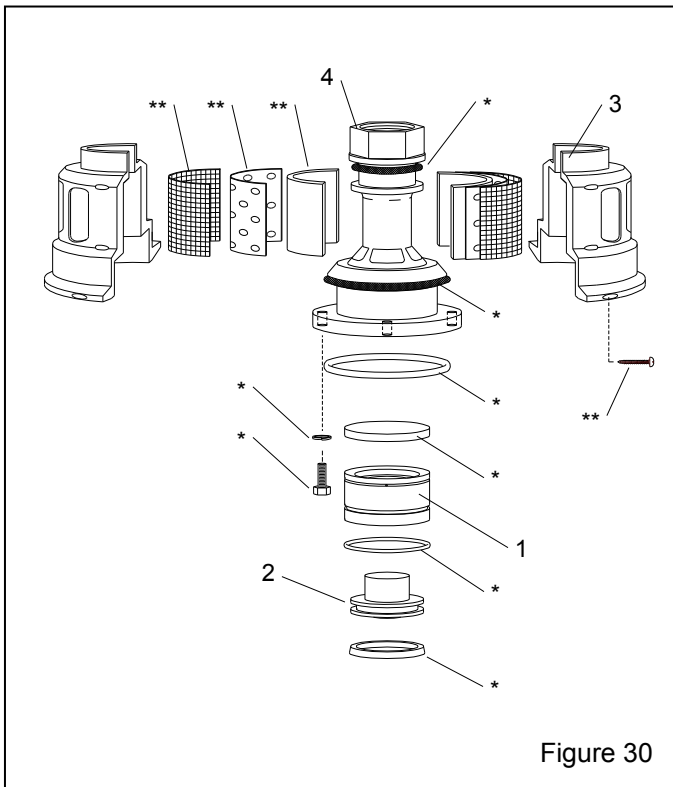

Figure 30

**22857 SERVICE KIT
MILLENNIUM OUTLET SEGMENT**

Item	Qty	Description
1.	1	O-ring, 1-5/8" ID nominal
2.	1	Diaphragm
3.	1	U-seal, piston
4.	2	O-ring, 3" ID nominal
5.	1	O-ring, 2-7/16" ID nominal
6.	4	Cap screw, 5/16-NC x 1"
7.	4	Lock-washer, 5/16"

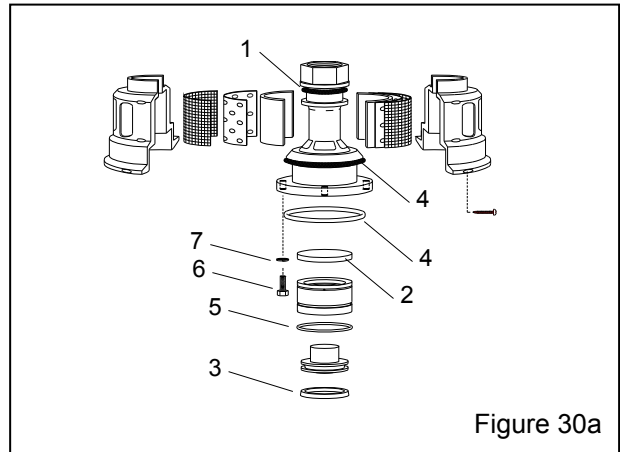

Figure 30a

**22868 SERVICE KIT
MILLENNIUM OUTLET MUFFLER**

Refer to owner's manual for service instruction.

Item	Qty	Description
1.	2	Muffler element
2.	2	Liner, perforated rubber
3.	2	Screen
4.	6	Screw, 12 x 1"

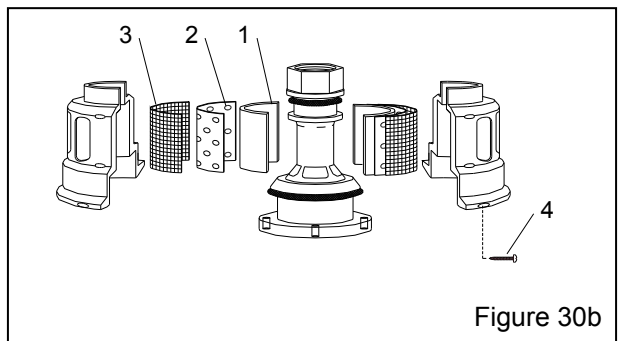

Figure 30b

8.10 RLX Pneumatic Control Handle with ACS, Figure 31

Note: Refer to Section 8.11 for RLX replacement parts

Item	Description	Stock No.
(-)	RLX Control Handle Assembly w/ ACS	07625
1.	RLX Control Handle (Standard)	10565
2.	Switch assembly, ACS pneumatic	07654
3.	Elbow, 1/8" NPT male	03085
4.	Tee, 1/8" NPT brass	02171
5.	Adaptor, 1/8" NPT	01940
6.	Guard, ACS pneumatic switch	07655
7.	Breather muffler, 1/8" NPT	07657
8.	Switch only, ACS	07658
9.	Connector, 1/8" NPT brass	01962

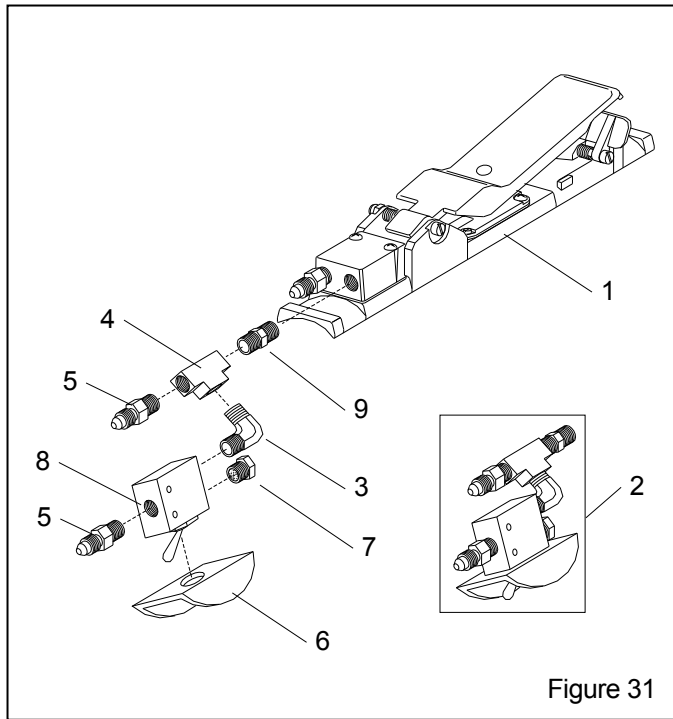

Figure 31

8.11 RLX Pneumatic Control Handle, Figure 32

Item	Description	Stock No.
(-)	RLX Pneumatic Control Handle Assembly ...	10565
*	Service kit, Pneumatic RLX (Fig. 32a)	22859
1.	Handle lever	10573
2.	Body	10568
3.	Pneumatic adaptor	10562
4.	Adaptor, 1/8" NPT (2 required)	01940
5.	Tie, nylon wire	02195

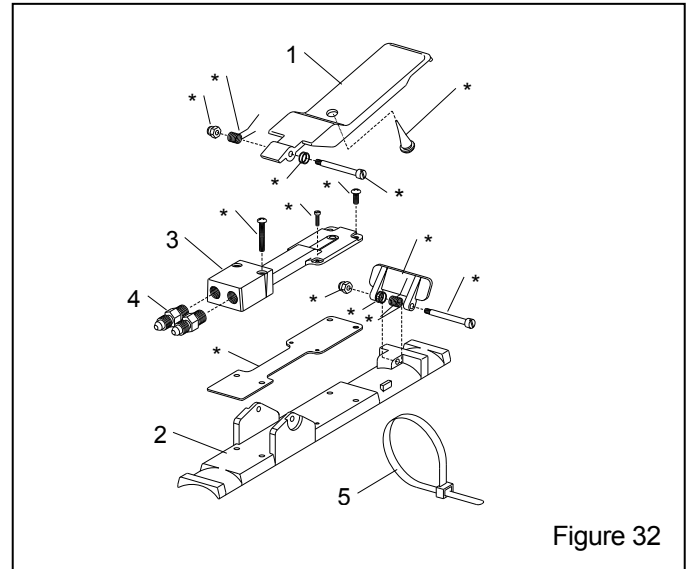

Figure 32

**22859 SERVICE KIT
RLX PNEUMATIC CONTROL HANDLE**

Item	Qty	Description
1.	1	Lever lock
2.	2	Spring
3.	2	Nut, 8-32 lock, ss
4.	4	Spacer washer, stainless steel
5.	2	Screw, 3/16" x 1-1/4" shoulder
6.	2	Screw, 8-32 x 1"
7.	2	Screw, 4-40 x 3/8"
8.	3	Rubber button
9.	1	Gasket, pneumatic adaptor
10.	2	Screw, 8-32 x 3/8"

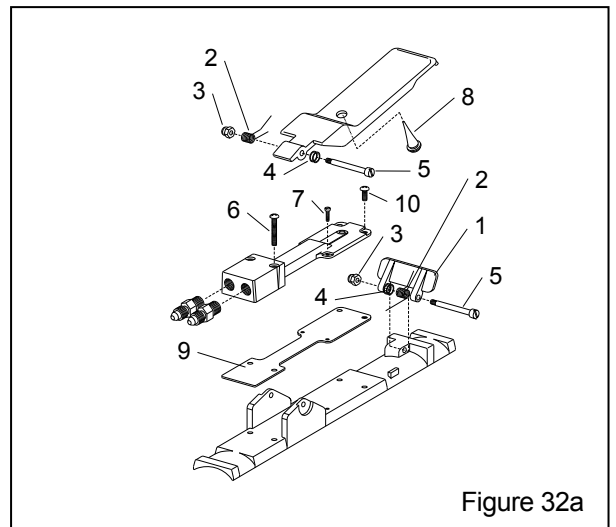
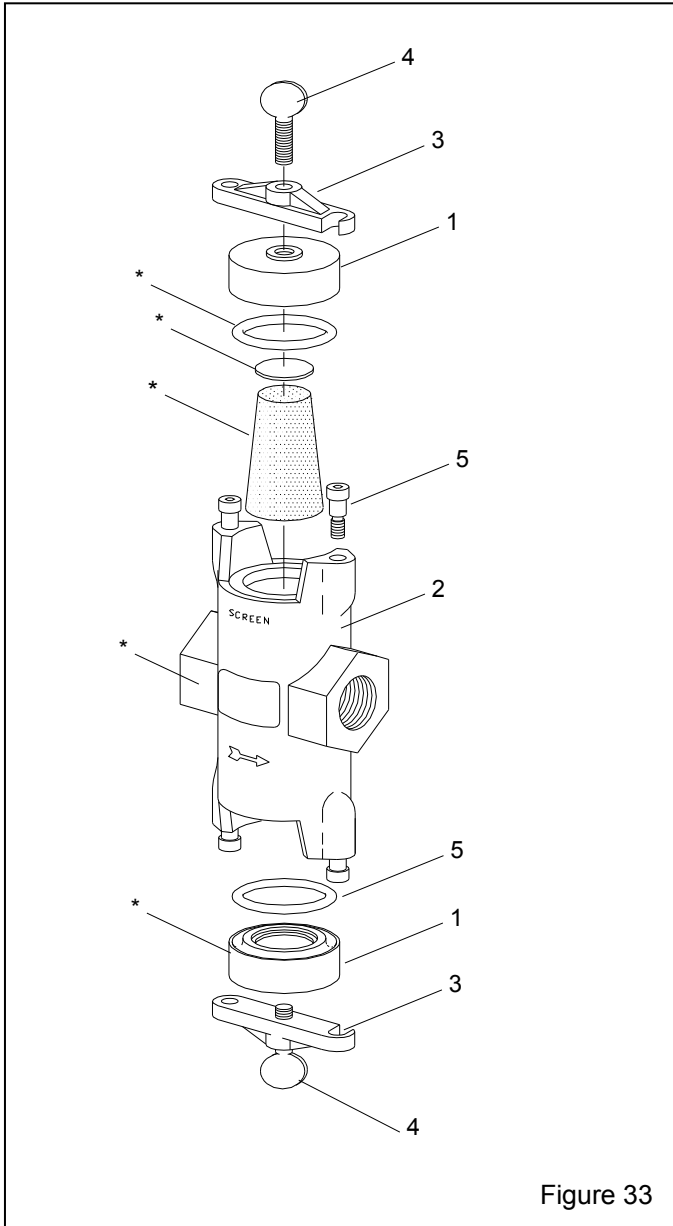

Figure 32a

8.12 Abrasive Trap, Figure 33

Item	Description	Stock No.
(-)	Abrasive trap	02011
*	Service kit, abrasive trap (Fig. 33a)	01925
1.	Cap	02014
2.	Body	02015
3.	Lock bar	02016
4.	Screw, 3/8-NC x 1" thumb	03289
5.	Shoulder screw, 3/8" x 3/8"	03291



01925 SERVICE KIT
ABRASIVE TRAP

Item	Qty	Description
1.	3	Screen
2.	2	O-Ring
3.	1	Gasket, screen, 1/8" thick
4.	1	Decal, "clean screen"

