

SUPERSONIC LIFTKLEEN™



PLC
CONTROLS
CYCLE, WASH
& SPARGER
SPRAY TIMES

24/7
HEATER &
SKIMMER
TIMERS



TUS3725SL

6000
WATTS OF
PEAK
POWER



TUS3725SL
HAS THREE
ULTRASONIC
GENERATORS

IMMERSION CLEANING COUPLED WITH POWERFUL ULTRASONICS

The TUS3725SL-model comes equipped with features to achieve ultimate parts cleaning levels. It is built to withstand rugged use in applications like engine rebuilding, performance racing, maintenance and manufacturing, but gentle enough to be used in the most delicate of cleaning applications.

Units available without Ultrasonics under part number TS3725SL-J, which includes all other great features for applications not requiring Ultrasonics. Consult Graymills for details.

Authorized Distributor:



Fortune Metal Finishing Corp.
116 Gould Street
Needham Heights, MA 02494
866.449.4160
sales@fortunemetal.com

Ultimate Performance

Full PLC control for ultrasonics, platform oscillation, soak, sparger, filtration & heater

40 kHz ultrasonic power with built in frequency sweep to virtually eliminate undesirable standing waves

Long warranty - 2 years immersible transducers, 5 years sonic generators

Heavy duty immersible sealed transducers

Pneumatic lift platform up to 300lbs

Automatic open/close lid

Built in weir and surface sparger

Oil skimmer

Constantly filters the cleaning solution

Double walled & insulated stainless steel tank; reduces heat loss

Low Liquid Heater Protection

Also available in 25 kHz or 68 kHz

Easy change-out drain



Fortune Metal Finishing Corp.
 116 Gould Street
 Needham Heights, MA 02494
 866.449.4160
 sales@fortunemetal.com

TUS3725SL/ TS3725SL

HEAVY DUTY SEALED TRANSDUCER



SPARGER SYSTEM



PREVENTS CONTAMINANTS FROM REDEPOSITING

BUILT IN WEIR TRAPS OIL & DEBRIS



OIL SKIMMER INCREASES SOLUTION LIFE

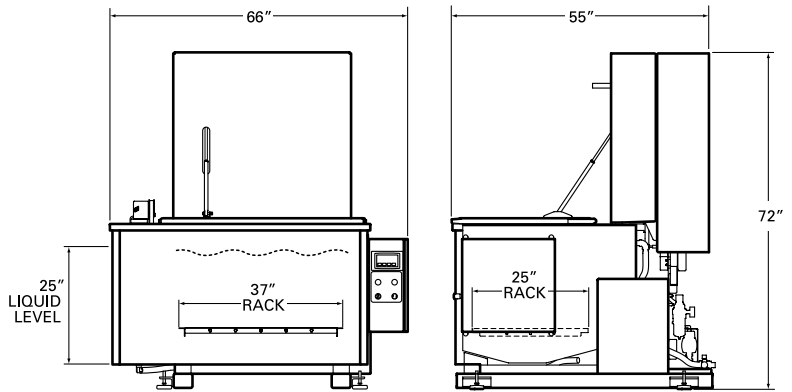

SPECIFICATIONS	TUS3725SL/TU3725SL
Ultrasonic Space	37" x 25" x 14" (max part size)
Overall Dimensions	55" x 66" x 72"
Liquid Capacity	37" x 25"
Standard Lift Capacity/PSI	300/100
Stroke Length	4"
Strokes Per Minute	25-40
Air Inlet	3/8" NPT
Drain	1 1/2"
Heater Setting Range up to 0-180°F (82°C)	6.75kW/Htr 13.5kW/Htr (optional second heater bank)
Ultrasonic Cleaning Power (TUS3725SL only)	6000W