

Pulsar 55se



Pulsar 55se blast cabinet

The ZERO Pulsar 55se is a high-production, ergonomic suction blast cabinet designed specifically to enhance productivity and efficiency by offering a safe and comfortable work station for blast operators. Repetitive work is made easier by allowing workers to concentrate on achieving the desired surface treatment, working from a seated position at their option. Cabinet design minimizes floor space requirements. Ideal for cell manufacturing environments.

Pulsar 55se Cabinet Features:

Safety

- ✓ Full-length, neoprene-on-fabric gloves resist wear and protect operator.
- ✓ Ceiling-mounted, two-tube fluorescent light fixture with abrasive-resistant Lexan® cover for extraordinary visibility.
- ✓ Safety interlocks interrupt blasting if either door is opened.
- ✓ Integrated high-efficiency reverse-pulse dust collector ensures excellent ventilation and work area cleanliness.

Productivity

- ✓ Unique air logic system maximizes air flow to the blast gun for optimum performance.
- ✓ Small footprint minimizes floor space and enhances flow in work cells.
- ✓ Ergonomic design and foot rest ease operation and reduce operator fatigue.

Convenience

- ✓ Tilt-out window, for tool-free glass changes in minutes.
- ✓ Pressure regulator, gauge, and electric switch mounted within easy reach.
- ✓ Built-in blow-off gun removes residual media from parts and cabinet interior.

Common Applications

- ✓ Cleaning parts
- ✓ Deburring machined parts
- ✓ Improving surface finish
- ✓ Removing heat scale

**Clean
Peen
Deburr
Finish**



BNP Blast Gun

The ZERO BNP blast gun sets the industry standard for performance, versatility, and durability. The ergonomic grip reduces operator fatigue and increases productivity. The standard ceramic nozzle is ideal for bead blasting, while the optional tungsten or boron carbide nozzles stand up to hundreds of hours of blasting with today's aggressive media.

Popular Accessories/Options

- Adjustable gun mount
- Alox kit (for harsh media)
- Automatic pulse kit
- Bolt-on arm rest
- Curtains (black or white)
- HEPA filter
- Magnetic screen
- Manometer kit
- Media catch trays on doors
- Noise reduction arm port covers
- Stainless steel construction
- Timed door release
- 20" dia. turntable/work tray with internal track
- Two gallon tumble basket

Authorized Distributor:



Fortune Metal Finishing Corp.
116 Gould Street
Needham Heights, MA 02494
866.449.4160
sales@fortunemetal.com

S P E C I F I C A T I O N S

COMPLETE SYSTEM

Actual space requirements depend on desired work flow. Allow additional work space for operator and maintenance.

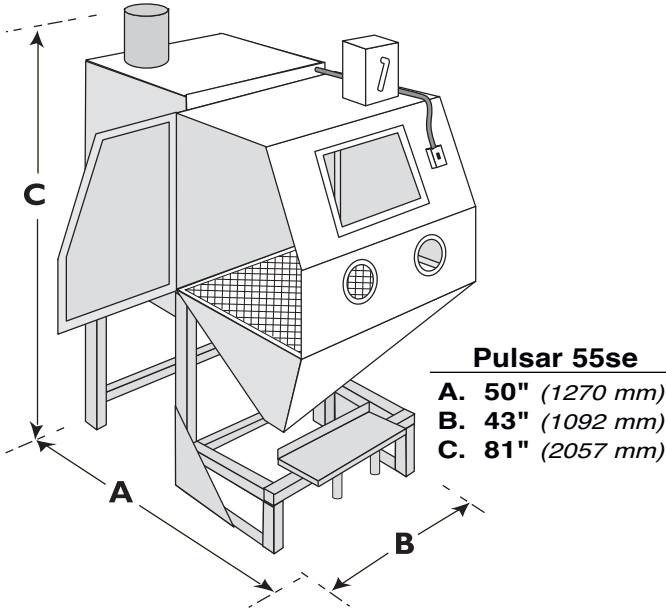

Construction; 14-gauge steel, all welded design creates a rigid, long-lasting cabinet enclosure.

CABINET

Working Chamber Size

- A. 42" wide (1067 mm)
- B. 23" deep (584 mm)
- C. 30" high (762 mm)

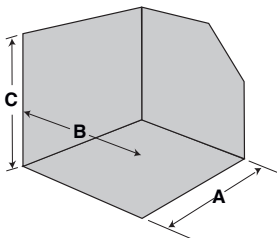

Window Size (safety glass)

- 19.5" wide (495 mm)
- 12.5" high (318 mm)

Door Opening

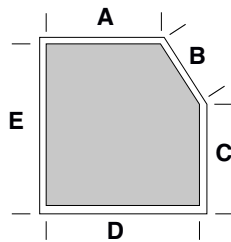

- A. 11.5" (292 mm)
- B. 18" (457 mm)
- C. 11" (279 mm)
- D. 21" (533 mm)
- E. 26.5" (673 mm)

DUST COLLECTOR

Reverse pulse cartridge dust collector (which traps 99.7% of dust down to 0.5 micron) allows non-stop, high-production blasting. The polyester-cellulose cartridge is automatically pulse cleaned for maximum filter efficiency. Worn cartridge can be replaced in minutes.

Filtering Area

195 ft² (18,1m²)

Dust concentration in exhausted air is nominally 5.0 mg/m³.

For especially dust sensitive work environments, order the optional HEPA filter.

MEDIA RECLAIMERS

Our exclusive media reclaimers continuously extract dust and debris and return properly sized, usable media to the blast system. The standard reclaimer handles all non-metallic media. Metallic media calls for special equipment considerations.

The suction blast metering valve is infinitely adjustable from fully-closed to wide open, and locks into any setting without tools.

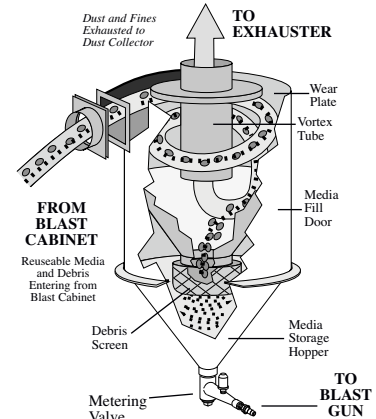

BNP BLAST GUN

AIR CONSUMPTION

BNP GUN	NOZZLE ORIFICE	AIR JET	CFM at 80 PSI	M ³ /Min at 5,5 BAR	MINIMUM RECLAIMER
No. 4	5/16"	1/8"	21	0,60	300 CFM (8,5 m ³ /m)
No. 5	5/16"	5/32"	32	0,90	300 CFM (8,5 m ³ /m)

Pulsar 55SE Cabinets come standard with a BNP gun with a No. 5 ceramic nozzle. Optional tungsten and boron carbide lined nozzles available for use with harsh media.

Reclaimer Flow Rate

Nominal 300 cfm

ELECTRICAL

1/2HP, 115V, 1PH, 60HZ Some installations may require electrical connection by a qualified electrician.

ORDERING INFORMATION

Model	Stock Number	Shipping Weight
Pulsar 55se	25921	825 lbs (375 kgs)

Distributed By:

Authorized Distributor:



Fortune Metal Finishing Corp.
116 Gould Street
Needham Heights, MA 02494
866.449.4160
sales@fortunemetal.com

ISO 9001 certified. Clemco is committed to continuous product improvement. Specifications are subject to change without notice.

© 2014 Clemco Industries Corp. • Washington, MO 63090 • 636 239-0300 • FAX 800 726-7559

Stock No.: 25731

info@clemcoindustries.com • www.clemcoindustries.com

0511 Rev. G, 10/16